

THE POLYTECHNIC SERIES

FORTY LESSONS

IN

CARPENTRY WORKSHOP  
PRACTICE

BY

CHARLES F. MITCHELL

*Lecturer on Carpentry and Joinery*

POLYTECHNIC INSTITUTE, 309, REGENT STREET, W.

AND

GEORGE A. MITCHELL

*National Silver Medallist*

POLYTECHNIC INSTITUTE, 309, REGENT STREET, W.

*NEW AND ENLARGED EDITION*

CASSELL AND COMPANY, LIMITED

LONDON, PARIS & MELBOURNE

1896

ALL RIGHTS RESERVED

THE NEW YORK  
PUBLIC LIBRARY

43130

ASTOR, LENOX AND  
TILDEN FOUNDATIONS.

CONTENTS.

	PAGE
PREFACE ... ..	3
EXTRACT FROM SCIENCE AND ART CIRCULAR...	4
LESSON 1.—Timber ... ..	7
"  2.—Fastenings ... ..	19
"  3.—Tools ... ..	25
"  4.—Cutting Tools ... ..	32
"  5.—Boring Too's ... ..	48
"  6.—Miscellaneous Tools ... ..	51
"  7.—Sawing ... ..	53
"  8.—Planing ... ..	55
"  9.—Preparing Prisms... ..	56
"  10.—Shooting an Edge ... ..	57
"  11.—Preparing Winding Strips... ..	58
"  12.—Taking Stuff out of Winding ... ..	59
"  13.—Square Edge Jointing ... ..	60
"  14.—Groove and Tongue Jointing ... ..	61
"  15.—Rebating ... ..	63
"  16.—Housing... ..	64
"  17.—Notching ... ..	65
"  18.—Cogging... ..	66
"  19.—Mortise and Tenon ... ..	67
"  20.—Double Tenon ... ..	69
"  21.—Tusk Tenon ... ..	70
"  22.—Fox-tail Wedging ... ..	71
"  23.—Dowelling ... ..	73
"  24.—Draw-boring ... ..	75
"  25.—Scarfig... ..	76
"  26.—Key Joint ... ..	77
"  27.—Lap Halving ... ..	78
"  28.—Dovetail Halving ... ..	79
"  29.—Halved Mitreing ... ..	80
"  30.—Bridle Joint ... ..	81
"  31.—Common Dovetail ... ..	82
"  32.—Lap Dovetail ... ..	83
"  33.—Diminished Dovetail ... ..	84
"  34.—Secret Dovetail ... ..	85
"  35.—Moulding ... ..	86
"  36.—Chamfering and Stop Chamfering ... ..	87
"  37.—Mitring a Frame ... ..	88
"  38.—Kerfing (Convex) ... ..	89
"  39.—Kerfing (Concave) ... ..	90
"  40.—Vencering ... ..	91
INDEX ... ..	93

## PREFACE.

---

THESE lessons have been drawn up for students who are intending to follow either the Course of Manual Training in Woodwork, as indicated in the instructions of the Science and Art Department, or that as specified by the City and Guilds of London Institute: to teach the use of tools employed in the handicrafts using wood, and to serve as a disciplinary educational course in training the hand and eye to accuracy, by a progressive series of exercises connected with Freehand and Drawing to Scale, and thus tend to produce thoughtful and efficient workmen.

Great care has been exercised in the choice of such dimensions of stuff as will avoid unnecessary waste, and yet not endanger the utility of the lessons, which are graduated in the order of difficulty, being the result of considerable and successful experience in this branch of education.

The success of the First Edition and the suggestions on Manual Instruction issued by the Department have resulted in a complete revision.

I hope this treatise may be found necessary, useful, and valuable in the training of all apprentices, youths, and artisans in the elements of the wood-working trades, the chapters on tools claiming special attention, as may be suggested by the results of the instruction given to Polytechnic students, who have during the past seven years been awarded eighteen gold, silver, and bronze medals by the examiners of the Worshipful Company of Carpenters, and the City and Guilds of London Institute.

CHARLES F. MITCHELL,  
HEAD MASTER.

## SUGGESTIONS FOR MANUAL INSTRUCTION.

---

THE following observations must be regarded more in the light of suggestions than rules to be rigidly followed.

Before commencing to work with tools it will be found very useful to practise the younger children in cutting out and putting together solid models in cardboard or paper from plane projections (known technically as "nets"). All work with tools must, as stated in the Minute, be from careful full-size or large scale drawings prepared by the scholar. These drawings should, if not prepared in the workshop, at any rate be executed under the direction of the Manual Instructor, and they should, as far as possible, serve as working drawings for the practical exercises.

The tools required for the early stages of manual instruction in carpentry are the saw, the plane, and the chisel. The construction and mode of use of these tools, and demonstrations illustrating the proper methods of sharpening them and of keeping them in good working order should form the subjects for preliminary lessons.

Clear ideas respecting the various kinds of hard and soft woods, the growth and structure of wood, its fibre, and grain, and the uses of the different varieties of timber, may be given by means of a small collection of the chief descriptions of timber commonly employed in carpentry, with longitudinal and cross sections.

A great variety of exercises may be arranged, suited to the strength and ability of the scholar, in the use

of these tools which will give an elementary knowledge of the principles of construction, and at the same time teach accuracy and carefulness.

*The plan of instruction known as the Slöjd System, though it possesses many excellent features, does not in its earlier stages comply with the requirements of the Department, in that the exercises do not involve the use of the common tools employed in handicrafts, and work done at the school desk with a clasp-knife cannot be accepted as manual instruction in respect of which grants can be paid by the Department of Science and Art.*

The earlier exercises should include some such as the following:—Sawing off across the grain of the wood, and sawing along the grain of the wood, blocks and strips of given dimensions taken from a drawing prepared by the boy himself, and having marked on it the required dimensions. Many varieties of tenon and of halved joints can be made in the rough by the saw alone.

The use of the plane can be commenced by planing small surfaces up to three inches in width and one foot or upwards in length, and then planing down strips to a given thickness. The planing of two surfaces at right angles to each other, the preparation of a right square prism and of a hexagonal prism, and the construction of a straight-edge with bevelled edges should follow later.

The joints used by carpenters form a valuable series of exercises in which the use of the saw and chisel may be learnt; such as the various forms of halving, of mortise and tenon, notching, dowelling, dovetailing, groove-and-tongueing, and scarfing with keys or wedges. The teacher should draw up a complete series of simple and graduated exercises for the early stages which all members of the class should execute in turn. No attempts should be made at first to construct small articles of furniture. Neatness of workmanship and a due regard to finish should be insisted upon in all cases.

The proper use of nails and screws should be explained and practised till a fair measure of accuracy has been attained.

So far the instruction does not involve the use of curved surfaces. If the workshop is provided with a lathe, another graduated series of exercises might be arranged for more advanced students, to include the simpler forms of turning, but this is not insisted on.

There should be not less than four feet run of bench for each boy under instruction, and he should have a space of at least two feet in width in front of the bench. The room should be well lighted and ventilated. There should be a bench and set of tools for the use of each scholar when under instruction, with a proper place in which to keep them, each bench being provided with a wood or metal vice as the case may be. A teacher cannot properly direct the manual instruction of more than about twenty boys at one time.

# FORTY LESSONS IN CARPENTRY WORKSHOP PRACTICE.

## LESSON I.—TIMBER.

BOTANISTS classify plants under two heads, the Phanerogams and Cryptogams, the flowering and the non-flowering plants.

The trees from which timber for use in construction and for furniture, etc., is obtained, are of the former

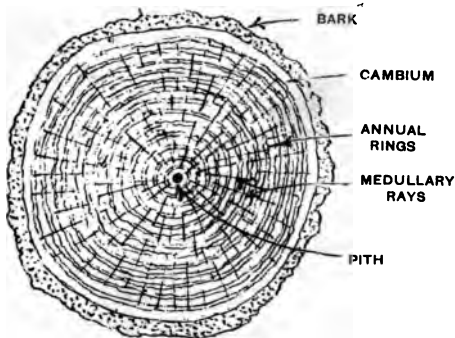

FIG. I.

division. The Phanerogams are subdivided into two classes: the exogens or outward growers, and the endogens or inward growers.

The exogens comprise those trees which increase in bulk by successive accretions in concentric layers of the substance of which the tree is formed on the outside of the pith, or of the preceding layers, and directly beneath the bark or skin.

If a transverse section be taken through the stem of

a typical exogen such as the oak, as shown in Fig. 1, upon examination the following parts will be seen :—

1. Pith.
2. Annual Rings.
3. Medullary Rays.
4. Cambium.
5. Bark.

*Pith.*—The pith, which is the first formed portion of the tree, consists of cellular tissue, and in the young plant the functions of vegetation are carried on through it ; but after a few years, the circulation of the sap takes place through the annual rings which have been deposited, the pith then ceasing to perform any active part in the life of the tree, and in course of time decays.

*Annual Rings.*—The annual rings consist of cellular tissue and woody fibre deposited in concentric cylinders about the pith. The term annual is applied to them, because, in temperate climates, one layer is deposited yearly ; but in the tropics, where the seasons are not so distinctly marked, there may be more than one layer per annum.

The annual rings consist of two parts—the spring and the autumn wood. These portions are respectively formed during the rising and descending of the sap by the activity of the cambium cells, these latter consisting of a layer of generative tissue immediately adjacent to the bark, and having the characteristic property of dividing and multiplying under the action of heat and moisture, forming the annual rings and also the new material for the bark. The cells formed during the autumn are smaller in section and more compact than those formed during the spring, and accordingly are easily observable in the wood, their greater density causing them to appear darker than in the spring wood.

*Medullary Rays.*—These are thin bands of cellular tissue extending in a horizontal direction and showing as lines in a cross section of the tree, and radiating from the pith interposed between the woody fibres.



Their function is to act as a duct to allow of the transmission of moisture and sap to the interior of the tree.

*Bark.*—The bark is the outer covering of trees, formed of woody fibres. As spring time approaches the ascending sap causes the bark to become loose, and the latter, being slightly elastic, stretches under the centrifugal action of the newly formed zone. As the tree increases in age the continuous addition of annual layers causes the outer layers of the bark to split and portions to break away and fall.

*Felling.*—Trees should not be felled before they have reached maturity, a period the experienced forester can determine from the appearance of the foliage, the size and other indications peculiar to different woods and varying conditions.

If the tree is felled before it has matured, the timber will not be durable; if felled very much after, it will be brittle and inelastic. The proper season for felling the tree is mid-winter, because at that time vegetation is practically at a standstill, and the newly formed cells are in a better condition to resist decomposition than at any previous stage in their formation; if felled while the cambium is active, and the sap is circulating, the partly formed cells rapidly decompose, and are liable to induce decay in the otherwise sound portions of the tree. There is also much less moisture in the tree at mid-winter than at any other period of the year.

*Conversion.*—Immediately the tree has been felled, the log should be trimmed of its branches, barked, and sawn to dimensions suitable for the final purposes for which the wood is intended.

The timber is cut lengthwise in a direction either:—1st, tangentially to, or as a chord of, the annual rings; or, 2nd, radially. The first method is employed in highly figured timbers, to obtain the effect of the obliquely cut annual rings, also in soft woods to obtain the maximum quantity of timber of rectangular section;

the second method is adopted to obtain the effect of the medullary rays, and is extensively applied to oak.

*Seasoning.*—After the wood is converted, it is stacked to season, the object of which is to dry the free moisture out of the timber. There are two methods in common practice for accomplishing this. The first, known as natural seasoning ; the second, the desiccating process. The first method consists in stacking the stuff in the open and preventing any damage from the effects of the sun or the rain by covering the top with a roof, or, preferably, stacking in a shed which is open at the sides.

Secondly, the principle of the desiccating process is to stack the stuff in a heated chamber to accelerate the drying out of the moisture ; it is more applicable to small scantlings, and is usually adopted in large firms to work that has been partially prepared. The stuff, having been first seasoned naturally and sawn to scantling and planed, is placed in heated chambers to dry out any excess of moisture it may still contain.

With both methods great care should be exercised to stack the unseasoned stuff perfectly true and out of winding ; and that arrangement is to be preferred which allows a current of air to pass over the greatest area of the surface of the stuff.

*Selection.*—In selecting timber, the following points should be noted. The timber should be of a bright appearance, dulness in almost all examples betokening decay.

In sawing, the timber should cut short, and not clog the teeth of the saw ; and in planing it should finish with a silky lustre. The timber should have its characteristic odour, any deviation from this generally denoting decay. There should not be an excess of sap-wood, as this must on no account be used. The stuff should be free from shakes, of which there are three well-known varieties—viz. heart shake, star shake, and cup shake. The first originates at the pith, and

radiates in a number of clefts from the centre ; this is generally due to the decay and drying of the central portion of the tree. The second is star shake. The clefts in this case commence at the outside radiating inwards, and may be the result of decay and the drying of the outer portion of the tree, or to unequal or violent expansion and contraction due to sudden changes of temperature, and the freezing of the moisture in the outer portion of the tree.

The third is cup shake, which consists of the separation of the annual rings from each other. Where this occurs near the exterior, it may be due to the expansion of the outer layers during hard frosts, and, if occurring near the centre, to the shearing stress set up in the tree in bending when the latter is subjected to high winds or to violent gusts. The other kinds of shakes, and combinations of the three above-mentioned, may be due to the destructive agency of the wind, as they are found to be very prevalent in trees grown in exposed positions.

Wandering heart and twisted fibres are defects most probably due to a prevalent wind, which has caused the tree to tend to turn constantly in one direction ; such timber is practically useless for constructional purposes, as so many of the fibres are cut during conversion. The timber should be uniform in colour, any sudden changes of colour other than the difference between the heart and sap-wood, such as white or red patches or spots, being usually attributed to some form of decay. The annual rings should be close and uniform ; timbers in which the rings are large, or not uniform, are usually weak.

*Shrinkage of Timber.*—The medullary rays may be considered as thin, hard, vertical plates of cellular tissue, and in harder woods especially, practically unyielding and unshrinkable. The seasoned section of a piece of timber may be determined by imagining these plates to act as ribs of a system (such as a fan) and closing upon its centre.

*Decay in Timber.*—Decay usually commences with the decomposition of the albuminous substances contained in the timber. The two forms of decay most generally known are the dry rot and the wet rot. The former is a chemical decomposition caused by an external living agent in an imperfectly ventilated atmosphere; while the latter is a chemical decomposition of the sap and fibre of unseasoned wood, or, if seasoned, results from exposure to the moisture of a temperate atmosphere.

*Dry Rot* is caused by the growth of fungi, the spores of which, floating about in the atmosphere, alight on timber when under favourable conditions, and these, germinating, insert their roots into the timber, the constituents of which they decompose, and so obtain their nutriment. These plants rapidly spread over the whole of the timber, and attack other timbers in the vicinity, causing them to crumble. The conditions favourable for dry rot are a warm, humid atmosphere, insufficient ventilation, and the presence of any green sap in the timber. All stuff in constructional works should therefore be thoroughly seasoned before being used, and well ventilated when fixed.

*Wet Rot* is caused by the oxidation of lignin and other substances in the presence of air and water, the oxygen combining with the carbon to form  $\text{CO}_2$ , and with the hydrogen to form  $\text{H}_2\text{O}$ . The hydrogen, however, becomes more rapidly oxidised than the carbon; consequently, the latter remains in excess, and a brown snuff-coloured powder results, which contains a larger proportion of carbon than the woody fibre.

Moisture is necessary to the process, which takes place in the open air,  $60^\circ$  Fahr. being the most favourable temperature.

In trees which have passed their maturity the decay usually commences with the pith, hence the necessity of cutting through and thoroughly examining the heart of large timbers.

The timbers in use for constructional and general work are classified under two heads—1st, soft woods from the needle-leaved or cone-bearing trees; 2nd, hard woods from the broad-leaved trees.

The first section includes the pines and spruce as follows:—

*Northern Pine* (*Pinus sylvestris*).—This timber is obtained largely from the following ports: Memel, Dantzic, and Stettin in Prussia; St. Petersburg, Riga, Onega, Archangel, and Narva in Russia; Christiania and Dram in Norway; Gefle and Soderham in Sweden. It is also extensively grown in Great Britain, being known here as Scotch fir. It is of a light yellow colour; the annual rings are clearly defined, consisting of a light and a dark portion; they are regular and about  $\frac{3}{16}$  inch in thickness; medullary rays not visible; straight grained; weighs about 36 pounds per cubic foot; contains resinous substances which render it durable; it is strong and elastic; does not warp nor shake to any extent; is easy to work, and cuts clean and short. This wood is largely used for constructional work and for joinery, being suitable both for internal and external work.

*American Yellow or White Pine* (*Pinus strobus*).—This timber is exported from Quebec, St. John's and Shedac, and a few other Canadian ports. It is sometimes known as Weymouth pine. It is of a whitish or pale yellow colour, annual rings not very distinct; they are regular and about  $\frac{1}{4}$  inch in thickness; medullary rays not visible; it is very straight grained; weighs about 29 pounds per cubic foot; is not as strong nor elastic as northern pine; does not warp much, but is liable to shake; is very easy to work, and is used chiefly in joinery work for mouldings and wide panels; it does not prove durable when used externally.

*Pitch Pine* (*Pinus rigida*).—This timber grows in the south-eastern States of North America, and is shipped chiefly from the ports of Savannah and Pensacola. It is of a dark yellow or light reddish-brown

tint; annual rings clearly defined and of a uniform width of about  $\frac{3}{16}$  inch; medullary rays not visible; it is straight grained, and can be obtained in great lengths; is highly charged with resinous substances, rendering it very durable; weighs about 46 pounds per cubic foot; it is very strong and, compared with other pines, difficult to work; has a tendency to stick to the tools on account of its large quantity of resin. It is subject to heart and cup shake, shrinks considerably in drying, and also tends to warp.

The straightness of grain, great strength, and large scantling render it valuable for constructional work; and it is largely used for ornamental joinery work on account of the beautiful figure of its grain, although its excessive shrinkage renders it unsuitable for this purpose.

*White Fir or Spruce* (*Abies excelsa*).—This wood is obtained chiefly from the following ports: Onega, Narva, and St. Petersburg in Russia; Christiania, Dram, and Frederikstadt in Norway; and Gottenburg, Sandsvall, and Hernosand in Sweden. It is of a whitish or very pale yellow colour; annual rings clearly defined, uniform, and about  $\frac{3}{16}$  inch in thickness; medullary rays not visible. The wood is usually straight grained, weighs about 32 pounds per cubic foot, contains resinous substances, but not to the same extent as northern pine. It is strong and elastic; it warps and splits in drying; is tough but easy to work when free from knots, which in this wood are very hard; it cuts clean and free with the saw, and finishes with a silky lustre from the plane, and is sufficiently close grained to take a polish. The best kinds of this wood are used largely for internal joinery work; it is not durable when used externally; the coarser varieties are used for packing-cases, and for similar rough purposes. It has a beautiful figure, and is often varnished in order to obtain the effect of the same. It is much used for constructional work, but is neither as strong nor as durable as northern pine.

The second section includes oak, mahogany, etc.

*Oak* (*Quercus*).—This timber abounds in Europe (including Great Britain), Asia, and America. There are a great many species of oak, but all have the same general characteristics, differing only in minor details.

There are two kinds native to this country, viz. *Q. pedunculata* and *Q. sessiliflora*; the chief difference between the two lies in the arrangement of the flowers and leaves.

The former is generally supposed to be the more durable; the latter is credited with being tougher and more difficult to rend, and can be obtained in greater lengths, and is straighter grained than the *pedunculata*; it is light brown in colour; annual rings distinct and generally fairly uniform, about  $\frac{1}{8}$  inch in thickness; medullary rays strongly marked; grain fairly straight, but in trees grown in the open usually gnarled and twisted; weighs about 48 pounds per cubic foot. It contains gallic acid, which rapidly corrodes ironwork, thus preventing the general employment of these two materials together; it is subject to warping and shaking; is very tough and difficult to work, but will take a high finish. It is greatly prized for ornamental joinery work on account of its figure and the beautiful markings of the medullary rays when the log is cut lengthwise radially; it is very durable and strong, and therefore valuable for heavy constructional work; it is very durable in either a wet or a dry situation, and proves more durable than most other woods in an alternately wet and dry position.

*Mahogany* (*Swietenia mahagoni*).—Mahogany is obtained from the West Indies and Central America, the chief supplies coming from Cuba and Honduras. Mahogany is of a reddish-brown colour; annual rings not very distinct but uniform; medullary rays invisible; fairly straight grained, weight (Cuba) about 53 pounds per cubic foot, (Honduras) about 35 pounds per cubic foot. It is strong, but inclined to be brittle; it warps, shrinks,

and shakes very little ; it is hard, not very difficult to work, and is capable of receiving a high finish and a splendid polish.

The wood lasts well when used internally, but is not durable when employed for external purposes ; it is chiefly used for cabinet work and ornamental joinery, for shop fittings and internal finishings. Cuba or Spanish mahogany, as it is sometimes called, is darker and richer in colour than the Honduras, and has a more wavy grain than the latter, which produces when cut a beautiful figure ; this renders it very durable for the highest classes of joinery work. It is harder and denser, but does not attain such large dimensions as the Honduras. The Cuba may be easily distinguished from the Honduras by a chalk-like substance filling its pores. The Honduras is chiefly noted for the straightness of its grain, rendering it particularly adaptable for sticking mouldings. It is used for all kinds of internal joinery and cabinet work ; is largely used for pattern-making on account of the small amount of its shrinkage ; it is sometimes known as bay-mahogany or bay-wood.

*Elm* (*Ulmus*).—This timber is grown in large quantities in England. It is of a brown colour ; annual rings distinct ; medullary rays invisible to the eye ; has a very twisted grain ; weighs 37 pounds per cubic foot ; it is very liable to warp and shake ; is very tough and difficult to work ; it is very durable when kept either thoroughly wet or perfectly dry. It is used chiefly for the sides and bottoms of carts, the hubs of wheels, for coffins, wood pulley-blocks, and for all similar purposes requiring a tough, strong wood.

*Ash* (*Fraxinus*).—This timber is obtained in large quantities in Great Britain. It is of a light brown colour ; annual rings distinct ; medullary rays not visible ; is straight grained ; weighs 52 pounds per cubic foot, and is very tough, strong, and elastic ; is subject to shake in seasoning ; durable if properly seasoned ; has a large proportion of sap-wood. Its great elasticity



debars its use for all large structural operations, but it is valuable as shafts for hammers, spokes for wheels, for oars, and in any position where it will be subject to sudden stresses.

*Beech* (*Fagus*).—Large quantities of beech are obtained in England. It is of a light reddish-brown colour; annual rings distinct; medullary rays strongly marked; can be obtained in great lengths and is very straight grained; weighs 43 pounds per cubic foot; is strong, tough, and durable if kept dry; is close grained and easy to work, and will take a high finish. It is largely used for furniture, and owing to its close and even grain is valuable for tools which require an even wearing surface.

*Sycamore* (*Acer Pseudo-Platanus*).—This timber abounds in England. This wood is sometimes known as the common or great maple. It is brownish- or yellowish-white in colour; annual rings distinct; medullary rays small but distinct, often has a beautiful figure; fairly strong, fairly difficult to work; weighs about 38 pounds per cubic foot, is durable when kept dry. It is used chiefly for furniture and ornamental joinery.

*Basswood* (*Tilia americana*).—This wood is obtained from the United States and Canada. It is of a yellowish-white colour; annual rings indistinct; medullary rays invisible; is straight grained and of a uniform substance, soft and easy to work, and is of a very uniform grain and may be cut easily across or in any direction of the grain. It is largely used for cabinet work and also for carving.

*Lime* (*Tilia europæa*).—Obtained plentifully in England. It is of a whitish colour; annual rings distinct; medullary rays invisible; very straight grained and uniform in density, very soft and easy to work in any direction. It is largely used for cabinet work and for fine carvings.

*Cedar* (*Abies Cedrus*).—From Asia and America. Is of a reddish-brown colour, porous, soft, and of light

weight ; has a pleasant odour, which is, however, obnoxious to insects and vermin, and is therefore suitable for furniture. It works easily, shrinks little, and is used for patterns, carved toys, pencils, and boat-building.

*Larch* (Genus *Larix*).—From Europe and America. Of honey-yellow or brownish-white colour, the toughest and most lasting of the coniferous order ; has straight grain and is free from knots, but is very liable to warp, shrinks very much, and is extensively used for posts and railway sleepers.

*Kawrie Pine* (*Dammara australis*).—From New Zealand. Of yellowish-white colour, and possessing a silky, straight grain ; is generally free from defects, light, strong and elastic, and is good for joinery.

me  
oak

oak  
hickory

beech

boxwood

rosewood

walnut  
e

ebony

elm

ash

chestnut

## LESSON II.—FASTENINGS.

The following fastenings are commonly used by the wood worker:—Glue, wedges, keys, buttons, angle-blocks, dowels, trenails, brads, nails, spikes, screws, bolts, nuts and washers, dogs, iron straps, and sockets.

*Glue.*—This is procured from the horns, hoofs, hides, and other parts of animals by steeping, washing, boiling, straining, melting, reboiling, and casting into cakes.

There are two varieties in general use—the Scotch and the French; the former is very adhesive, but



FIG. 2.

presents a black appearance; the latter is not quite as effective, but is lighter in colour.

The vessels for heating glue consist of an inner and an outer pot, as shown in Fig. 2, the former fitting into the latter, and being brought into contact at their upper rim only. The outer pot, which is brought into contact

with the gas jet or fire, is partly filled with water; the inner pot, which contains the glue to be melted, when in position is partly immersed in the water in the outer pot; this water when boiling supplies the necessary heat to dissolve the glue. This arrangement is adopted, as it is imperative that the glue should be dissolved by a wet heat.

It is important to note that glue deteriorates if exposed for a long time to a great heat, or if it be reheated many times. More should not therefore be made than is required for one or two days' use; and it should be softened by being well soaked in cold water before being heated, to reduce the time required to accomplish that operation.

The method of preparing glue is as follows:—The cakes are broken into small pieces and placed in a pail containing cold water, where they remain for about a day to soften; they are then placed in the inner pot, and sufficient water is added to cover the same; the glue-pot is then placed upon the heating apparatus and boiled gently for about two hours, during which time it should be frequently stirred to ensure uniformity; at the end of this time it will be ready for use. Glue should be applied while hot, but must not be burnt. For joint-making, glue should be strained by running it while hot and fluid through a coarse canvas, which serves to retain any dirt or foreign matter.

*Wedges* are pieces of wood cut with two length faces parallel and with two faces inclined to and intersecting each other, but at right angles to the former pair. These are extensively used in woodwork to secure tenons in mortises and to fix parts together.

*Keys* is the name given to wedges (as shown in Fig. 89), generally of hard wood, used to pull parts together that may be required to be taken to pieces afterwards.

*Buttons* are small pieces of wood, tongued at one end, and fixed by a screw to a wide panel. The tongue

of the button enters a groove in, or clips a batten at, right angles to the wide panel, the effect being to keep the panel secure to the batten, and yet leave the former free to expand or contract in one plane. This method is often employed for securing wide surfaces of wood, such as table tops or drawing-boards, to framing or battens.

*Angle-blocks.*—Pieces of wood, triangular in section, generally of dry American yellow pine, with two length faces at right angles to each other; they are often used to secure two adjacent parts together, such as the riser and step of a stair, by saturating the length faces at right angles to each other with glue and well rubbing the glue-covered surfaces of the angle-block against the adjacent faces of the two pieces required to be kept together.

*Dowels* are small hard wood pins circular or polyhedral in section. When being prepared, to ensure continuity in the fibres, they must be rent and trimmed with a chisel, and not cut with a saw. Where desired to be circular in section they are first trimmed approximately so with the chisel, after which they are driven through a hole in an iron plate, the latter being provided with a number of holes of the exact size of the joiner's twist bits. Dowel pins are used for securing mortise and tenon joints (as shown in Fig. 96), and to keep boards that form wide surfaces in the same plane (as shown in Fig. 94).

*Trenails*—Hard wood pins of large diameter are called trenails and are extensively used in carpentry, or in positions where iron fastenings would be liable to rust.

*Nails.*—Nails are pieces of metal plate or wire, tapering or prismatical, with points, all of which are cast, cut, or stamped with heads. They may be obtained in cast-iron, wrought-iron, steel, zinc, copper, brass, or in composition metal. The greater number have one pair of sides parallel in length, which should always be driven in with those sides parallel to the length grain, to reduce

the tendency of the nail to split the wood in its progress through the same after each blow. Hard woods are bored to receive the nails; but in the softer woods this is not always necessary. There is a great variety of nails; those in common use being manufactured from wrought-iron or steel.

*Cast-iron Nails.*—These have been used for slating purposes, but are very brittle and are now discarded.

*Wrought-iron Nails.*—Cut clasps are cut by machinery from wrought-iron plates, to the form shown

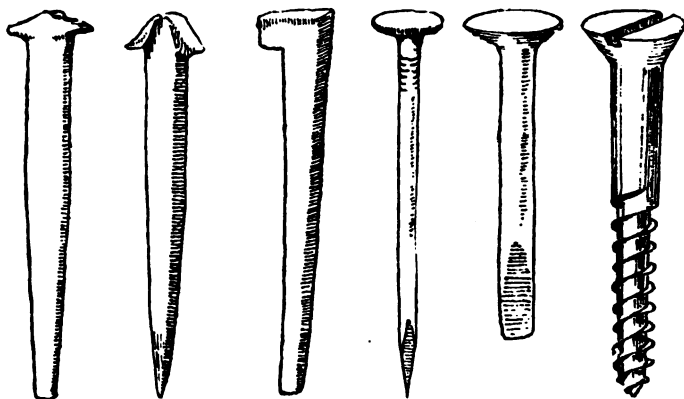

FIG. 3.

FIG. 4.

FIG. 5.

FIG. 6.

FIG. 7.

FIG. 8.

in Fig. 3, and are the nails most commonly used. Clasp nails 4 inches and above in length are known as spikes. Nails cut from plates of wrought-iron by manual labour, of the form shown in Fig. 4, are particularly known as wrought nails, and possess the property of bending sufficiently to clinch without breaking. Of late years, however, these have been produced by machinery, which has been improved to cut sufficiently and yet not to destroy the tenacity and pliability of good wrought-iron.

*Brads.*—Tapering nails of parallel thickness with

heads projecting only on one side, as shown in Fig. 5, are used to connect parts together where the nail hole is required to be of the minimum size.

*Needle Points* are small steel pins, circular in section, similar to the ordinary needle, but without eyes. These are used to fix hard wood moulding to joiners' work, and also in the process of veneering.

*Clout Nails.*—These are nails with shanks rectangular or circular in section, with large, flat, circular heads, as shown in Fig. 7. Small clout-headed nails are called tacks. Zinc, copper, and composition nails of this type are largely used to secure slating, as these resist oxidation better than the iron.

*Wire Nails.*—These are usually circular, elliptical, or rectangular in section, and are usually known as French nails. They are very tough and strong, and do not break so readily as the clasp, but whilst being driven in position are apt to split the wood. Those circular in section (as shown in Fig. 6) are often used in packing-case making, and the elliptical, with small heads, for securing mouldings to joiners' work.

*Screws.*—Fig. 8 shows the form of screw used for fixing woodwork. They are usually made of wrought-iron or of brass, the latter resisting oxidation better than the former metal. They are made with one end tapering to a point to permit of the screw entering more easily, the thread being of a coarse pitch. The shape of the head generally determines the name, such as round-headed, countersunk-headed, etc.

*Bolts* are large screws with square or hexagonal heads, and are extensively used for carpentry work. Large timbers are often held together with bolts, which are passed through holes bored in the timbers and secured by nuts, which are square or hexagonal pieces of wrought-iron similar to the heads, but drilled and tapped to receive the shank of the bolt. The thread on these bolts and nuts is finer and of a less pitch than on the screws for wood.

*Dogs* are pieces of flat or round wrought-iron, bent at ends and pointed (as shown in Fig. 9). They are used in temporary carpentry work to secure large timbers which rest on or abut against each other, the

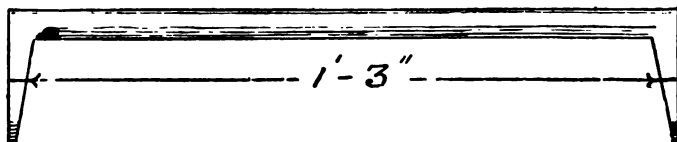

FIG. 9.

pointed ends being driven one in each of the adjacent timbers.

*Iron Straps and Sockets* are used to secure joints in wooden roofs and partitions, being forged or cast to the required shape.

*Galvanising*.—Iron nails and screws that are to be used in exposed positions are sometimes galvanised—that is, coated with a thin layer of zinc to prevent oxidation.



## LESSON III.—TOOLS.

The workshop should be furnished with the following tools, and the student should learn their names and be made acquainted with their use:—

### SETTING-OUT TOOLS.

Two-fold 2-foot Rule.	Chalk Line.
6-inch Try Square.	Pair of Compasses.
Bevel with Steel Blade.	Mortise Gauge.
Straight-edge.	Marking Gauge.
Plummet and Rule.	Setting-out Knife.
Spirit Level.	Pair of Winding Strips.

### CUTTING TOOLS.

Trying Plane, 22 inches long.	Bow Saw.
Jack Plane, 18 inches long.	Ten Firmer Chisels, $\frac{1}{8}$ inch to $1\frac{1}{2}$ inch.
Smoothing Plane.	Five Mortise Chisels, $\frac{1}{4}$ inch to $\frac{1}{2}$ inch.
Six Hollows.	Two Gouges, Small and Medium.
Six Rounds.	Slow-cutting Oil Stone.
$\frac{3}{4}$ -inch Rebate Plane.	Arkansas Stone Slip for Sharpening hollows.
Plough and set of 8 irons, $\frac{1}{8}$ inch to $\frac{5}{8}$ inch.	Oil Can and Salad Oil.
Half Rip Saw, 3 teeth to inch.	Cutting Gauge.
Hand Saw, 4 " "	Spokeshave (Small).
Tenon Saw, 8 " "	Router.
Dovetail Saw, 15 " "	

### BORING TOOLS.

Brace and Set of assorted Bits.	Three Bradawls.
Three Gimlets.	

### MISCELLANEOUS TOOLS.

Bench.	Two Screw-drivers, Small and
24-inch Grindstone, mounted in Trough.	Two Punches. [Medium.
Glue Pot, Glue, and Glue Brush.	Pair of Pincers.
Joiner's Cramp, wrought-iron.	Mallet.
Small and Large Hammers.	Two Sawing Stools.
	Two Hand Screws.

*Classification.*—The tools employed for the working of timber may be broadly divided into two classes:—

First, those required for setting-out and testing the accuracy of work; secondly, cutting tools. The chief among the former are—the rule, the try and the set squares, the bevels, the compasses, the straight-edge, the plummet and rule, the spirit level, the chalk line, winding strips and gauges; thirdly, boring tools; and fourthly, miscellaneous tools.

*Setting-out Tools.*—The rule is employed for measuring up work or setting down dimensions. It consists usually of a thin strip of boxwood, 2 feet in length, divided into inches, eighths, and sixteenths, and in order to make it easily portable it is made to fold by means of hinged joints into a half (as shown in Fig. 13), or a fourth of its total length. If great lengths or large areas have to be measured rules 5 feet or 10 feet in length are employed, or metallic tapes, which are commonly made up to about 60 feet in length.

The try square (as shown in Fig. 10) is used when shooting the edge of a board to test whether the same is square with a given surface, and also to set off lines on any surface at right angles to a given edge. It is composed of a steel blade (having two parallel edges) fixed at right angles to the edge of a wood stock, the latter having its square edge faced with brass to render it more durable. These are made with their blades from 2 inches to 1 foot in length; beyond the latter dimension the whole of the square is usually made of some hard wood.

Set squares and bevels are employed to test if the angle between the two surfaces (which are to be fixed either square or at any other angle with each other) is correct during and after the process of fixing. They are also used in setting-out work requiring lines at right or oblique angles. If of sheet zinc, they are usually made up to about 9 inches length of edge; when required larger they are of wood.

*Bevels.*—Edges of boards required to be planed to any required angle with the face are tested for accuracy by the bevel. This is formed of a steel blade with parallel edges and having a slot extending from the centre to within a short distance of one extremity of the blade, which is connected to a wood stock (which has a cut down the centre equal to the thickness of the blade) the latter being placed in the cut in the stock and a screw passed through the stock and the slot in the blade (as shown in Fig. 11). The screw may be slackened or tightened, thus allowing of the blade being set at any angle. The slot in the blade enables the operator to fix the whole of the latter on one side of the stock. Bevels of large dimensions are made in wood.

*Compasses.*—These are employed for transferring distances and for scribing, *i.e.* drawing a line on any surface parallel to a given line on an irregular surface. There are two kinds, both entirely constructed of steel. In the first (as shown in Fig. 12) there is a thin member in the form of a quadrant attached to one leg and passing through a mortise in the second. The compasses when opened may be secured at any angle by a screw passing through the second leg and biting tightly against the side of the quadrant. In the second kind both legs are out of one piece of steel, the central portion being formed as a spring, which is so set that the natural tendency of the legs is to fly apart. The legs are kept together by a screw fixed to one leg and passing loosely through a hole drilled in the other, the distance being regulated by a fly-nut placed on the screw on the outside of the second leg. These, for general work, are inferior to the former kind, for, not being rigidly fixed, they are, while in use, likely to become altered.

*Straight-edge.*—The straight-edge (as shown in Fig. 14) is used for testing the accuracy of the work when forming plane surfaces or straight edges; it is also largely used in setting-out work. It is usually of

American white pine, being made of all dimensions, those most convenient varying from 4 to 7 feet in length, 4 to 6 inches in width, and from  $\frac{3}{4}$  inch to 1 inch in thickness. They require testing at frequent intervals to ensure accuracy.

*The Plummet and Rule.*—These (as shown in Fig. 15) are necessary when it is required to fix any member or piece of work vertically. The plummet consists of a piece of lead, oval in form, with a hole passing through its longest axis through which a line passes. The ordinary plummet weighs about 4 pounds, but heavier ones are to be preferred.

Where it is required to determine the position of one or a series of points perpendicularly above or below a given point, the plummet is often employed independently of the rule.

The plumb rule usually consists of a piece of straight grained white pine about 5 feet long and 4 inches wide, the sides being perfectly parallel and straight; a gauge line is marked along the middle of one face parallel with the sides; a saw cut is made about  $\frac{1}{2}$  inch in length down the gauge line in the upper end of the rule in which the twine connected with the plummet is inserted; a hole of a shape similar to that of the plummet, but much larger, is made in the rule about 6 inches from the bottom end, symmetrically about the gauge line. The plumb-line is inserted in the cut mentioned and the plummet hangs freely in the hole. In fixing work, the plumb rule is placed against the face, and the whole adjusted until the plumb line exactly coincides with the gauge line on the rule; this done, the work is secured. In fixing work in which the faces are not perfectly upright (such as in a tapering column or one with an entasis) the sides of the rule have to be shot to make the required angle with the centre line of the rule, or shaped to fit the face of the work to be fixed.

*The Spirit Level.*—This (as shown in Fig. 16) is employed to adjust work requiring to be fixed perfectly

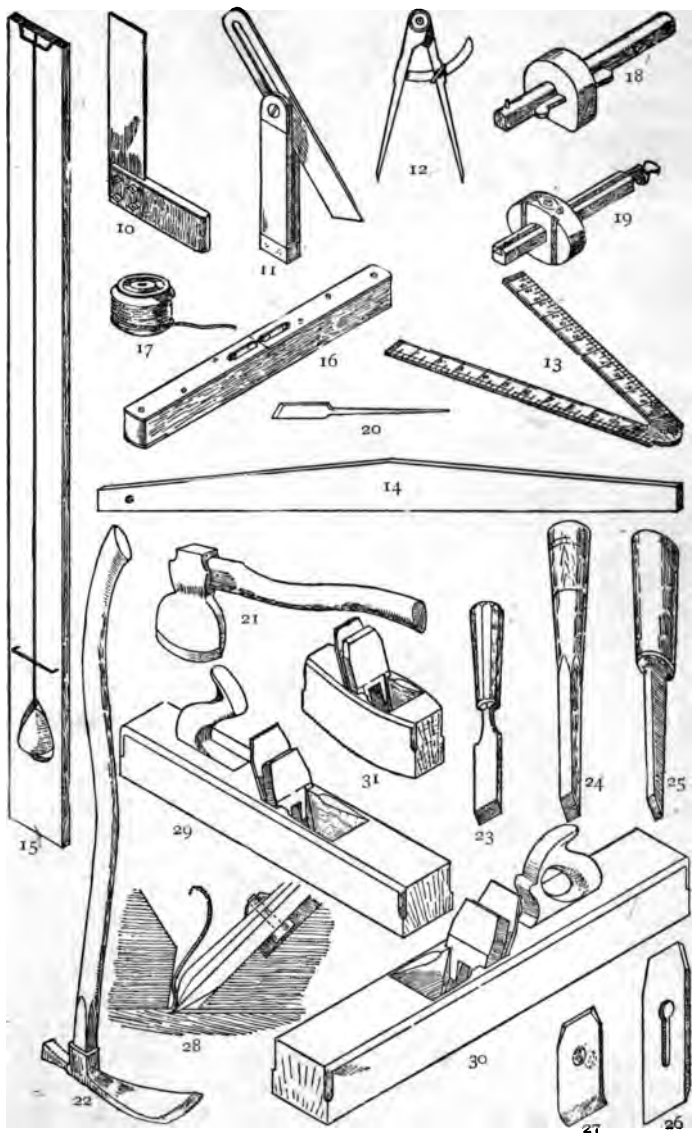

FIGS. 10 TO 31.

horizontal. It consists of a wood stock ; the under edge (which has to be applied to the work) must be shot perfectly straight ; a mortise is sunk in the upper edge for the reception of a glass bulb containing spirits of wine. For ordinary purposes this bulb consists of a tube about 4 inches in length and about  $\frac{3}{8}$  inch in diameter. The tube is nearly filled with spirit, leaving a small air bulb, both ends are then blown together in order to hermetically seal the same ; the sides of the tube are not perfectly straight but slightly convex, thus facilitating the movements of the air bulb. The glass is placed in the mortise and set in plaster ; it is covered with a slotted brass plate screwed to the wood, exposing but a small portion of the glass. The brass plate has a centre line marked, and the glass is so set that when perfectly level the air bulb remains stationary, and exactly central in the slot. The level may be tested by turning it about on any plane surface until the bulb is central ; a mark should then be made on the surface, and the level turned about and applied to the mark ; if the bulb still remains central the level is correct. The stock should not be less than 9 inches in length ; in large work it varies commonly from 10 to 15 feet.

*The Chalk Line.*—This consists (as shown in Fig. 17) of a length of fine twine, and is used if it is required to fix a number of pieces of work in a straight line, or plane, where the length of the whole arrangement is too great to be spanned by a straight-edge, the latter being generally preferred to a line. When in use the line is strained between two known points and the other portions of the work adjusted to the line. The line is also employed, when cutting up planks of timber, for marking the cutting lines. In this case, the line is chalked and strained between two points previously determined ; the line is slightly raised from the centre and then suddenly snapped, a chalk impression being left on the timber. This method of marking is usually employed when

cutting the hard woods, the edges of the planks of which are generally crooked.

*Winding Strips.*—These are used in conjunction with the straight-edge in the preparation of timber for joinery to test for accuracy when forming plane surfaces. They consist of two pieces of some hard wood (straight grained mahogany to be preferred); they run from 18 inches to 2 feet in length, about 2 inches in width, and about  $\frac{1}{2}$  inch in thickness; their edges are kept perfectly straight and parallel. They are generally made feather-edged, *i.e.* one edge thinner than the other, so that they taper in transverse section. The use of these will be found described in a later chapter.

*Gauges.*—These are employed for marking lines parallel to the edges or faces of pieces of stuff when thicknessing or taking the same to a width. They consist of a stem and a movable fence; the stem is prepared from a piece of stuff about 9 inches in length and  $\frac{3}{4}$  inch square, the top edges of the stem being rounded, and about  $\frac{1}{2}$  inch from one end a piece of steel wire is driven, the projecting point being filed to a sharp point. The fence consists of a piece of stuff about 2 inches square and  $\frac{3}{4}$  inch thick; this has a hole through which the stem is passed; the fence may be secured at any point along the stem either by a wedge or screw. The drawing of a marking gauge is shown in Fig. 18. The mortise gauge (as shown in Fig. 19) is constructed similarly to the marking gauge, but has two teeth, one of which is movable to allow it to be regulated at any required distance within its limits from the fixed tooth. It is used, in framing, for making two parallel marks preparatory to cutting the mortise and tenons.

*The Striking Knife* is a tool of the shape shown in Fig. 20. It is employed for making cut marks on stuff in setting-out work.

## LESSON IV.—CUTTING TOOLS.

---

Cutting tools for wood may be divided generally into two kinds—first, the paring or splitting tools, for removing portions of the stuff in the direction of the fibres; secondly, tools, such as the saws, which may be used to divide the wood in any direction. Among the former there are the axes, chisels, gouges, and planes; and among the latter, saws and the boring tools.

*The Axe.*—There are two varieties of the axe in common use—the ordinary axe and the adze. The ordinary axe is employed by the carpenter for roughly removing extraneous portions of the work to be fixed or prepared. It consists of an iron head with a steel edge, of the shape shown in Fig. 21. The cutting edge of the axe is sharpened from both sides; if the edge be in a bad condition it is first ground on a grindstone, the keen edge being finally produced by means of an oil-stone. When great precision is required a side-axe is employed. This is only sharpened on one side; the flat side acts as a guide, and when slid along the surface of the stuff only takes off projecting portions; more may be taken off by gently inclining the face of the axe towards the stuff. The adze (shown in Fig. 22) is a modified form of the side-axe; it is used chiefly for roughly squaring logs of timber. The blade, or head, is slightly curved, and is sharpened on one side only; the shaft is about 3 feet in length and is fixed at right angles to the face of the blade. In using the adze, the workman stands upon his work, grasps the adze with both hands, and plants his blows with great effect and precision upon the stuff beneath his feet.

*Chisels.*—The chisels are divided into three classes: Firmer chisels, socket chisels, and mortise chisels. Chisels for carpentry and joinery work are sharpened on one side only, in order to render them capable of cutting



plane surfaces with approximate accuracy. The average length of the blades of chisels is about 6 inches. The firmer chisels have cast-steel blades, the socket and mortise have their blades of wrought-iron faced with steel. Wood working chisels have wood handles and are intended either to be propelled by the hand or driven by blows from a wood mallet—mallets are more effective than hammers in urging the chisels through the wood and are less destructive to the handles. The firmer chisels (as shown in Fig. 23) have the thinnest blades, and though occasionally driven with mallets they are especially intended to receive their motive power from the pressure of the hand, and should be used for paring off small portions of the stuff only. The blades vary in width from  $\frac{1}{8}$  to  $1\frac{1}{2}$  inches; the blades are often bevelled on their two long edges to enable the chisel to be worked into acute internal angles. The blade is fixed into the handle by means of a wedge-shaped tang, which is inserted into a hole bored into the handle; the tang is prevented from splitting the handle by having a shoulder formed about its base which keeps it from entering beyond its proper distance; in addition to this the handle is often provided with a ferrule. The socket chisel (as shown in Fig. 24) differs from the firmer chisel in having a much thicker blade and in having a socket formed on its upper end, instead of a tang, for the reception of the handle. The socket chisel is used for rough carpenter's work and for large work generally. The mortise chisel (as shown in Fig. 25), as its name implies, is used for cutting mortises. It has a very stiff blade, the thickness usually being greater than the width, in order that it may withstand the violent cross stresses to which it is subjected. It is constructed similarly to the firmer chisel, the handle being fixed in the same manner.

*Gouges.*—Gouges are chisels the blades of which have been bent in their width to a segment of a circle. They are sharpened on one face only, and may be either inside or outside, which signifies that they are sharpened

on the concave or convex face. Gouges are made as firmer or socket gouges, according as they are intended for light or for heavy work.

For wood carving, chisels and gouges are made to sharpen on both faces. The cutting edges are made of a great number of different shapes and sizes, and in many cases are bent in the direction of their length, in order to work in awkward corners and sunk or undercut surfaces.

*Planes.*—A plane is an apparatus in which the cutting iron is mounted, and its action modified so that the portion removed is of a uniform thickness. There is a great variety of planes constructed for various purposes, the principal among them being the jack plane, trying plane, smooth plane, rebate plane, shoulder plane, the bullnose, hollows and rounds, bead planes, compass plane, plough, fillister, and the spokeshave.

The jack, trying, and smooth planes are termed the bench planes, probably because they are used on nearly every piece of work that passes through the hands of the joiner. The object of these three planes is to reduce the rough sawn surfaces of timber to a smooth and even plane, this being accomplished by removing successive thin laminæ or shavings from the surface till the desired object is obtained. The arrangement of the cutting irons in the three planes is identical, being as follows:—first, as to the cutting irons (as shown in Fig. 26), these vary from about 2 inches to 2½ inches in width; they are of wrought-iron, the lower end being faced with steel. They are ground on one side only. In forming the edge the mass of the metal is taken off with the grindstone, the keen edge being finally formed with the oil stone. In the roughest planes the irons are single, but the majority of planes have double irons. The second, or back iron (as shown in Fig. 27), is much shorter than the cutting iron, but is of the same width. It is sharpened in the same way, and as it has no actual cutting to perform it does not require sharpening after

having been once set; it also has a sharp curve in its length towards its lower edge. The hollow side of the back iron is placed against the face of the first iron and is secured to it by means of a screw, the head of which passes through a hole and down the back side of the cutting iron along a slot formed in the same; the slot in the first iron allows the second to be adjusted as the first is being worn away. The iron is fixed in the plane by means of a wedge in an inclined position, the inclination varying between  $45^{\circ}$  and  $60^{\circ}$ , those with the steeper pitch being used for hard woods; the latter have, to a certain extent a scraping action combined with the cutting.

The thickness of the shaving when the plane has a single iron is regulated by the width of the mouth of the plane, but owing to the cut caused by the iron having a tendency to extend in advance of the cutting edge, a splitting or tearing action is induced. The cleft runs in the direction of the grain, which, if not parallel to the surface planed, the shaving is liable to become thicker and so choke the mouth of the plane, causing a ragged and torn surface. To obviate this defect the back iron is employed. This is screwed to the cutting iron and has its edge close to the cutting edge (as shown in Fig. 28), the distance between the two edges varying with the fineness or coarseness of the shaving required. The back iron has the effect of breaking the shaving immediately after it commences to rise up the cutting edge by suddenly changing its direction (as shown in Fig. 28), and thus, the shaving, having no stiffness nor length, has no leverage, and consequently no power to raise the grain in front of the cutting edge. In order to obtain a plane surface it is necessary that the cutting edge should be accurately sharpened. The edge should not be exactly straight, but form a segment of a very large circle, in order that the corners may not enter the surface at every stroke; the edge should on no account be concave.

The cutting edge of any bench plane iron is sharpened by pushing it rapidly backwards and forwards in an inclined position on an oil stone, the angle of inclination being maintained constant throughout the operation, the upper part of the plane iron being held firmly in the right hand, and the lower in the left, the iron being guided with the right hand, and the pressure applied with the left. When the iron is rubbed down sufficiently, it is wiped and stropped on the palm of the left hand to remove the loose steel remaining on the edge after sharpening. To remove the iron from the plane, a smart tap with the hammer on the top of the front end of the plane in the case of the jack and the trying, or on the back end in the case of the smooth plane, is sufficient to loosen the wedge. To set the iron, it is placed in position and held there with the thumb of the left hand; the operator glances down the face, and regulates the iron with his right hand until the edge is just visible above the surface. The wedge is then inserted and tightened by a few gentle taps with the hammer. This done, the iron can be set coarser or finer by gently tapping either the top of the iron or the end of the plane.

In order that the bench planes shall work correctly, it is necessary that the plane of the wearing faces be accurately kept; in order to do this they will require shooting at intervals, to correct any inaccuracy arising from warping of the stuff or from wear. While a plane is being shot, it should have its iron wedged into position with its cutting edge slightly below the surface, as a difference is likely to arise through the stock springing or bending slightly when the wedge is driven in. After much wear and successive shootings, the mouth of the plane grows wider; as the opening is one factor in determining the thickness of the shaving, it becomes necessary to repair the same, which is done by letting in small pieces of wood such as box or ebony, to reduce the size of the opening. It is common in smoothing planes

to have the front half of the plane of iron, fixed in such a manner that the mouth can be regulated, but these are not to be recommended, owing to the unequal rate of wear of the iron and wood in the face; it is always far better to have the whole of the face of iron.

*Jack Plane.*—The jack plane consists of a wood stock, as shown in Figure 29; it is about 17 inches in length and about 3 inches square in cross-section, having a rectangular hole for the reception of the iron of the shape shown in the figure, and to allow for the egress of the shaving. At the back of the stock there is a handle projecting from the upper surface. This handle is grasped and the plane is propelled by the right hand; any extra pressure required is imparted by the left hand, which also guides the tool in the forward stroke. The especial use of the jack plane is to remove the rough sawn surface of stuff and to bring the same to an approximately plane surface preparatory to trying it up.

*The Trying Plane.*—The trying plane (as shown in Fig. 30) differs from the jack plane in having a longer stock, and also a modification of the handle to increase its strength. The usual length of the stock is 1 foot 10 inches, but they are made much longer when extreme accuracy is required, as where the edges of boards are jointed; they are then termed jointing planes. The section of the stock is about  $3\frac{1}{4}$  inches square, and the iron  $2\frac{1}{2}$  inches in width. The trying plane is held and used in a similar manner to the jack plane. Its particular use is to form plane true surfaces and to shoot edges of boards straight. Owing to its great length, it is unable to enter the hollows of any irregular surface, and can only take off the projecting portions. The plane is worked over the surface until a continuous shaving can be taken off in any direction. The process of planing up a surface will be fully explained in Lesson 8.

*Smoothing Plane.*—The smoothing plane has a stock of the shape shown in Fig. 31; it is 8 inches in length,

and about 3 inches in width at the widest part; the width of the iron is about  $2\frac{1}{4}$  inches. The smoothing plane is used to put a finish on the work when it is together, by taking off a fine shaving from the already true surfaces.

*The Rebate Plane.*—This plane consists of a rectangular stock (as shown in Fig. 32) about 9 inches in length, about  $3\frac{1}{2}$  inches in width, and varying from about  $\frac{1}{2}$  inch to  $1\frac{1}{2}$  inch in thickness. It differs from the planes already described chiefly in the provision made for ejecting the shaving, and in having the iron the whole width of the face. The mouth of the plane and the cutting edge of the iron are on the skew, in order that a cleaner cut may be made. There is a conical-shaped hole in the side of the plane, a short distance above the face, from which the shaving is thrown out, this action being automatic owing to the shape of the hole. The rebate plane, as its name implies, is employed for forming rebates in the edges of boards or pieces of stuff.

*The Shoulder Plane.*—This is usually of metal, either gun-metal or steel, and is of the shape shown in Fig. 33, being from 6 inches to 7 inches in length. It is similar in principle to the rebate plane, the cutting edge of the iron extending over the whole width of the face; but it is square, not on the skew as in the previous example. The iron has a pitch of about  $25^\circ$ , and is fixed in the plane with the face containing the cutting edge downwards. The mouth is extremely fine, and allows only a very thin shaving to pass through. The plane is specially designed to cut across the grain.

*The Bullnose.*—This plane is similar to the shoulder plane, but shorter, the chief difference being that the cutting edge is taken to within about  $\frac{3}{16}$  inch of the front end of the plane. Its special object is to finish a flat surface which ends abruptly against some projecting member. The bullnose is shown in Fig. 34.

Another plane designed for a similar purpose to the bullnose, termed the chariot plane, is employed. The

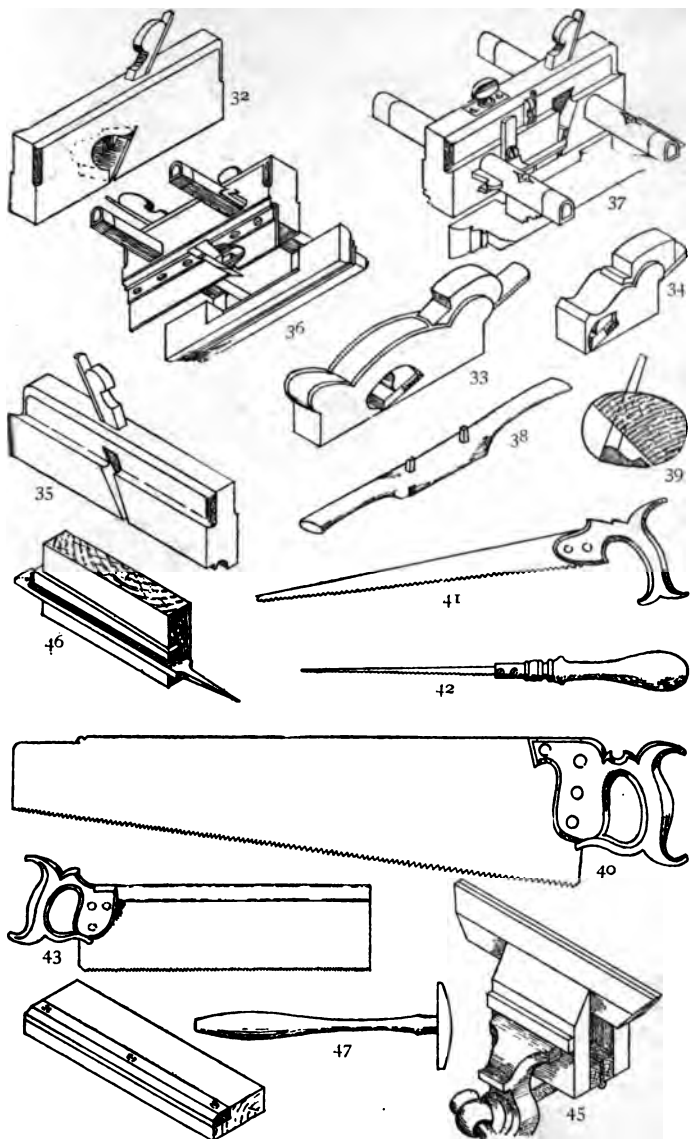

FIGS. 32 TO 43 AND 45 TO 47.

chariot differs from the bullnose in that the cutting iron does not extend over the whole width of the face.

*Hollows and Rounds.*—These planes are designed to work mouldings. The planes are made in pairs, having their faces worked to a segment of a circle. They are made in eighteen different sizes. The stock is about 9 inches in length, about  $3\frac{1}{2}$  inches in width, and varies in thickness from about  $\frac{1}{4}$  inch to 2 inches, according to the number. The irons may be fixed square or on the skew. The shaving escapes through an opening made in one side. These planes are similar to that shown in Fig. 35.

*Bead and Moulding Planes.*—These planes are identical in principle and construction with the hollows and rounds, differing only in having the reverse of a moulding worked on their faces instead of a plain segment. Fig. 35 is an illustration of a bead plane.

*Compass Plane.*—This plane is constructed similarly to an ordinary smoothing plane, but having its face worked in the direction of its length into a segment of a circle. It is used to work internal circular surfaces. Compass planes are now usually made in iron; the face consists of a thin sheet of flexible steel. Its advantage is that it may be adjusted within certain limits to a large number of curves, both convex and concave.

*Plough.*—An illustration of the plough is shown in Fig. 36. Its object is to form grooves in wood parallel to the face edge. It consists of a stock about 9 inches in length and about 3 inches in width. To the lower part of this is attached a thin steel plate to steady the cutting iron and regulate the thickness of the shaving. At the side of this plate is a movable stop to regulate the depth of the groove. It may be adjusted by means of a thumb-screw on the top of the stock to which it is connected, to any distance from the cutting edge up to its limit, and it may be fixed in its position by a set screw on the side of the stock. A movable fence is attached to the stock by two arms, the object being to



regulate the distance of the groove from the edge of the stuff. The stock is fixed at any point along the arms by means of wedges as shown. A set of eight irons is usually supplied with every plough, which vary in width by  $\frac{1}{16}$  from  $\frac{1}{8}$  inch to  $\frac{5}{8}$  inch.

*Fillister.*—This tool is practically a rebate plane to which is attached a movable fence (as shown in Fig. 37). The arrangement for the egress of the shaving is modified. A movable stop to regulate the depth of the rebate similar to the one on the plough is also affixed. In the better kinds, a vertical knife is fixed on the inside edge in advance of the cutting iron; this prevents a ragged cut in stuff that is not straight grained, and ensures a clean, sharp edge to the rebate. This tool is employed for working rebates on the back edges of narrow pieces of stuff such as sash styles.

*Spokeshave.*—This tool is designed to work sharp curves, either internal or external. It consists (as shown in Fig. 38) of a wood stock to the central portion of which a knife about 3 inches in length is attached, and terminates at both ends in a handle. The knife is turned up at both ends and passes through holes in the stock made to receive the same. Fig. 39 shows a section through the centre of the stock and the knife.

*Saws.*—A saw consists of a thin steel blade having a serrated edge formed by a number of triangular teeth worked on the same, the front edges of which act as so many knives. During every stroke of the saw each tooth individually cuts or tears a path for itself, and thus leaves a fresh surface for its successor to work upon, and by a repetition of such strokes a piece of timber may be severed in any direction.

The saws of the joiner may be classified as follows:—(1) tapering saws, (2) back saws, (3) frame saws. Under the first heading there is the half rip saw, the hand saw, the panel saw, the table saw, and the pad saw. Under the second there is the tenon and the dovetail saw. Under the third there is the frame or bow saw. The

teeth are triangular in shape, the cutting edge usually being kept at right angles to the back of the saw.

*Half rip Saw.*—The half rip saw is of the shape shown in Fig. 40. It consists of a thin steel blade slightly thinner on the back edge than on the front, to allow it to clear itself easily in the cut. The blade is about 28 inches in length, and about 9 inches at its wide and 4 inches at its narrow end. It has about three and a half teeth to the inch. The special use of the half rip saw is to cut wood in the direction of the grain, for which purpose it has such large teeth, as the resistance of the stuff in this direction is comparatively slight to that when a cut is made in the transverse direction.

*Hand Saw.*—This saw is constructed similarly to the rip saw. The blade is 26 inches in length, and about  $7\frac{1}{2}$  inches at the wide end, and 3 inches at the narrow end; it has from five to six teeth to the inch. The use of the hand saw is to cut stuff across the fibres, but it is also used for general purposes.

*The Panel Saw.*—This is of a shape similar to that of the hand saw. The blade is 24 inches in length, 7 inches at the wide end,  $2\frac{1}{2}$  inches at the narrow end, and has about seven teeth to the inch. It is used for cross-cutting thin stuff, and in cases where the jarring of a coarser saw would tend to split the stuff or would be detrimental to the work.

*The Table Saw.*—This saw is of the shape shown in Fig. 41. It has a tapering blade about 15 inches in length, it is about 2 inches at the wide end, and about  $\frac{3}{4}$  inch at the narrow end. The number of teeth varies from about seven to five to the inch. The use of the table saw is to work about curves of a fairly large radius.

*The Pad Saw.*—This saw is shown in Fig. 42. It has a blade about 1 foot in length, it is about  $\frac{1}{2}$  inch wide at the wide end, and about  $\frac{1}{8}$  inch at the narrow end, and has about nine teeth to the inch. The use of

this saw is to work about very small curves. Owing to the delicacy of the blade, and consequently its liability to breakage, provision is made to slide it back into the handle when not in use to protect the same. The blade is fixed in position when ready for use by the set screws shown.

*The Tenon Saw.*—The tenon saw has a much thinner blade than those previously described, and in order to stiffen the same a heavy brass or iron back is folded over the back (as shown in Fig. 43). In these saws the depth of the cut cannot exceed the width of the blade; they are therefore made parallel so as to obtain the maximum depth of cut. The ordinary length of the blade is 14 inches, and from 3 inches to 4 inches in width. It has about twelve teeth to the inch. Its special use is to make fine cuts across the grain, such as in cutting the shoulders of tenons.

*Dovetail Saw.*—The dovetail saw is practically similar in principle to the tenon saw, the only differences being its smaller dimensions and a slight modification of the handle; the blade is from 6 inches to 8 inches in length; it is very thin, and has about sixteen teeth to the inch. Its use, as its name implies, is to cut dovetails, and to make very fine cuts.

*Bow Saws.*—These saws are of the shape shown in Fig. 44 (p. 49); their object is to make curved cuts. In order to pass about very sharp curves the blades must be very fine and narrow; they vary from about  $\frac{1}{8}$  inch to  $\frac{3}{8}$  inch in width, and have from about twelve to eighteen teeth to the inch. As the blades possess very little stiffness, they are fixed in a frame as shown, and are subjected to a tensional stress by twisting the string fixed to the opposite ends of the sides to which the saw is fixed.

*Saw Sharpening.*—Every saw after using for a short time requires the cutting edges of its teeth renewed. As it is impracticable to apply a stone to the cutting edges of the teeth of a saw for the purpose of renewing the same, after they have become dulled, a three square

file is employed, the size of the latter varying with the size of the teeth to be filed. The teeth may be simply filed and the edges renewed, or, if in a bad condition, they may require remodelling. The latter operation is necessary at certain intervals for the following reason—the two extremities of a saw rarely get used, the central portion only getting much worn; in filing the teeth more is taken from the centre than from the ends to bring the teeth at that part to a state of efficiency; the edge of the saw thus tends to become concave or irregular. Thus the sharpening process may be classified under two heads: first, when the teeth require remodelling, and secondly, when they require to be retouched between the intervals of the former.

There are two general operations in sharpening a saw—viz. (1) filing, and (2) setting the teeth; the first is to renew the cutting edges, and the second consists in bending the teeth alternately to the right and left of the cutting edge; the object of the latter being to make the cut sufficiently large to prevent the blade of the saw from binding in the same.

In filing the teeth, the following points should be kept in view:—first, every tooth should be of a similar form; secondly, every tooth should be of a similar size, or, as in the case of tapering saws where the teeth slightly diminish towards the point, the reduction in size should be gradual and uniform; thirdly, the cutting edge of a saw should be perfectly straight; on no account should it be concave, but it may without disadvantage be slightly convex if the curve be kept perfectly uniform and does not change suddenly at any point in the length; the object of forming an edge convex is to correct the tendency of the latter becoming concave after retouching.

In setting the teeth, the following points should be considered:—First, every tooth should be inclined or bent over towards the opposite side to the one preceding it; secondly, every tooth should receive a

uniform amount of set ; thirdly, the smaller the amount of set compatible with efficiency the better.

Supposing a saw to be in a bad condition, the following four operations in their respective order would be gone through to effectively renew the cutting edge : (1) levelling, (2) remodelling, (3) setting, (4) sharpening.

*Levelling.*—The saw is gripped in a pair of saw-clamps, a common form of which is shown in Fig. 45 ; these have wood jaws from about 9 inches to 12 inches in length ; the edge is then rubbed down, *i.e.* levelled with a flat file which is fixed with its cutting face at right angles to a piece of stuff which serves as a guide, as shown in Fig. 46. With this the whole cutting edge may be made perfectly straight or slightly convex as desired.

After the edge has been straightened it will be found that the apices of nearly all the teeth have been rubbed away, and some very much more than others, thus rendering the remodelling of the same, which is the next operation necessary.

*Remodelling.*—The process of remodelling the teeth is conducted as follows :—The saw is fixed in the clamps commencing at one end of the blade and having the teeth projecting above the clamp sufficient to prevent the latter interfering with the use of the file. The file is then taken, the point between the thumb and fingers of the left hand and the handle in the right. The file is held perfectly horizontal, with its faces inclined at the required angle, and in using it should be pushed through firmly from point to haft at each forward stroke and perpendicularly to the face of the saw, and should be raised clear of the work at every return ; about six teeth are taken to commence with, a different tooth being operated upon at every stroke ; these are filed till they have been reduced to their triangular form again and the facets formed by the rubbing down have disappeared, care being taken to finish number one tooth

first, and then as each tooth is completed a fresh one is commenced, and this operation is repeated until all the teeth have been treated. At intervals in the process, the file should be placed in the first tooth to ensure the faces of the file retaining their original inclinations in the operator's grasp; by these means every tooth may be formed to the correct shape.

*Setting.*—A setting-block and hammer, as shown in Fig. 47, are required for this process. The setting-block is of wood, having on one edge of its upper face a strip of bar-iron let in flush and screwed to the block; a chamfer is taken off the edge of the iron, making about 20° with the face of the block. The blade of the saw is placed flat on the top face of the block, with the teeth projecting over the chamfer a distance depending on the amount of set required, and every alternate tooth is then given a smart blow with one point of the hammer. When every alternate tooth on one side is bent the saw is turned over and the process repeated. Many setting-blocks have movable guides to regulate the distance the teeth shall overhang the chamfer. There are several other contrivances for setting saws, the chief among which consists of a plate of steel with a number of cuts in the edge varying in size to accommodate the same to blades of varying thicknesses. The setting is accomplished by inserting the teeth one by one into one of the cuts mentioned, and then depressing one end of the set and so bending the tooth. It is difficult to obtain uniformity by this method, and the teeth are very apt to break unless the greatest care is exercised by glancing at the cutting edge from the back of the blade. It may be easily seen if the setting is uniform. The setting of a saw is a very important operation, and the correctness with which it is done materially affects the efficiency of the saw. If the setting is generally irregular, it causes the saw to jump and make a ragged cut; if there is more on one side than on the other, the saw has a tendency to run in the direction of the side that has the most set, and,

if there is too much set, a coarse ragged cut is made, the cutting goes on slowly, and the teeth become dulled rapidly.

*Sharpening.*—After the setting the sharpening proper commences. The saw is fixed in the clamps as in the remodelling process, beginning at the back end of the blade ; the file is held in the hands as before, but inclined point upwards at an angle of about  $10^{\circ}$  to the horizontal, and at the same time it is inclined at about  $10^{\circ}$  to the vertical with the point towards the handle of the saw. In this position the file should be pushed firmly forward from point to handle in every alternate incision between the teeth ; one or two strokes may be sufficient to sharpen each tooth, but as nearly as possible the same number should be given to each tooth to prevent a lack of uniformity. Care should be taken to send each stroke straight from end to end, and not to let the file rock or change its direction in its forward motion ; it is also important that the file should be steadily pressed downwards, so as to remove an equal amount of material from each side of the incision that is being operated upon ; if the file be pressed more against one side of the incision than against the other, the teeth will rapidly become irregular. The file should be lifted clear of the saw at every return stroke to prevent destroying the burr formed on the teeth and to economise the file. Every incision on both sides of the saw is treated as described, and when this is accomplished the saw is ready for use.

If the saw only requires touching up, the last process is all that is necessary.

## LESSON V.—BORING TOOLS.

The following are the chief among the boring tools: the bradawl, the gimlet, the auger, the brace and bits; among the latter there are the centre bit, the twist bit, the nose bit, the spoon bit, the quill bit, the rose countersink, the metal countersink, and the ordinary countersink.

*Bradawl.*—The bradawl is of the form shown in Fig. 48. It is used for boring holes in soft wood; it may be worked by the pressure of the hand only, or it may be driven by a hammer or mallet, in which case the edge of the bradawl should be placed across the fibres, and not in the same direction; if this be not done, the tendency will be to split the fibres. The bradawl is only useful for small holes.

*Gimlet.*—For boring small holes in hard wood the gimlet is employed. There are two kinds of gimlets, as shown in Figs. 49 and 50, the plain and the twist gimlet. The plain hollow or shell gimlet is the better for hard woods, as its action is slower than that of the twist gimlet; the advantage of the twist gimlet is that it removes the stuff as it is cut, but it has a greater tendency to split the material.

*Auger.*—Augers are large gimlets with a long stem and a movable handle about 1 foot in length, intended to be used with both hands. There are two kinds of augers—the shell and the screw. The shell augers are similar to the gimlet (Fig. 49), and require considerable pressure to urge them forward in addition to that expended in turning them. The screw augers (as shown in Fig. 51) are provided with a screw point which enters by itself; they are provided with cutting edges, and the helical surfaces remove the waste product.

*Brace.*—The brace is a tool of the form shown in Fig. 52, its object being to facilitate and increase the speed of the revolutions of boring tools. They are



formed of wood or steel, the latter material being preferred owing to its greater strength. Braces vary slightly in the arrangement for securing the bits. Many of the

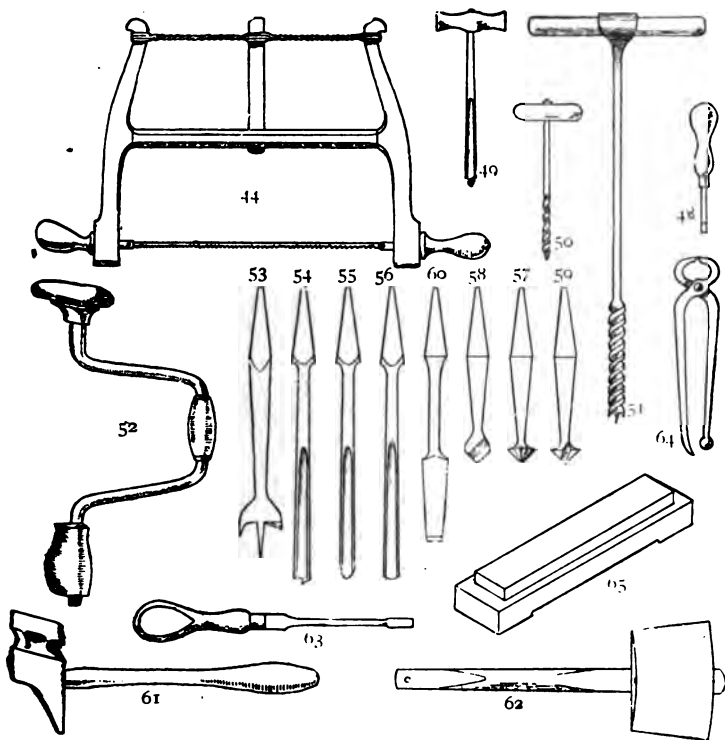

FIGS. 44, 48 TO 65.

braces, especially those of wood, have simply a square socket and a spring catch; in these the bits must be fitted to the socket. The steel braces usually have an expansible square socket, which can be adjusted to any bit.

*Centre Bit.*—The centre bit is of the shape shown in Fig. 53; it consists of a triangular pin in the centre,

a vertical knife edge and a horizontal cutter; the knife edge projects beyond the latter, and when the bit is made to revolve it makes a clean circular cut, the stuff from the interior of which is removed by the cutter in the form of a helical shaving. The centre bit is not well adapted for boring with the grain.

*Twist Bits.*—Twist bits are exactly similar to the screw auger, but are shorter, and have their ends adapted for fitting in the brace.

*The Nose Bit.*—This bit (as shown in Fig. 54) is formed of a circular piece of steel, hollowed out at the lower end, and provided at its extremity with a transverse cutter. It is specially adapted for boring with the grain.

*The Spoon Bit.*—The spoon bit is formed similarly to the nose bit, but does not possess the transverse cutter and is rounded at the point (as shown in Fig. 55). It is used for boring with the grain.

*The Quill Bit.*—The quill bit is formed similarly to the nose bit. It does not possess the transverse cutter, the end being finished as shown in Fig. 56. The extremities and edges of the hollowed out portion are sharp, in order to cut the fibres, the object of this bit being to bore holes across the fibres.

*Countersinks.*—These are employed for forming a conical sinking in the end of a hole to receive a screw head. There are three kinds: (1) the rose, (2) the metal, and (3) the ordinary or soft wood countersink.

1. *The Rose.*—This bit is shown in Fig. 57. The conical end has a serrated surface forming a number of cutters. This bit is used for countersinking holes in hard woods, or in soft metals such as brass.

2. *The Metal.*—This bit is formed similarly to an ordinary metal drill (as shown in Fig. 58); it is used for countersinking holes in iron.

3. *The Soft Wood.*—This tool has a plain conical end with one sinking (as shown in Fig. 59); its action is very rapid, and it is consequently only adapted for soft woods.

*Screw-driver Bit.*—This is shown in Fig. 60.

## LESSON VI.—MISCELLANEOUS TOOLS.

In addition to the tools previously mentioned, there are a number which cannot be classified under any special category, but have uses peculiar to themselves. Among these there are the hammer, the mallet, the screw-driver, the punch, the pincers, and the oil stone and slips.

*Hammer.*—Figure 61 shows the type of hammer usually employed by the joiner, who is ordinarily provided with three sizes for light, medium, or for heavy work.

*Mallet.*—The mallet is a wooden hammer, used for driving chisels with wood handles; those used by the joiner are of the shape shown in Fig. 62; the workman usually has two mallets—one for light bench work, and one for heavy work such as mortising.

*The Screw-driver.*—The screw-driver, as its name implies, is used for turning screws. Fig. 63 shows the type usually employed.

*The Punch.*—The punch consists of a short piece of steel bar, square or octagonal in section, forged and hardened similarly to a chisel, but having a small rectangular facet instead of a point. It is employed for imparting the finishing blows to nails, to prevent the surface of the wood becoming bruised by the face of the hammer, or in driving the nail head below the surface.

*The Pincers.*—The pincers are shown in Fig. 64; they are employed for extracting nails which have bent or are taking a wrong direction whilst being driven.

*The Oil Stone.*—Oil stones are pieces of soft, finely grained sandstone, employed to work the keen edge on cutting tools; they are cut to convenient sized pieces, about 9 inches by  $1\frac{3}{4}$  inches by  $1\frac{1}{4}$  inches, which are usually encased in wood, as shown in Fig. 65, to prevent breakage and for cleanliness. The following stones,

named from the places whence they are obtained, are in most general use: (1) the Canada stone, (2) the Washita stone, (3) the Charnley Forest stone, (4) the Arkansas stone, (5) the Turkey stone.

1. *Canada*.—This stone is rather coarse, of a greyish colour, soft, and quick cutting; is rapidly worn away; it is not good for tools requiring a very keen edge.

2. *The Washita*.—This stone is close grained, whitish in colour, fairly soft and quick cutting; will work a finer edge than the Canada, and is largely used among carpenters.

3. *Charnley Forest*.—This is a close grained stone of a greyish tint tinged with red; it is fairly hard and not very quick cutting; it will work a very fine edge sufficiently keen for joiner's work.

4. *The Arkansas*.—This has a very fine grain, is of a whitish colour; it is hard, wears away slowly, and is slow cutting; it is used where an extremely keen edge is required.

5. *Turkey Stone* is very fine grained, varies in colour from white to black; it is soft, wears quickly, cuts rapidly, and will work a keen edge.

*Slips*.—These are small pieces of oil stone, with shaped edges; they are used for sharpening shaped cutting edges, such as for gouges and the irons for moulding planes; they are prepared from any of the above-mentioned stones.

## LESSON VII.—SAWING.

By sawing is understood the separation or cutting of material with the length, or across the length of the fibres, by means of a tool with tooth-like projections, and impelled with an advancing reciprocating motion.

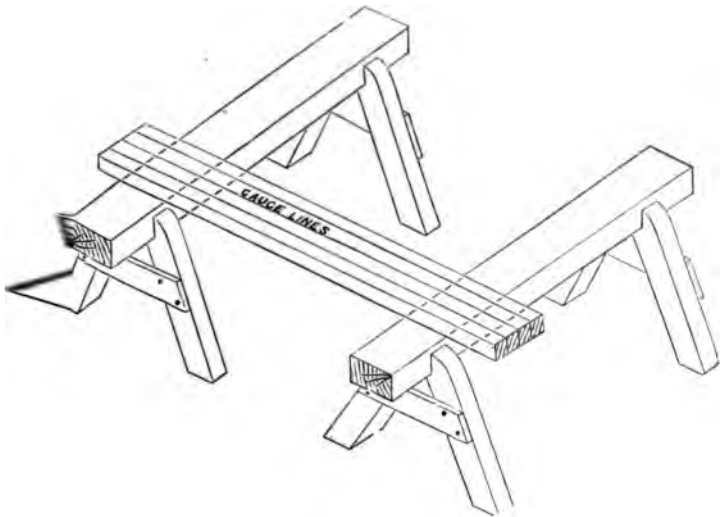

FIG. 66.

In using the saw, the following points may be noted :

- (1) The stuff should be kept in a rigid position, as, for instance, upon two stools, with the weight of the operator pressing upon it, or it may be fixed in the bench vice.

- (2) The cut is made by the forward stroke, which should be given with a uniform pressure. Care must be exercised (except in the case of the bow and pad

saws) that the movements of the saw are such that the surface of the saw, from the beginning to the finish of the cut, is in one plane, any departure from this condition causing the saw to buckle.

(3) The chest should be kept well forward, and the head erect.

Take a thick piece of stuff—say, a deal 12 feet long, 9 inches thick, 2 inches thick of northern pine. Place same on two stools, as shown in Fig. 66, with the clean wide face uppermost. Make parallel black-lead lines and from the straighter face edge, dividing the face into four equal parts. This may be readily accomplished by notching slips of wood, as shown in Fig. 124, to the required distances, as  $2\frac{1}{4}$ ,  $4\frac{1}{2}$ , or  $6\frac{3}{4}$  inches. Take a half rip saw, and begin cutting, always being careful to keep the face of the saw vertical. If properly sawn, the edges will be square with the faces.

## LESSON VIII.—PLANING.

Planing is the name given to the operation of preparing a smooth plane surface by means of tools which produce shavings; all irregularities, projections, or woolliness left by the saw on the face of the work being removed thereby.

*Exercise.*—Take a piece of American pine 2 feet long, 5½ inches wide, 1 inch thick. Take the rough off the two wide faces and one edge with the jack plane, and level the surfaces more exactly with the trying plane. Make one edge straight and square with the best face by using the jack plane to take the rough off, and make one edge straight by means of the trying plane, this being called shooting an edge.

Make a black-lead mark on the better face and shot edge. This is known as the tried-up mark, and the stuff is then said to be wrought on two faces and one edge.

## LESSON IX.—PREPARING PRISMS.

Take a piece of American yellow pine to finish, 12 inches long,  $1\frac{3}{4}$  inches wide, and  $1\frac{3}{4}$  inches thick. Draw a circle at each end  $1\frac{3}{4}$  inches in diameter, and divide both into eight parts by drawing lines with bevel set at 45 degrees to tried-up face and line parallel to same, all to pass through centre, as shown in Figure 67. Draw lines perpendicular to these radial lines at the points

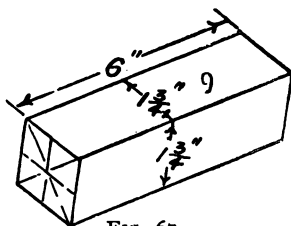

FIG. 67.

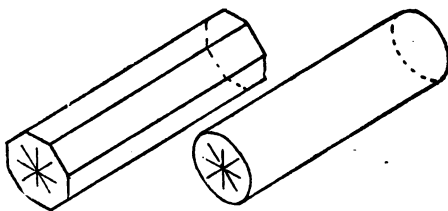

FIG. 68.

FIG. 69.

of contact with circle; these will describe an octagon, as shown in Fig. 68. Carefully plane arrises down to the outline, and an octagonal prism is the result. Cut the piece into two equal lengths, and, taking one of the pieces, plane the edges of the octagonal prism away to the circular outline, and thus a cylinder, as shown in Figure 69, is formed. In ordinary workshop practice, a zinc mould is made, and placed at the end sections, and the outline marked with a pencil.



LESSON X.—SHOOTING AN EDGE.

Take a piece of American yellow pine, 4 feet long,  $3\frac{1}{4}$  wide, and  $\frac{3}{4}$  inch thick, perfectly flat, straight grained, without sap, knots, or shakes.

Take rough off the wide faces and shoot a selected edge. Test if quite straight in the following manner:—  
Let straight-edge rest on a clean flat board as in Fig. 71,

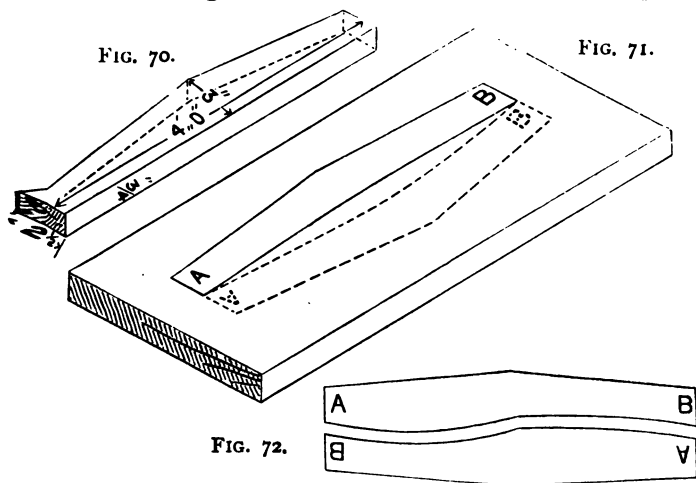

and press with black-lead pencil against edge to mark on board the outline of shot edge, as shown in dotted lines in Fig. 71, then simply turn piece over and mark outline of edge as before. If perfectly straight, both markings will coincide; if not, the error will be exaggerated. If there be any error, shoot off where required till edge is perfectly straight.

It must be carefully noticed in marking outline of edge on board, that the piece must not be turned end for end, as it would be quite possible, in some instances, for edge outlines marked in that manner, to coincide, and yet not be straight as in Fig. 72.

## LESSON XI. PREPARING WINDING STRIPS.

Take a piece of straight grained hard wood, oak or mahogany preferred, thoroughly seasoned and without a knot, 1 foot 6 inches long, 2 inches wide, and 1 inch thick.

Prepare the same with the jack and trying planes, making one wide face perfectly flat and one edge straight, and place tried up mark. Set the marking gauge to  $\frac{7}{8}$  inch. With the gauge mark the finished

DIMENSION LINE

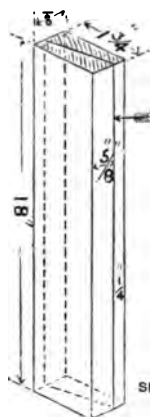

SHOWING GAUGE LINE  
FIG. 73.

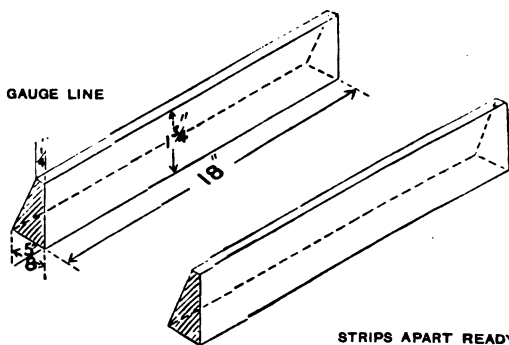

STRIPS APART READY  
FOR USE

FIG. 74.

thickness on edges, from the tried up face plane the piece now to thickness, then alter the gauge to  $1\frac{3}{4}$  inch, and run the same along tried up edge, marking on the wide face a parallel line. Plane edge to required width. Alter the gauge to  $\frac{1}{4}$  inch and mark the opposite-edges from the opposite faces. Join the gauged lines at the ends with pencil lines. Cut down carefully with the hand saw and plane the rough off the sawn faces. The wide faces may be smoothed with the smoothing plane, but edges must not be planed after being shot.

## LESSON XII.

### TAKING STUFF OUT OF WINDING.

Take a piece of northern pine 2 feet long,  $4\frac{1}{2}$  inches wide, 1 inch thick, and place upon the bench, and with winding strips at each end, look to see if one corner is higher than the other; the winding strips being wider than the board will multiply the error, if any, and this is readily seen when one eye is closed and the other is taking

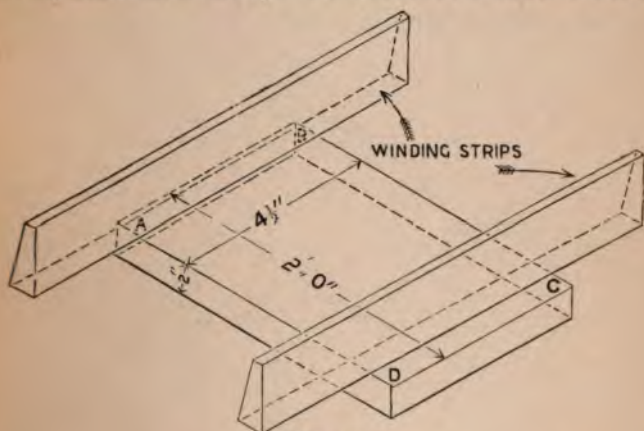

FIG. 75.

the two upper edges of winding strips at a glance. If one corner, say A, appears high, the thickness at that and at the opposite corner C should be measured, and that part of the face, nearer the thicker of the two, should be planed down to equal the thickness of the opposite corner. Apply winding strips, and if the same corner should still appear high take off equally on the face at A and C till the winding strips appear level. Plane the surface, so that a straight-edge applied between any two points is resting wholly on the surface, and the trued surfaces at corners A and C are retained.

## LESSON XIII.—SQUARE EDGE JOINTING.

Take two pieces each 1 foot long,  $5\frac{1}{2}$  inches wide, 1 inch thick, American yellow pine free from sap, knots, or other defects.

Plane wide faces and take out of winding with the jack and trying planes. Determine edges to be shot. They should be dry, free from sap or knots, and those should be preferred which, when glued together, show adjoining faces of similar colour.

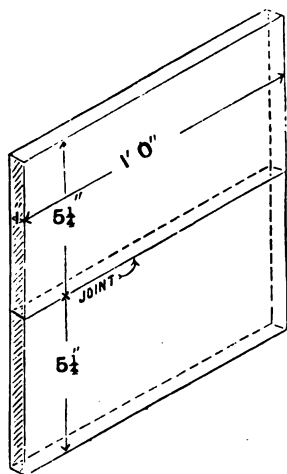

FIG. 76.

Shoot edges, and test the straightness by offering them together and placing them between you and the light. If no joint can be seen, and both tried up faces form one plane, they are ready to be glued up, which should be done at once. The glue should be strained and while hot put on with a glue brush, and the joint well rubbed backwards and forwards about four or five times to remove all unnecessary glue or any grit that may get in.

## LESSON XIV. GROOVE AND TONGUE JOINTING.

Take two pieces each 12 inches long,  $5\frac{1}{2}$  inches wide,  $\frac{3}{4}$  inch thick, clean white fir, to form a panel. Plane the same on the wide faces and shoot one edge of each.

Prepare cross tongues, which are sometimes called

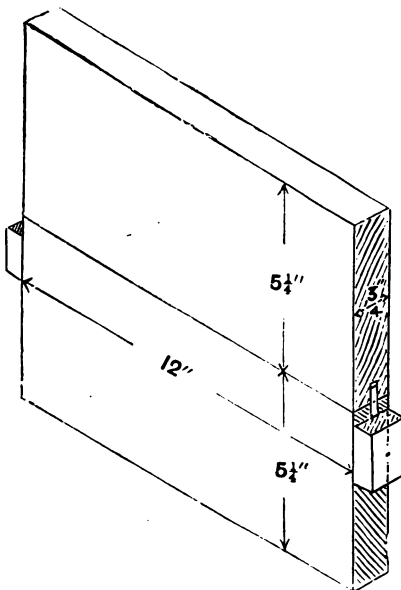

FIG. 77.

**feathers**, by cutting them from a sheet of pine about 11 inches wide and  $\frac{3}{16}$  inch thick in the following manner. Cut, with tenon saw, one end of veneer perfectly square. Set the cutting gauge to  $\frac{7}{8}$  inch, and if the gauge-knife is sharp, and is worked truly against this prepared edge,

it will cut off a parallel piece across the grain, leaving a fair edge on the thin board, and by repeating this operation as many tongues as required can now be cut.

Groove in the centre of shot edges of boards with plough set with iron slightly larger than thickness of cross tongues, to the depth of  $\frac{1}{2}$  inch. Re-shoot the joint, glue the tongues, having already taken the precaution to temporarily fix small blocks of wood at ends of lower board, as shown in Fig. 77, not quite covering the groove, so that the joint may be rubbed without the tongues falling out. Glue and rub well both shot edges against each other.

## LESSON XV.—REBATING.

Take two pieces of American yellow pine 2 feet long,  $1\frac{5}{8}$  inches wide, 1 inch thick, and prepare to  $1\frac{1}{2}$  inches wide,  $\frac{7}{8}$  inch thick.

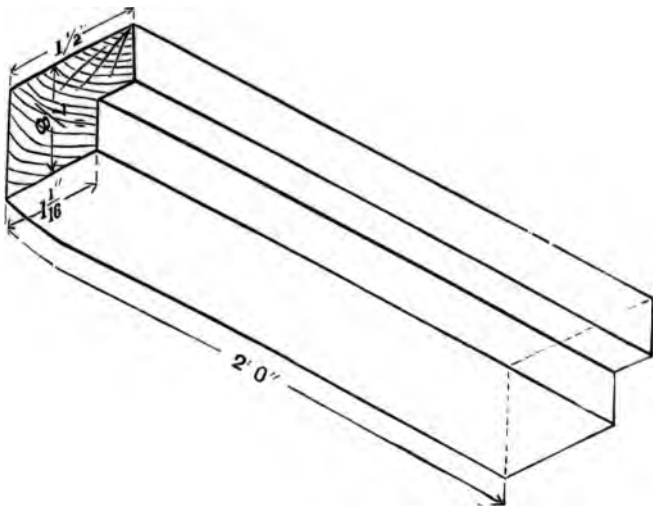

FIG. 78.

With marking gauge set  $\frac{7}{16}$  inch, mark position of rebate. Plough groove, and finish square with rebate plane, as shown in Fig. 78.

## LESSON XVI.—HOUSING.

Prepare two pieces of American yellow pine to finish, 6 inches long, 6 inches wide, and  $\frac{7}{8}$  inch thick. Set out and sink stopped housing on one piece, and mark and

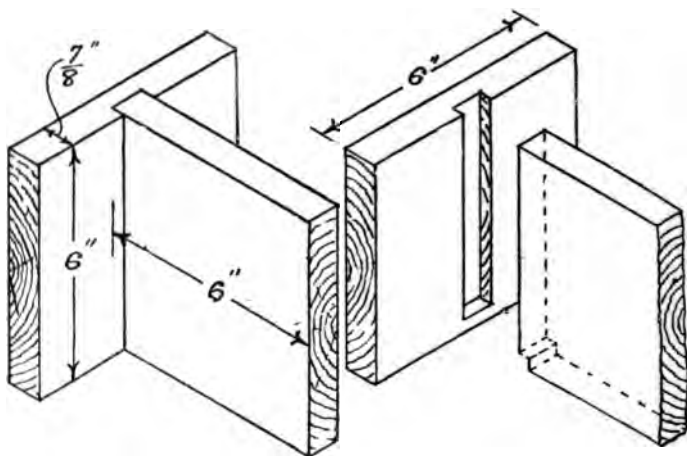

FIG. 79.

FIG. 80.

cut shoulder as shown in Fig. 80. Fit pieces together which should be at right angles to each other, as shown in Fig. 79. Housing is the name given to one part with an undiminished thickness fitting into another.



## LESSON XVII.—NOTCHING.

Take a piece of northern pine 18 inches long,  $2\frac{1}{4}$  inches square, and prepare to a width and thickness of 2 inches. Set out at one end with cut lines the piece 9 inches long to be notched as in Fig. 81.

Cut the shoulders with tenon saw, and make another cut as shown by dotted lines; clear out with sharp  $1\frac{1}{4}$ -inch chisel all material between shoulders leveling to the gauge lines. Cut the notched length off and fit together.

*Test.* — Fit pieces together, and try (1) if the joint is accurately made by noting if

the shoulders fit exactly, and that the faces of the members are square with each other, both horizontally and vertically; then (2) take the pieces apart and turn the upper piece end for end in the same plane relative to the lower member and fit together, and test as before.

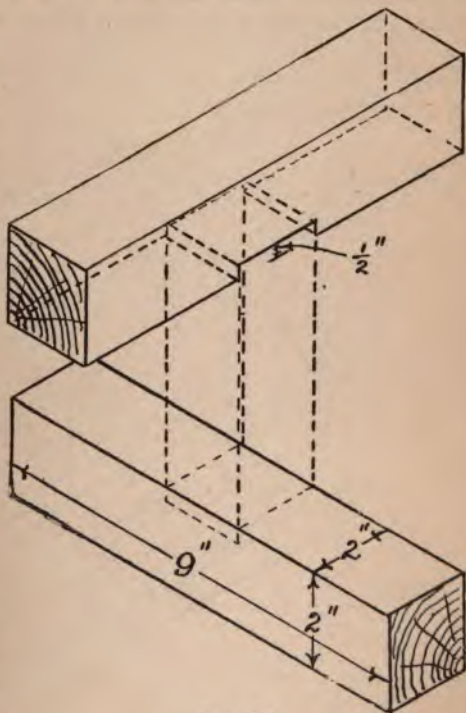

FIG. 81.

## LESSON XVIII.—COGGING.

Take two pieces each 9 inches long,  $2\frac{1}{4}$  inches square northern pine, or it is easier to work one length 18 inches long, and prepare to width and thickness of 2 inches

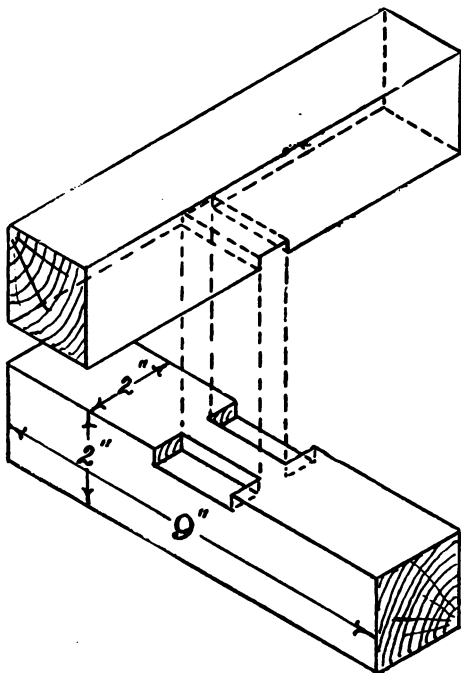

FIG. 82.

Set out with cut lines pieces to be coggied as shown in Fig. 82. Cut shoulders of grooved piece with a saw, and clear out with sharp, firmer chisel and shoulders of coggied member with tenon saw and chisel. Test the fit in the manner described for notched

LESSON XIX.—MORTISE AND TENON.

Take two pieces each 9 inches long,  $3\frac{1}{4}$  inches wide,  $1\frac{1}{2}$  inch thick, of northern pine.

Take the pieces out of winding and prepare to a width of 3 inches and  $1\frac{1}{8}$  inch thick. Set out piece for mortise with cut lines made by knife (cut lines are

FIG. 84.

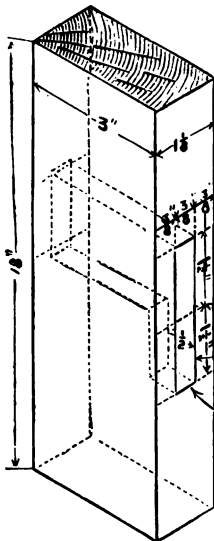

FIG. 83.

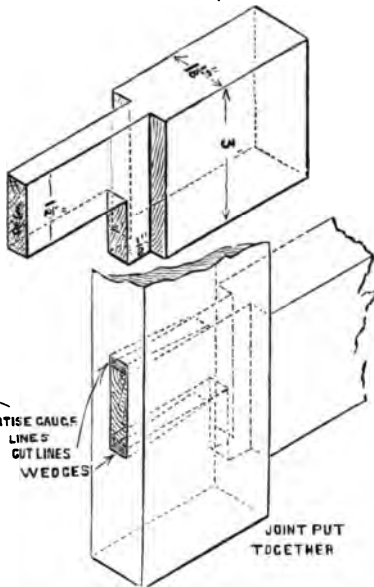

FIG. 85.

more exactly worked to than pencil lines) as shown in Fig. 83. Mortise same with chisel  $\frac{3}{8}$  inch wide, cutting space for wedges at back edge, and grooving out on tried up edge to receive the haunchion of tenon.

Set out piece for tenon, by marking from tried up face at end with mortise gauge set to the thickness and position of tenon. Best proportions of tenon as follows:

thickness of tenon equals  $\frac{\text{thickness of material}}{3}$

width of tenon equals 4 or 5 times thickness, but is not usually made wider than 2 to  $2\frac{1}{2}$  inches, wide tenons being objectionable, as they may shrink, and thus cause the wedges to become loose.

Cut the tenon with hand saw, or, when well practised, with half rip saw. Cut the shoulders with tenon saw, and mark with black-lead width of tenon  $1\frac{1}{2}$  inch. Set out haunchion as in Fig. 84 to keep rail from twisting. The piece of tenon that is to be cut away is sometimes used to cut the wedges from.

LESSON XX.—DOUBLE TENON.

Prepare and take out of winding two pieces to finish, one 9 inches long, 3 inches wide,  $1\frac{3}{4}$  inch thick, northern pine, as for the lock rail of a door, and one 9 inches long,  $4\frac{1}{2}$  inches wide,  $1\frac{3}{4}$  inch thick, as part of the style of a door.

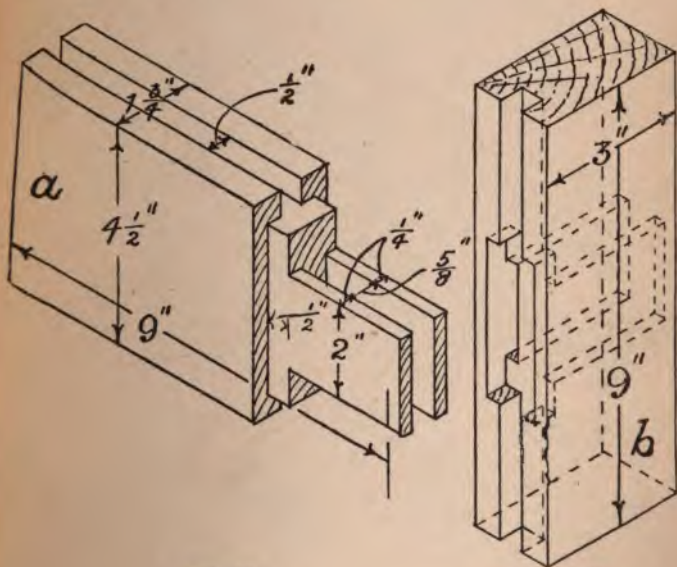

FIG. 86.

FIG. 87.

Set out piece A as shown in Fig. 86, tenon, groove, cut shoulders, in the order respectively stated; cut the tenons to width and form haunchion.

Set out piece B, groove and mortise as shown in Fig. 87.

As the rail is driven in, the wedges open the tenon to fit the dovetail mortise. If this operation is performed successfully any shrinkage in the style will not show open shoulders.

*Object.*—The aim of fox-tail wedging is to secure pieces of stuff together: where it is inconvenient to mortise to the whole width of the style, either through the style being very wide, or when it is undesirable to see the end grain of the tenon on the edge of the style.

LESSON XXII.—FOX-TAIL WEDGING.

Prepare two pieces of American yellow pine, 9 inches long, 4 inches wide,  $1\frac{1}{8}$  inch thick, for a rail and a style.

Set out the rail and style to the dimensions given in Figs. 90 and 91, and cut the tenon and the taper haunchion

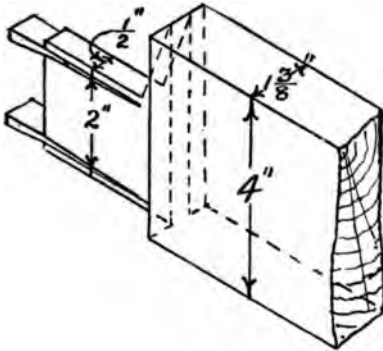

FIG. 90.

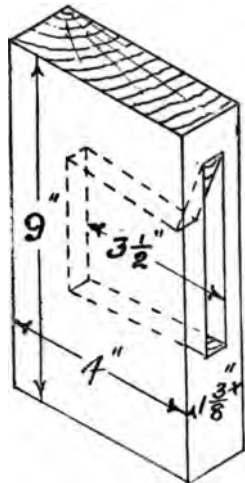

FIG. 91.

chion (the latter is known as a cabinet-maker's haunchion), and form the dovetailed mortise in the style, carefully making the mouth of the mortise the same size as the width of the tenon, so that the tenon enters tightly the splayed mortise; then fit two small wedges in saw cuts made in the tenon about  $\frac{3}{16}$  inch from each edge, as when the members are forced together the sides of the tenon spread more easily without splitting the rail, which is likely to happen when the wedges are placed nearer the centre.

As the rail is driven in, the wedges open the fit the dovetail mortise. If this operation is performed successfully any shrinkage in the style will not open shoulders.

*Object.*—The aim of fox-tail wedging is to join pieces of stuff together: where it is inconvenient to cut a mortise to the whole width of the style, either the style being very wide, or when it is undesirable to see the end grain of the tenon on the edge of the style.



## LESSON XXIII.—DOWELLING.

Take two pieces of American pine 12 inches long to finish 4 inches wide,  $\frac{7}{8}$  inch thick. Mark off with pencil lines position of dowels, then bore with  $\frac{3}{8}$ -inch twist bit  $\frac{1}{2}$  inch deep both pieces.

Take a piece of very hard wood, say oak  $\frac{3}{4}$  inch thick, and bore two holes; this will form the dowel gauge.

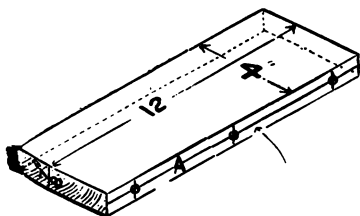

FIG. 92.

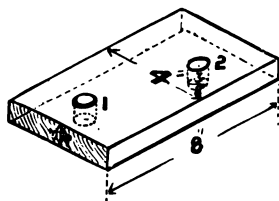

FIG. 93.

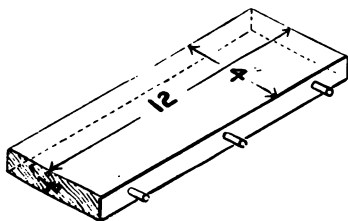

FIG. 94.

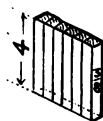

FIG. 95.

Take, to make the dowels, a piece of straight-grained oak wood 4 inches long,  $\frac{3}{8}$  inch thick, and with the chisel split asunder in squares slightly larger than diameter of hole in dowel gauge, pare off arrises with chisel to form the  $\frac{3}{8}$ -inch circular dowels, and drive same through dowel gauge. The constant use would tend to make gauge hole larger, so it is wise to let them pass through No. 2 hole. Steel plates with gauge holes are usually adopted

in practice. The oak dowels are then glued into one piece, and the projection is cut to the required length and the dowel pared to enter easily into the bored holes of the adjacent member. The dowel gauges are best out of steel.

Sometimes square or rectangular dowels are used instead of circular. This would necessitate rectangular slots, but the extra time taken in mortising would cause it to be more expensive.

## LESSON XXIV.—DRAW-BORING.

Prepare two pieces northern pine to finish 9 inches long, 2 inches wide,  $1\frac{3}{4}$  inch thick. Set out, mortise and tenon. If ends are to project, as in frames built in walls, the tenon may be the full width of material. The mortised members are bored with  $\frac{1}{2}$ -inch twist bit in the position illustrated, after which the tenons are fitted in

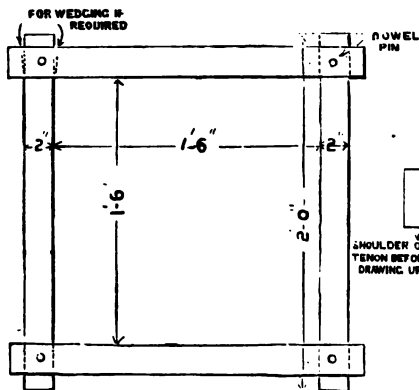

FIG. 96.

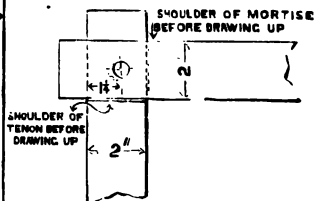

FIG. 97.

and position of bore marked. They are taken apart and tenon bored not exactly where marked, but towards the external corner of shoulder of tenon, as shown in Fig. 97, which represents the joint before dowel is forced through. This eccentric boring has the effect, when dowel pin is driven by heavy blows, of pulling the shoulders tightly together. After the tenon is pulled up it may be wedged, provided a space for wedging has been mortised, or simply kept in position by the dowel, which with all the surfaces of the joint is coated with white lead if used in external situations, or with glue for internal work.

## LESSON XXV.—SCARFING.

Joints to lengthen timber, as in Fig. 98, to resist tensional, and, as in Fig. 99, to resist compressional, stress.

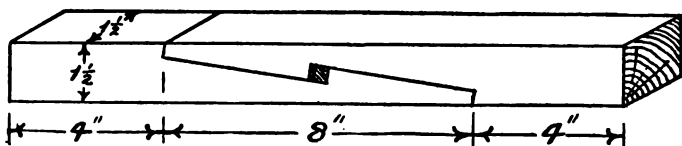

FIG. 98.

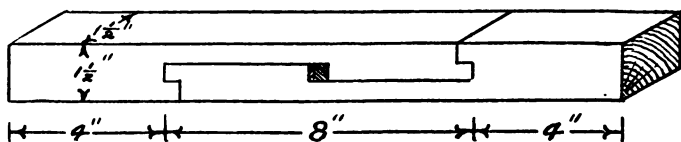

FIG. 99.

Prepare one piece each of mahogany and American yellow pine 12 inches long, 1 1/2 inch wide, 1 5/8 inch thick, northern pine for each scarf. Set out with cut lines, and cut as shown in Figs. 98 and 99.

The folding wedges should be cut out of oak.

## LESSON XXVI.—KEY JOINT.

Prepare two pieces of yellow pine each 22 inches long, 8 inches wide, and  $\frac{3}{4}$  inch thick. Make "square" joint as shown in Fig. 76. Prepare one piece 17 inches long, 3 inches wide,  $\frac{3}{4}$  inch thick; cut same with splayed cut into two pieces each  $1\frac{1}{8}$  inch at one end,  $1\frac{5}{8}$  inch at

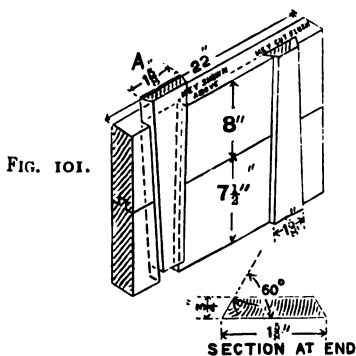

FIG. 101.

FIG. 100.

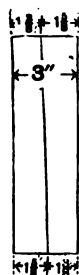

FIG. 102.

the other, splay edges as shown in Fig. 102. Cut splayed groove for key in the glued board across the grain, cutting splayed shoulders with tenon saw, and clear out with chisel and router, carefully making sunk face the width of the keys, measuring from narrowest end. Then fit the keys. If they are slightly larger than the housing as at A (Fig. 101) shavings are taken off the splayed edges of keys till a satisfactory joint is made.

This may, when finished, be useful as a drawing board.

## LESSON XXVII.—LAP HALVING.

Prepare two pieces American yellow pine to finish, 6 inches long,  $1\frac{3}{8}$  inch wide, and  $1\frac{3}{8}$  inch thick. Set out both pieces from face side and edge of the shouldered member, and mark with gauge the thickness of halving

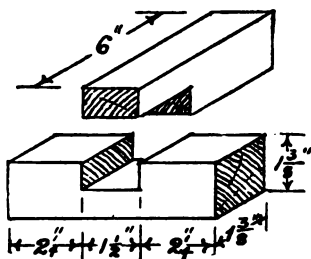

FIG. 103.

on both pieces, and cut the shouldered member. Apply the line over the part to be sunk, and mark the width with the striking knife, and from these points draw lines square across and sink the same. Fit members, as shown in Fig. 103, and clean off. If the work has been accurately gauged, squared and worked it will fit when tried at either side.

## LESSON XXVIII.—DOVETAIL HALVING.

Prepare two pieces American yellow pine to finish, 6 inches long,  $1\frac{3}{8}$  inch wide, and  $1\frac{3}{8}$  inch thick. Set out both pieces from face side and edge, and mark with gauge the thickness of the halving. Cut the dovetail and shoulder, then remove the lower cheek. Apply the

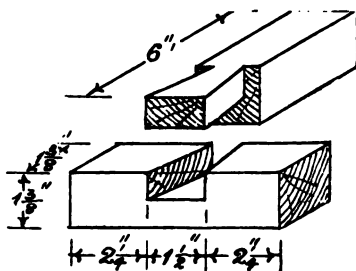

FIG. 104.

shouldered member over the part to be sunk, and insert the point of dovetail saw in the saw cuts and mark dovetail, square the marks on the edge to the gauge line, and cut inside of the marks made by tenon saw to allow for the thickness of the saw cut. Sink this member, and remove the side cheeks from the dovetail, fit members, as shown in Fig. 104, and clean off. If the work has been accurately gauged, squared and worked, the faces will be in one plane, and the edges at right angles to each other.

## LESSON XXIX.—HALVED MITREING.

Two pieces northern pine 9 inches long, prepared to finish  $1\frac{1}{2}$  inch wide,  $\frac{7}{8}$  inch thick. Set out with striking knife the mitres with bevel set at  $45^\circ$ , and gauge

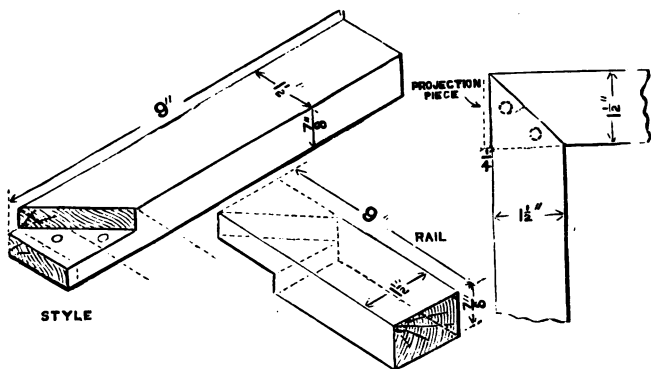

FIG. 105.

FIG. 106.

for halving. Cut pieces as in Figs. 105 and 106, and bore with fine bit. Fit together, glue same and screw from back as shown by dotted lines, as shown in Fig. 106. Cut and clean off projecting piece.



LESSON XXX.—BRIDLE JOINT.

Prepare two pieces American yellow pine to finish 6 inches long, 2 inches wide,  $1\frac{3}{8}$  inch thick. Set out both pieces from face side and edge with bevel and striking knife, and mark with mortise gauge; the inside of the lines should be cut. The bevel lines on the notched member

FIG. 107.

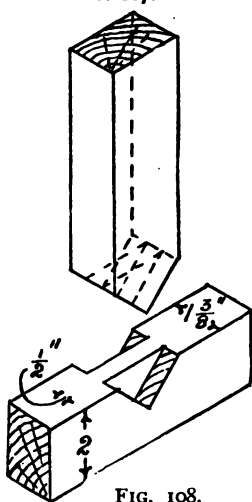

FIG. 108.

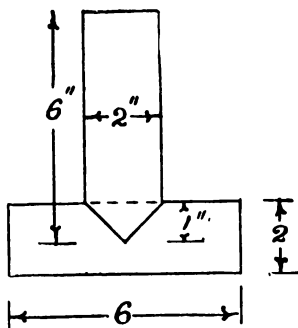

FIG. 109.

should be cut with a fine saw, and the stuff forming the triangular-shaped cheeks removed; and the material between the mortise gauge lines on the slotted piece cut out. This is done in both cases by means of a sharp chisel, carefully cutting to the centre of the gauge lines.

Fit members, as shown in Figs. 107, 108 and 109, and clean off. If the stuff has been accurately gauged and squared the faces will be in one plane and the edges at right angles to each other, and should fit when reversed.

## LESSON XXXI.—COMMON DOVETAIL.

Two pieces 6 inches long,  $4\frac{1}{4}$  inches wide,  $\frac{3}{4}$  inch thick, American yellow pine free from knots or sap. Prepare same to width of 4 inches and  $\frac{5}{8}$  inch thick, square ends and run marking gauge at ends for shoulder lines, the gauge being set  $\frac{1}{16}$  more than thickness of material, as shown in Fig. 112, to allow for cleaning off.

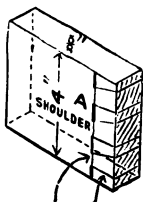

FIG. 110.

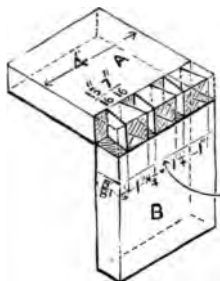
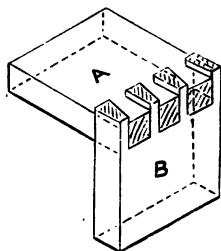

FIG. 111.

JOINT  
PUT TOGETHER  
FIG. 112.

Set out piece A (Fig. 110) for the mortises, and cut down to shoulder lines with dovetail saw.

Fix B vertically and rest A on B as shown in Fig. 111. Hold securely piece A and put dovetail saw in saw cuts marking for pins on end grain of B. Remove A and clean out mortises. Cut pins on B, carefully leaving saw marks on end grain so that pins may fit tightly.

Place pieces together to see if they make a good fit, after which turn the outside face of A over so that it becomes the inside face, then if the work has been set out symmetrically and cut carefully the joint will fit.

LESSON XXXII.—LAP DOVETAIL.

Prepare piece to finish 6 inches long,  $4\frac{1}{4}$  inches wide,  $\frac{7}{8}$  inch thick, and one piece 6 inches long,  $4\frac{1}{4}$  inches wide,  $\frac{7}{8}$  inch thick.

Set out piece A and cut the sides of the mortises

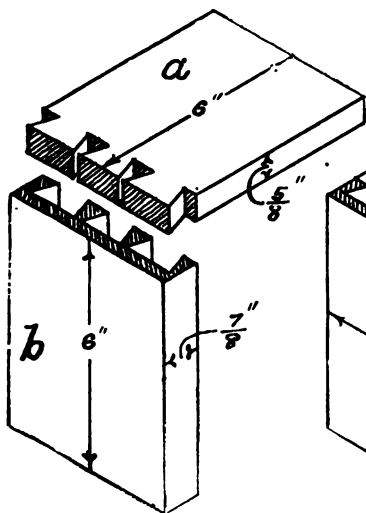

FIG. 113.

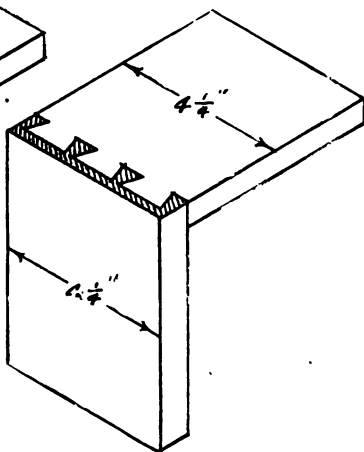

FIG. 114.

with fine dovetail saw. Apply the same to piece B (Fig. 113), making the end to coincide with the gauge line on the end of piece B. Mark pins with dovetail saw as before, and cut sides of pins with dovetail saw and remove the stuff between the same with sharp chisel. Careful working is especially necessary when cutting with the grain. Fit pieces together, and which may be tested in the same manner as the common dovetail.

## LESSON XXXIII.—DIMINISHED DOVE-TAIL AND BRACKET.

Take two pieces 9 inches square,  $\frac{3}{4}$  inch thick, northern pine, and prepare to sizes as shown in Figs. 115 and 116. Set out diminished dovetail housing, and :

FIG. 115.

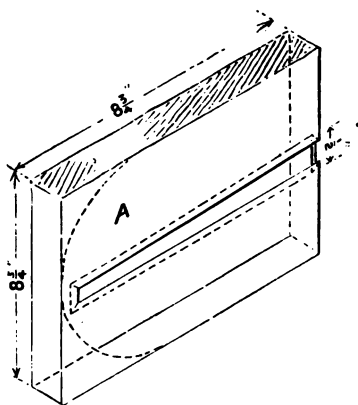

FIG. 116.

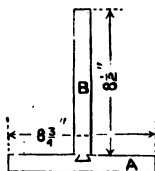
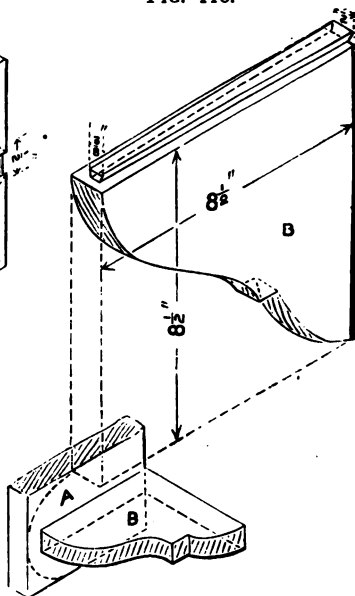

FIG. 118.

FIG. 117.

diminished dovetail as shown in Fig. 115, which may now be cut as shown by dotted lines and fitted as shown in Figs. 117 and 118. This is a good joint for uniting the horizontal and vertical members of a bracket.

## LESSON XXXIV.—SECRET DOVETAILED.

Prepare two pieces to finish 6 inches long,  $4\frac{1}{2}$  inches wide,  $\frac{5}{8}$  inch thick.

Set out and cut the pins and mitres shown on piece A (Fig. 120), and placing same on B mark the dovetails. These should be cut, just leaving the marks on the stuff to ensure that the member shall fit.

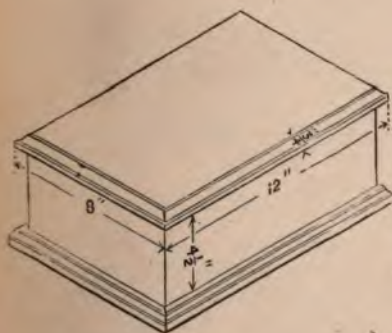

FIG. 119.

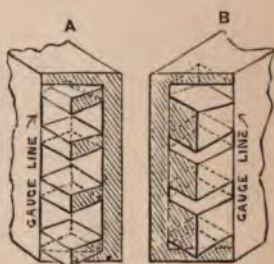

FIG. 120.

Prepare stuff for box shown in Fig. 119.

Set out and cut as shown in Fig. 120. Fit sides together and well glue up, forcing the unnecessary glue out of the joint by means of clamp or hand screw.

Prepare stuff for the top and bottom as shown in Fig. 119, screwing bottom to secret dovetailed sides, and hanging the lid with a pair of small brass butt hinges.

## LESSON XXXV. GROOVING AND MOULDING.

Take a piece 2 feet long to finish  $2\frac{1}{2}$  inches wide,  $\frac{7}{8}$  inch thick, American yellow pine, and groove with plough and iron as shown in Fig. 121.

The groove that is the greatest distance from the

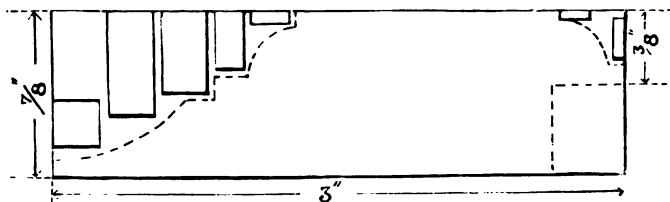

FIG. 121.

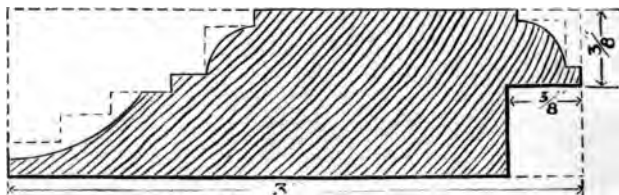

FIG. 122.

edge of wood against which the plough is worked should be made first.

Work with rebate plane all the sunk flat members of moulding as shown in Fig. 122, after which remove all superfluous stuff to the lines with the hollows and rounds.

## LESSON XXXVI.—CHAMFERING AND STOP CHAMFERING.

Take one piece rebated as in Lesson 15, and mark with pencil lines, by means of wood gauge set to  $\frac{1}{4}$  inch, and take off arrises with planes to pencil lines as in Fig. 125.

FIG. 123.

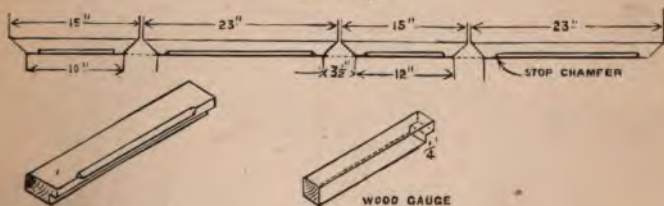

FIG. 124.

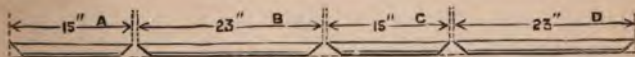

FIG. 125.

Take another piece rebated as before, and set out position of mitres in cut lines with bevel set to  $45^\circ$ . Mark for stopped chamfering, as in Fig. 123, with black-lead pencil and mitre template and cut away with sharp chisel as shown in Fig. 124. This is called stop chamfering.

## LESSON XXXVII.—MITREING A FRAME.

To make a frame 20 inches long, 12 inches wide inside measurement.

Take the piece rebated and chamfered as in the preceding Lesson, and cut it in a mitre box in the order as lettered. Plane it in a mitre shoot, then glue surfaces and brad as in Fig. 126. Care must be taken to hold corners firmly while being nailed.

Fig. 127 shows a method of glueing up mitred frames

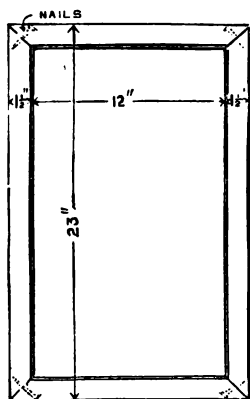

FIG. 126.

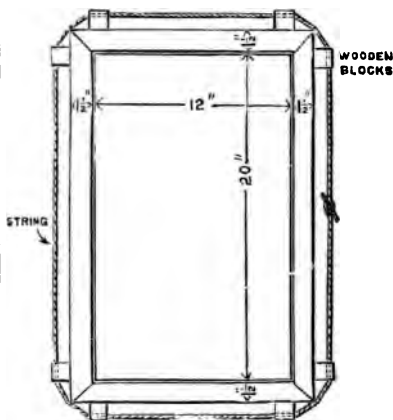

FIG. 127.

with blocks and string. The mitre is covered with hot glue, and the four pieces placed in position on a flat board. Blocks grooved to prevent the cord slipping are then placed against the outer part and near the centre of each member; the cord is then passed over the grooves of the blocks and tightened up. To obtain greater pressure the blocks are forced towards the mitred ends, and this has the effect of securely cramping the pieces together. When dry, the frame may be nailed or mitre-keyed.



LESSON XXXVIII.—KERFING (CONVEX).

Prepare pieces of American yellow pine of a clean and straight grain to finish 18 inches long, 2 inches wide,  $\frac{7}{8}$  inch thick. Mark a gauge line  $\frac{3}{32}$  inch from face on

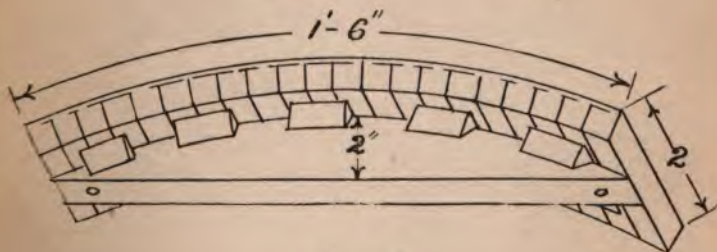

FIG. 128.

long edges. Set out and make saw cuts at back with intervals of  $\frac{3}{4}$  of an inch. Prepare piece shaped as shown in Fig. 128, 17 inches long, 2 inches wide at centre,  $\frac{7}{8}$  inch thick. Damp front face with clean hot water, and bend about shaped piece, and secure the extremities with screws and glue angle blocks at intervals, as shown in Fig. 128. If the work has been successfully accomplished no ridges will be discernible on face.

## LESSON XXXIX.—KERFING (CONCAVE).

Prepare a piece of American yellow pine of a clean and straight grain 18 inches long, 2 inches wide, and  $\frac{1}{2}$  inch thick. Mark a gauge line  $\frac{3}{32}$  inch from face on

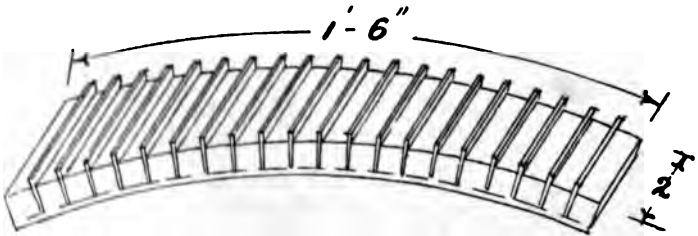

FIG. 129.

long edges. Set out and make saw cuts at back at intervals of  $\frac{3}{4}$  inch. Prepare shaped piece as shown in preceding exercise. Damp face of piece to be bent with clean hot water, and bend same over block, securing the extremities with hand screws. Prepare and fix with glue wedge-shaped strips, as shown in Fig. 129, to fit in the opened saw cuts, and when dry remove shaped block and clean off. If the work has been successfully accomplished no internal angles will be visible.

## LESSON XL.—VENEERING.

Stuff—that is, wood used by the joiner—is termed veneer when it is cut into thin sheets not exceeding  $\frac{1}{16}$  inch in thickness; it is usually prepared from rare or costly woods possessing a beautiful colour or grain. It is used to enhance the appearance of ornamental wood-work by covering parts of the same with a layer of a more strikingly marked piece of the same or other wood. Veneer may be laid on work in large sheets, or it may be cut into shaped pieces and laid to various designs. For the latter purpose veneers of different woods are often used in combination, and veneers may be dyed several different colours to obtain any desired effect.

To veneer a piece of stuff, the following processes in the order here given are usually carried out. First, the board to be veneered is scratched with a tothing plane, to remove any inequalities and to render the surface in a better condition to receive the glue.

The tothing plane has a stock similar to that of a smoothing plane; it has a single-iron pitched vertically. The face of the iron is grooved with a number of small grooves parallel to the side of the same, so that when the iron is sharpened from the back, as in the ordinary plane iron, the edge produced has a number of teeth.

If the board to be veneered is cut tangentially, the heart side should be chosen to be covered, in order that the natural tendency for the annual rings to straighten may always tend to keep the veneer taut. After having been scratched, the surface should be sized, to render it less porous, and at the same time the reverse side should be damped, to prevent the board from casting. The next process is to lay the pieces of the veneer on a board to match and joint the same. They are then temporarily secured in position to the surface with needle points. Strips of paper are then taken (damped on their upper

sides and glued on the other) and laid on the veneer over the joints. The paper, on drying, draws the pieces close together and makes neat joints. In fixing the veneer, the board should be covered plentifully with thin glue; the veneer is then placed in position, and is sometimes pressed on to the surface with a caul hammer, which serves to prevent the glue from setting in lumps beneath the veneer. The caul hammer, as shown in Fig. 130, is a tool similar to a rake, but having a horizontal piece of iron about 4 inches in length and  $\frac{1}{4}$  inch thick, with an edge straight in length and rounded transversely; this



FIG. 130.

is dragged backwards and forwards over the surface by commencing at the centre and working towards the edges; this should be done rapidly, and then a caul consisting of a piece of stuff the full size of the veneered surface, and perfectly flat (or if the veneered surface be curved the caul should be the reverse of the curve), should be fixed on the surface with cramps or hand-screws, if the surface be wide; the caul will require to be stiffened with transverse stiffeners, pieces of stuff of the required length and about  $4\frac{1}{2}$  inches by 3 inches in section. The caul should be left in position for from three to four hours to allow the glue to set; at the end of this time, the caul is removed and the work is left to dry. On wide surfaces in important work it is usual to veneer both sides of the work, because the veneer, in drying, contracts, and causes the surface on which it is glued to cast; but if the stuff be veneered on both sides the opposite tendencies preserve a true surface. When the work is dry, it is cleaned off with a fine plane scraper and glass paper.

# INDEX.

---

Actions of plane iron, 35  
Adze, 32  
American yellow or white pine, 13  
Angle blocks, 21  
Annual rings, 8, 11  
Arrangement of cutting iron in planes, 34  
Ash, 16  
Auger, 48  
Autumn wood, 8  
Axe, 32

## B

Back iron, 34  
Bark, 9  
Basswood, 17  
Batten, 21  
Bay wood, 16  
Beech, 17  
Bench planes, 34  
Bevels, 27  
Bits, 48  
Bolts, 19, 23  
Boring tools, 48  
Brace, 48  
Bracket, 84  
Bradawl, 48  
Brads, 19, 22  
Bridle joint, 81  
Broad-leaved trees, 13  
Buttons, 19, 20  
Butts, 85

## C

Cabinet-maker's haunchion, 71  
Cambium, 8  
Caul, 92

Caul hammer, 92  
Cedar, 17  
    " Odour of, 17  
Cellular tissue, 8  
Centre bit, 48, 49  
Chamfering, 87  
Chalk line, 30  
Chariot plane, 38  
Chisels, Carving, 34  
    " Firmer, 32  
    " Socket, 32  
    " Mortice, 32  
Circulation of sap, 9  
Classification of tools, 26  
Clout nails, Zinc, 23  
    " Copper, 23  
    " Composition, 23  
Cogging, 66  
Colour of timbers, 13, 14, 15, 16, 17, 18  
Compasses, 27  
Coniferous trees, 13  
Conversion, 9  
Corrosion of iron, 15  
Countersink rose, 48, 50  
    " metal, 48, 50  
    " ordinary, 48, 50  
Cramp, 85  
Cryptogams, 7  
Cutting iron, 34  
Cutting tools, 32

## D

Decay in timber, 12  
Decomposition of timber, 12  
Desiccating, 10  
Dogs, 19, 24  
Double tenon, 69

Dovetail halving, 79  
 Dovetail, Common, 82  
 „ Lap, 83  
 „ Diminished, 84  
 „ Secret, 85  
 Dovetailed housing, 84  
 Dowel gauge, 74  
 Dowelling, 73  
 Dowels, 19, 21  
 Draw boring, 75  
 Dry rot, 12  
 Durability of timber, 13, 14, 15,  
 16, 17, 18  
 Dyed veneers, 91

## E

Elasticity of ash, 16  
 Elm, 16  
 Endogens, 7  
 Exogens, 7

## F

Feathers, 61  
 Fastenings, 19  
 Felling, 9  
 Figure in timber, 9, 14  
 Filing saw teeth, 44  
 Fillister, 34, 41  
 Fixing chisels into handles, 33  
 French glue, 19  
 Fox-tail wedging, 71  
 Fungi, 12

## G

Galvanising, 24  
 Gimlet, 48  
 Glass paper, 92  
 Glue, 19  
 Glue pot, 19  
 Gouges, Inside, 33  
 „ Outside, 33  
 „ Firmer, 34  
 „ Socket, 34  
 „ for carving, 34  
 Grooving, 86

## H

Halved mitreing, 80  
 Hammer, 51

Handscrew, 85  
 Hard woods, 13  
 Haunchion, 71  
 Hollows and rounds, 34, 40  
 Housing, 77

## I

Iron-faced planes, 39  
 Iron straps, 19, 24

## J

Jointing square edge, 60, 77  
 „ groove and tongue, 61

## K

Kawrie Pine, 18  
 Kerfing, Convex, 89  
 „ Concave, 90  
 Keys, 19, 20  
 Key joint, 77

## L

Lap halving, 78  
 Larch, 18  
 „ for posts and railway sleep-  
 ers, 18  
 Levelling saw teeth, 45  
 Lignin, 12  
 Lime, 17

## M

Mahogany, 15  
 Mallet, 51  
 Marking gauges, 31  
 Maturity of timber, 9, 12  
 Medullary rays, 8, 11, 15  
 Method of glueing up frames, 88  
 Mitreing, 88  
 Mitre, Box, 88  
 „ Keyed, 88  
 „ Shoot, 88  
 „ Template, 87  
 Miscellaneous tools, 51  
 Moulding, 86  
 Moulding planes, 40  
 Mortice gauges, 31  
 Mortice and tenon, 67

## N

- Nails, 19, 21  
 ,, Wrought-iron, 22  
 ,, Cast-iron, 22  
 ,, Steel, 21  
 Natural seasoning, 10  
 Needle-leaved trees, 13  
 Needle points, 23, 91  
 Northern pine, 14  
 Nose bit, 48, 50  
 Nuts, 19

## O

- Oak, Sessiliflora, 15  
 Pedunculata, 15  
 Oil stone, 51, 52  
 Ornamental joinery, 14, 15

## P

- Paring Tools, 32  
 Phanerogams, 7  
 Pincers, 51  
 Pine, 13  
 Pitch of plane irons, 35, 38  
 Pitch pine, 13  
 Pith, 8  
 Plain gimlet, 48  
 Plane, Jack, 34, 37, 55  
 ,, Trying, 34, 37, 55  
 ,, Smooth, 34, 37  
 ,, Rebate, 34, 38  
 ,, Shoulder, 34, 38  
 ,, Bullnose, 34, 38  
 ,, Bead, 34, 40  
 ,, Compass, 34, 40  
 Planes, 34  
 Planing, 55  
 Plough, 34, 40  
 Plough irons, 41  
 Plumb rule, 28  
 Plummet, 28  
 Ports from which timber is obtained, 13, 14, 15, 16, 17, 18  
 Preparation of glue, 19  
 Preparing prisms, 36  
 Punch, 51

## Q

- Quadrant compasses, 27  
 Quill bit, 48, 50

## R

- Radial cut, 9, 15  
 Rebating, 63  
 Regulation of the thickness of shavings, 35  
 Remodelling saw teeth, 44, 45  
 Retouching saws, 44  
 Rubbing joints, 60  
 Rule, 26

## S

- Sapwood, 10  
 Saw clamps, 47  
 Sawing, 53  
 Saw, Sharpening, 43, 45  
 Saws, Tapering, 41  
 ,, Frame, 41  
 ,, Back, 41  
 ,, Half rip, 41, 42, 54  
 ,, Hand, 41, 42  
 ,, Panel, 41, 42  
 ,, Table, 41, 42  
 ,, Pad, 41, 42, 53  
 ,, Tenon, 41, 43  
 ,, Dovetail, 41, 43  
 ,, Bow, 41, 43, 53  
 Scarfing, 76  
 Scotch glue, 19  
 Scraper, 92  
 Scribing, 27  
 Screws, 19, 23  
 Screwdriver, 51  
 Screwdriver bit, 50  
 Screw auger, 48  
 Seasoning, 10  
 Selection of timber, 10  
 Set square, 26  
 Setting saws, 44, 45  
 Setting plane irons, 34  
 Setting-block for saws, 46  
 Setting-out tools, 26  
 Setting-hammer for saws, 46  
 Shakes, Heart, 10  
 ,, Star, 10  
 ,, Cup, 10  
 Sharpening plane irons, 36  
 Shell auger, 48  
 Shooting face of plane, 36  
 Shot edges, 55, 57  
 Shrinkage of timber, 11

*Selections from Cassell & Company's Publications.*

- Hispaniola Plate (1683-1893). By JOHN BLOUNDELLE-BURTON. 6s.  
Historic Houses of the United Kingdom. Profusely Illustrated. 10s. 6d.  
History, A Foot-note to. Eight Years of Trouble in Samoa. By ROBERT LOUIS STEVENSON. 6s.  
Home Life of the Ancient Greeks, The. Translated by ALICE ZIMMERN. Illustrated. *Cheap Edition*. 5s.  
Horse, The Book of the. By SAMUEL SIDNEY. With 17 Full-page Colotype Plates of Celebrated Horses of the Day, and numerous other Illustrations. Cloth, 15s.  
Horses and Dogs. By O. EEWELMAN. With Descriptive Text. Translated from the Dutch by CLARA BELL. With Photographic Frontispiece, 12 Exquisite Colotypes, and several full page and other engravings in the text. 25s. net.  
Houghton, Lord: The Life, Letters, and Friendships of Richard Monckton Milnes, First Lord Houghton. By Sir WEMYSS REID. In Two Vols., with Two Portraits. 32s.  
Household, Cassell's Book of the. Complete in Four Vols. 5s. each. Four Vols. in Two, half-morocco, 25s.  
Hygiene and Public Health. By B. ARTHUR WHITELEGGE, M.D. 7s. 6d.  
Impregnable City, The. By MAX PEMBERTON. 6s.  
India, Cassell's History of. By JAMES GRANT. With about 400 Illustrations. Two Vols., 9s. each. One Vol., 15s.  
Iron Pirate, The. By MAX PEMBERTON. Illustrated. 5s.  
Island Nights' Entertainments. By R. L. STEVENSON. Illustrated. 6s.  
Kennel Guide, The Practical. By Dr. GORDON STABLES. 1s.  
Khiva, A Ride to. By Col. FRED BURNABY. *New Edition*. With Portrait and Seven Illustrations. 3s. 6d.  
King George, in the Days of. By Col. PERCY GROVES. 11d. 1s. 6d.  
King's Hussar, A. Edited by HERBERT COMPTON. 6s.  
Ladies' Physician, The. By a London Physician. *Cheap Edition, Revised and Enlarged*. 3s. 6d.  
Lady Biddy Fane, The Admirable. By FRANK BARRETT. *New Edition*. With 12 Full-page Illustrations. 6s.  
Lady's Dressing-room, The. Translated from the French of BARONESS STAFFE by LADY COLIN CAMPBELL. 3s. 6d.  
Letters, the Highway of, and its Echoes of Famous Footsteps. By THOMAS ARCHER. Illustrated. 10s. 6d.  
Letts's Diaries and other Time-saving Publications published exclusively by CASSELL & COMPANY. (*A list free on application*.)  
'Lisbeth'. A Novel. By LESLIE KEITH. 6s.  
List, ye Landsmen! By W. CLARK RUSSELL. 6s.  
Little Minister, The. By J. M. BARNIE. *Illustrated Edition*. 6s.  
Little Squire, The. By Mrs. HENRY DE LA PASTURE. 3s. 6d.  
Lollandlaff Legends, The. By LOUIS LLOLLANDLAFF. 1s.; cloth, 2s.  
Lobengula, Three Years With, and Experiences in South Africa. By J. COOPER-CHADWICK. *Cheap Edition*, 2s. 6d.  
Locomotive Engine, The Biography of a. By HENRY FRITH. 3s. 6d.  
Loftus, Lord Augustus, The Diplomatic Reminiscences of. First and Second Series. Two Vols., each with Portrait, 32s. each Series.  
London, Greater. By EDWARD WALFORD. Two Vols. With about 400 Illustrations. 9s. each.  
London, Old and New. Six Vols., each containing about 200 Illustrations and Maps. Cloth, 9s. each.  
Lost on Du Corrig; or, 'Twixt Earth and Ocean. By STANDISH O'GRADY. With 8 Full-page Illustrations. 5s.  
Medicine, Manuals for Students of. (*A List forwarded post free*.)  
Modern Europe, A History of. By C. A. FYFFE, M.A. *Cheap Edition in One Volume*, 10s. 6d. Library Edition, Illustrated. 3 Vols., 7s. 6d. each.  
Mount Desolation. An Australian Romance. By W. CARLTON DAWKINS. *Cheap Edition*. 3s. 6d.



*Selections from Cassell & Company's Publications.*

- Music, Illustrated History of.** By EMIL NAUMANN. Edited by the Rev. Sir F. A. GORE OUSELEY, Bart. Illustrated. Two Vols. 31s. 6d.
- National Library, Cassell's.** In 214 Volumes. Paper covers, 3d.; cloth, 6d. (*A Complete List of the Volumes post free on application.*)
- Natural History, Cassell's Concise.** By E. PERCEVAL WRIGHT, M.A., M.D., F.L.S. With several Hundred Illustrations. 7s. 6d.
- Natural History, Cassell's New.** Edited by Prof. P. MARTIN DUNCAN, M.B., F.R.S., F.G.S. Complete in Six Vols. With about 2,000 Illustrations. Cloth, 9s. each.
- Nature's Wonder Workers.** By KATE R. LOVELL. Illustrated. 3s. 6d.
- New England Boyhood, A.** By EDWARD E. HALE. 3s. 6d.
- New Zealand, Picturesque.** With Preface by Sir W. B. PERCEVAL, K.C.M.G. Illustrated. 6s.
- Nursing for the Home and for the Hospital, A Handbook of.** By CATHERINE J. WOOD. *Cheap Edition.* 1s. 6d.; cloth, 2s.
- Nursing of Sick Children, A Handbook for the.** By CATHERINE J. WOOD. 2s. 6d.
- Ohio, The New.** A Story of East and West. By EDWARD E. HALE. 6s.
- Oil Painting, A Manual of.** By the Hon. JOHN COLLIER. 2s. 6d.
- Old Maids and Young.** By E. D'ESTERRE KEELING. 6s.
- Old Boy's Yarns, An.** By HAROLD AVERY. With 8 Plates. 3s. 6d.
- Our Own Country.** Six Vols. With 1,200 Illustrations. 7s. 6d. each.
- Painting, The English School of.** *Cheap Edition.* 3s. 6d.
- Painting, Practical Guides to.** With Coloured Plates:—
- |   |  |
|---|--|
| <p>MARINE PAINTING. 5s.<br/>ANIMAL PAINTING. 5s.<br/>CHINA PAINTING. 5s.<br/>FIGURE PAINTING. 7s. 6d.<br/>ELEMENTARY FLOWER PAINTING. 3s.</p> | <p>WATER-COLOUR PAINTING. 5s.<br/>NEUTRAL TINT. 5s.<br/>SEPIA, in Two Vols., 3s. each; or in One Vol., 5s.<br/>FLOWERS, and HOW TO PAINT THEM. 5s.</p> |
|---|--|
- Paris, Old and New.** A Narrative of its History, its People, and its Places. By H. SUTHERLAND EDWARDS. Profusely Illustrated. Complete in Two Vols., 9s. each; or gilt edges, 10s. 6d. each.
- Peoples of the World, The.** In Six Vols. By Dr. ROBERT BROWN. Illustrated. 7s. 6d. each.
- Photography for Amateurs.** By T. C. HEPWORTH. *Enlarged and Revised Edition.* Illustrated. 1s.; or cloth, 1s. 6d.
- Phrase and Fable, Dr. Brewer's Dictionary of.** Giving the Derivation, Source, or Origin of Common Phrases, Allusions, and Words that have a Tale to Tell. *Entirely New and Greatly Enlarged Edition.* 10s. 6d.
- Picturesque America.** Complete in Four Vols., with 48 Exquisite Steel Plates and about 800 Original Wood Engravings. £2 2s. each. *Popular Edition,* Vols. I. & II., 18s. each. [the Set.]
- Picturesque Canada.** With 600 Original Illustrations. Two Vols. £6 6s.
- Picturesque Europe.** Complete in Five Vols. Each containing 13 Exquisite Steel Plates, from Original Drawings, and nearly 200 Original Illustrations. Cloth, £21; half-morocco, £31 10s.; morocco gilt, £52 10s. *POPULAR EDITION.* In Five Vols., 18s. each.
- Picturesque Mediterranean, The.** With Magnificent Original Illustrations by the leading Artists of the Day. Complete in Two Vols. £2 2s. each.
- Pigeon Keeper, The Practical.** By LEWIS WRIGHT. Illustrated. 3s. 6d.
- Pigeons, Fulton's Book of.** Edited by LEWIS WRIGHT. Revised, Enlarged and supplemented by the Rev. W. F. LUMLEY. With 50 Full-page Illustrations. *Popular Edition.* In One Vol., 10s. 6d.
- Planet, The Story of Our.** By T. G. BONNEY, D.Sc., LL.D., F.R.S., F.S.A., F.G.S. With Coloured Plates and Maps and about 100 Illustrations. 31s. 6d.
- Pocket Library, Cassell's.** Cloth, 1s. 4d. each.
- A King's Diary. By PERCY WHITE.
- A White Boy. By JAMES WELSH.
- The Little Huguenot. By MAX PEMBERTON.
- A Whirl Asunder. By GERTRUDE ATHERTON.

*Selections from Cassell & Company's Publications.*

- Hispaniola Plate (1683-1893). By JOHN BLOUNDELLE-BURTON. 6s.  
Historic Houses of the United Kingdom. Profusely Illustrated. 10s. 6d.  
History, A Foot-note to. Eight Years of Trouble in Samoa. By ROBERT LOUIS STEVENSON. 6s.  
Home Life of the Ancient Greeks, The. Translated by ALICE ZIMMERN. Illustrated. *Cheap Edition*. 5s.  
Horse, The Book of the. By SAMUEL SIDNEY. With 17 Full-page Collotype Plates of Celebrated Horses of the Day, and numerous other Illustrations. Cloth, 15s.  
Horses and Dogs. By O. EERELMAN. With Descriptive Text. Translated from the Dutch by CLARA BELL. With Photogravure Frontispiece, 11 Exquisite Collotypes, and several full page and other engravings in the text. 25s. net.  
Houghton, Lord: The Life, Letters, and Friendships of Richard Monckton Milnes, First Lord Houghton. By Sir WEMYSS RID. In Two Vols., with Two Portraits. 32s.  
Household, Cassell's Book of the. Complete in Four Vols. 5s. each. Four Vols. in Two, half-morocco, 25s.  
Hygiene and Public Health. By B. ARTHUR WHITELEGGE, M.D. 7s. 6d.  
Impregnable City, The. By MAX PEMBERTON. 6s.  
India, Cassell's History of. By JAMES GRANT. With about 400 Illustrations. Two Vols., 9s. each. One Vol., 15s.  
Iron Pirate, The. By MAX PEMBERTON. Illustrated. 5s.  
Island Nights' Entertainments. By R. L. STEVENSON. Illustrated. 6s.  
Kennel Guide, The Practical. By DR. GORDON STABLES. 1s.  
Khiva, A Ride to. By COL. FRED BURNABY. *New Edition*. With Portrait and Seven Illustrations. 3s. 6d.  
King George, In the Days of. By COL. PERCY GROVES. 11d. 1s. 6d.  
King's Hussar, A. Edited by HERBERT COMPTON. 6s.  
Ladies' Physician, The. By a London Physician. *Cheap Edition, Revised and Enlarged*. 3s. 6d.  
Lady Biddy Fane, The Admirable. By FRANK BARRETT. *New Edition*. With 12 Full-page Illustrations. 6s.  
Lady's Dressing-room, The. Translated from the French of BARONNESS STAFFE by LADY COLIN CAMPBELL. 3s. 6d.  
Letters, the Highway of, and its Echoes of Famous Footsteps. By THOMAS ARCHER. Illustrated. 10s. 6d.  
Letts's Diaries and other Time-saving Publications published exclusively by CASSELL & COMPANY. (*A list free on application.*)  
'Lisbet's. A Novel. By LESLIE KRITH. 6s.  
List, ye Landsmen! By W. CLARK RUSSELL. 6s.  
Little Minister, The. By J. M. BARRIE. *Illustrated Edition*. 6s.  
Little Squire, The. By Mrs. HENRY DE LA PASTURE. 3s. 6d.  
Lollandlaff Legends, The. By LOUIS LLOLLANDLAF. 1s.; cloth, 2s.  
Lobengula, Three Years With, and Experiences in South Africa. By J. COOPER-CHADWICK. *Cheap Edition*. 2s. 6d.  
Locomotive Engine, The Biography of a. By HENRY FRITH. 3s. 6d.  
Loftus, Lord Augustus, The Diplomatic Reminiscences of. First and Second Series. Two Vols., each with Portrait, 32s. each Series.  
London, Greater. By EDWARD WALFORD. Two Vols. With about 400 Illustrations. 9s. each.  
London, Old and New. Six Vols., each containing about 200 Illustrations and Maps. Cloth, 9s. each.  
Lost on Du Corrig; or, 'Twixt Earth and Ocean. By STANDISH O GRADY. With 8 Full-page Illustrations. 5s.  
Medicine, Manuals for Students of. (*A List forwarded post free.*)  
Modern Europe, A History of. By C. A. FVFFE, M.A. *Cheap Edition in One Volume*, 10s. 6d. Library Edition, Illustrated. 3 Vols., 7s. 6d. each.  
Mount Desolation. An Australian Romance. By W. CARLTON DAWK. *Cheap Edition*. 3s. 6d.

*Selections from Cassell & Company's Publications.*

- Music, Illustrated History of. By EMIL NAUMANN. Edited by the Rev. Sir F. A. GORE OUSELEY, Bart. Illustrated. Two Vols. 3rs. 6d.
- National Library, Cassell's. In 214 Volumes. Paper covers, 3d.; cloth, 6d. (*A Complete List of the Volumes post free on application.*)
- Natural History, Cassell's Concise. By E. PERCEVAL WRIGHT, M.A., M.D., F.L.S. With several Hundred Illustrations. 7s. 6d.
- Natural History, Cassell's New. Edited by Prof. P. MARTIN DUNCAN, M.B., F.R.S., F.G.S. Complete in Six Vols. With about 2,000 Illustrations. Cloth, 9s. each.
- Nature's Wonder Workers. By KATE R. LOVELL. Illustrated. 3s. 6d.
- New England Boyhood, A. By EDWARD E. HALE. 3s. 6d.
- New Zealand, Picturesque. With Preface by Sir W. B. PERCEVAL, K.C.M.G. Illustrated. 6s.
- Nursing for the Home and for the Hospital, A Handbook of. By CATHERINE J. WOOD. *Cheap Edition.* 1s. 6d.; cloth, 2s.
- Nursing of Sick Children, A Handbook for the. By CATHERINE J. WOOD. 2s. 6d.
- Ohio, The New. A Story of East and West. By EDWARD E. HALE. 6s.
- Oil Painting, A Manual of. By the Hon. JOHN COLLIER. 2s. 6d.
- Old Maids and Young. By E. D'ESTERRE KEELING. 6s.
- Old Boy's Yarns, An. By HAROLD AVERY. With 8 Plates. 3s. 6d.
- Our Own Country. Six Vols. With 1,200 Illustrations. 7s. 6d. each.
- Painting, The English School of. *Cheap Edition.* 3s. 6d.
- Painting, Practical Guides to. With Coloured Plates:—
- |                                 |                                     |
|---------------------------------|-------------------------------------|
| MARINE PAINTING. 5s.            | WATER-COLOUR PAINTING. 5s.          |
| ANIMAL PAINTING. 5s.            | NEUTRAL TINT. 5s.                   |
| CHINA PAINTING. 5s.             | SEPIA, in Two Vols., 3s. each; or   |
| FIGURE PAINTING. 7s. 6d.        | in One Vol., 5s.                    |
| ELEMENTARY FLOWER PAINTING. 3s. | FLOWERS, AND HOW TO PAINT THEM. 5s. |
- Paris, Old and New. A Narrative of its History, its People, and its Places. By H. SUTHERLAND EDWARDS. Profusely Illustrated. Complete in Two Vols., 9s. each; or gilt edges, 10s. 6d. each.
- Peoples of the World, The. In Six Vols. By Dr. ROBERT BROWN. Illustrated. 7s. 6d. each.
- Photography for Amateurs. By T. C. HEPWORTH. *Enlarged and Revised Edition.* Illustrated. 1s.; or cloth, 2s. 6d.
- Phrase and Fable, Dr. Brewer's Dictionary of. Giving the Derivation, Source, or Origin of Common Phrases, Allusions, and Words that have a Tale to Tell. *Entirely New and Greatly Enlarged Edition.* 10s. 6d.
- Picturesque America. Complete in Four Vols., with 48 Exquisite Steel Plates and about 800 Original Wood Engravings. £2 2s. each. *Popular Edition*, Vols. I. & II., 18s. each. [the Set.]
- Picturesque Canada. With 600 Original Illustrations. Two Vols. £6 6s.
- Picturesque Europe. Complete in Five Vols. Each containing 13 Exquisite Steel Plates, from Original Drawings, and nearly 200 Original Illustrations. Cloth, £21; half-morocco, £31 10s.; morocco gilt, £52 10s. *POPULAR EDITION.* In Five Vols., 18s. each.
- Picturesque Mediterranean, The. With Magnificent Original Illustrations by the leading Artists of the Day. Complete in Two Vols. £2 2s. each.
- Pigeon Keeper, The Practical. By LEWIS WRIGHT. Illustrated. 3s. 6d.
- Pigeons, Fulton's Book of. Edited by LEWIS WRIGHT. Revised, Enlarged and supplemented by the Rev. W. F. LUMLEY. With 50 Full-page Illustrations. *Popular Edition.* In One Vol., 10s. 6d.
- Planet, The Story of Our. By T. G. BONNEY, D.Sc., LL.D., F.R.S., F.S.A., F.G.S. With Coloured Plates and Maps and about 100 Illustrations. 3rs. 6d.
- Pocket Library, Cassell's. Cloth, 1s. 4d. each.
- A King's Diary. By PERCY WHITE.
- A White Baby. By JAMES WELSH.
- The Little Huguenot. By MAX FENBERTON.
- A Whirl Asunder. By GERTRUDE ATHERTON.

*Selections from Cassell & Company's Publications.*

- Natural History Coloured Wall Sheets, Cassell's New.** 17 Subjects. Size 39 by 31 in. Mounted on rollers and varnished. 3s. each.
- Object Lessons from Nature.** By Prof. L. C. MIALI, F.L.S. Fully Illustrated. *New and Enlarged Edition.* Two Vols., 1s. 6d. each.
- Physiology for Schools.** By A. T. SCHOFIELD, M.D., M.R.C.S., &c. Illustrated. Cloth, 1s. 9d.; Three Parts, paper covers, 5d. each; or cloth limp, 6d. each.
- Poetry Readers, Cassell's New.** Illustrated. 12 Books, 1d. each; or complete in one Vol., cloth, 1s. 6d.
- Popular Educator, Cassell's NEW.** With Revised Text, New Maps, New Coloured Plates, New Type, &c. In 8 Vols., 5s. each; or in Four Vols., half-morocco, 50s. the set.
- Readers, Cassell's "Belle Sauvage."** An entirely New Series. Fully Illustrated. Strongly bound in cloth. (*List on application.*)
- Readers, Cassell's "Higher Class."** (*List on application.*)
- Readers, Cassell's Readable.** Illustrated. (*List on application.*)
- Readers for Infant Schools, Coloured.** Three Books. 4d. each.
- Reader, The Citizen.** By H. O. ARNOLD-FORSTER, M.P. Illustrated. 1s. 6d. Also a *Scottish Edition*, cloth, 1s. 6d.
- Reader, The Temperance.** By Rev. J. DENNIS HIRD. 1s. 6d.
- Readers, Geographical, Cassell's New.** With numerous Illustrations. (*List on application.*)
- Readers, The "Modern School" Geographical.** (*List on application.*)
- Readers, The "Modern School."** Illustrated. (*List on application.*)
- Reckoning, Howard's Art of.** By C. FRUSHER HOWARD. Paper covers, 1s.; cloth, 2s. *New Edition*, 5s.
- Round the Empire.** By G. R. PARKIN. Fully Illustrated. 1s. 6d.
- Science Applied to Work.** By J. A. BOWER. 1s.
- Science of Everyday Life** By J. A. BOWER. Illustrated. 1s.
- Shade from Models, Common Objects, and Casts of Ornament, How to.** By W. E. SPARKES. With 25 Plates by the Author. 3s.
- Shakspeare's Plays for School Use.** 9 Books. Illustrated. 6d. each.
- Spelling, A Complete Manual of.** By J. D. MORELL, LL.D. 1s.
- Technical Manuals, Cassell's.** Illustrated throughout:—  
Handrailing and Staircasing, 3s. 6d.—Bricklayers, Drawing for, 3s.—  
Building Construction, 2s.—Cabinet-Makers, Drawing for, 3s.—  
Carpenters and Joiners, Drawing for, 3s. 6d.—Gothic Stonework, 3s.—  
Linear Drawing and Practical Geometry, 2s.—Linear Drawing and  
Projection. The Two Vols. in One, 3s. 6d.—Machinists and Engineers,  
Drawing for, 4s. 6d.—Metal-Plate Workers, Drawing for, 3s.—Model  
Drawing, 3s.—Orthographical and Isometrical Projection, 2s.—Practical  
Perspective, 3s.—Stonemasons, Drawing for, 3s.—Applied Mechanics,  
by Sir R. S. Ball, LL.D., 2s.—Systematic Drawing and Shading, 2s.
- Technical Educator, Cassell's New.** With Coloured Plates and Engravings. Complete in Six Volumes, 5s. each.
- Technology, Manuals of.** Edited by Prof. AYRTON, F.R.S., and RICHARD WORMELL, D.Sc., M.A. Illustrated throughout:—  
The Dyeing of Textile Fabrics, by Prof. Hummel, 5s.—Watch and  
Clock Making, by D. Glasgow, Vice-President of the British Horological  
Institute, 4s. 6d.—Steel and Iron, by Prof. W. H. Greenwood,  
F.C.S., M.I.C.E., &c., 5s.—Spinning Woollen and Worsted, by W. S.  
B. McLaren, M.P., 4s. 6d.—Design in Textile Fabrics, by T. R. Ashen-  
hurst, 4s. 6d.—Practical Mechanics, by Prof. Perry, M.E., 3s. 6d.—  
Cutting Tools Worked by Hand and Machine, by Prof. Smith, 3s. 6d.
- Things New and Old; or, Stories from English History.** By H. O. ARNOLD-FORSTER, M.P. Fully Illustrated, and strongly bound in Cloth. Standards I. & II., 9d. each; Standard III., 1s.; Standard IV., 1s. 3d.; Standards V., VI., & VII., 1s. 6d. each.
- This World of Ours.** By H. O. ARNOLD-FORSTER, M.P. Illustrated. 3s. 6d.

*Selections from Cassell & Company's Publications.*

- Science Series, The Century.** Consisting of Biographies of Eminent Scientific Men of the present Century. Edited by Sir HENRY ROSCOE, D.C.L., F.R.S. Crown 8vo, 3s. 6d. each.
- John Dalton and the Rise of Modern Chemistry.** By Sir HENRY E. ROSCOE, F.R.S.
- Major Rennell, F.R.S., and the Rise of English Geography.** By CLEMENTS R. MARKHAM, C.B., F.R.S., President of the Royal Geographical Society.
- Justus Von Liebig: His Life and Work.** By W. A. SHENSTONE, F.I.C.
- The Herschels and Modern Astronomy.** By MISS AGNES M. CLERKE.
- Charles Lyell: His Life and Work.** By Professor T. G. BONNEY, F.R.S.
- Science for All.** Edited by Dr. ROBERT BROWN. Five Vols. 9s. each.
- Scotland, Picturesque and Traditional.** A Pilgrimage with Staff and Knapsack. By G. E. EYRE-TODD. 6s.
- Sea, The Story of the.** An Entirely New and Original Work. Edited by Q. Illustrated. Vol. I. 9s.
- Sea Wolves, The.** By MAX PEMBERTON. Illustrated. 6s.
- Shadow of a Song, The.** A Novel. By CECIL HARLEY. 5s.
- Shaftesbury, The Seventh Earl of, K.G., The Life and Work of.** By EDWIN HODDER. *Cheap Edition.* 3s. 6d.
- Shakespeare, The Plays of.** Edited by Professor HENRY MORLEY. Complete in Thirteen Vols., cloth, 21s.; half-morocco, cloth sides, 42s.
- Shakespeare, Cassell's Quarto Edition.** Containing about 600 Illustrations by H. C. SELOUS. Complete in Three Vols., cloth gilt, £3 3s.
- Shakespeare, The England of.** *New Edition.* By E. GOADBY. With Full-page Illustrations. 2s. 6d.
- Shakspeare's Works.** *Édition de Luxe.*
- "King Henry VIII." Illustrated by SIR JAMES LINTON, P.R.I. (*Price on application.*)
- "Othello." Illustrated by FRANK DICKSEE, R.A. £3 10s.
- "King Henry IV." Illustrated by EDUARD GRÜTZNER. £3 10s.
- "As You Like It." Illustrated by ÉMILE BAYARD. £3 10s.
- Shakspeare, The Leopold.** With 400 Illustrations. *Cheap Edition.* 3s. 6d. Cloth gilt, gilt edges, 5s.; Roxburgh, 7s. 6d.
- Shakspeare, The Royal.** With Steel Plates and Wood Engravings. Three Vols. 15s. each.
- Sketches, The Art of Making and Using.** From the French of G. FRAIPONT. By CLARA BELL. With 50 Illustrations. 2s. 6d.
- Smuggling Days and Smuggling Ways.** By Commander the Hon. HENRY N. SHORE, R.N. With numerous Illustrations. 7s. 6d.
- Social England.** A Record of the Progress of the People. By various writers. Edited by H. D. TRAILL, D.C.L. Vols. I., II., & III., 15s. each. Vol. IV., 17s.
- Social Welfare, Subjects of.** By Rt. Hon. LORD PLAYFAIR, K.C.B. 7s. 6d.
- Sports and Pastimes, Cassell's Complete Book of.** *Cheap Edition.* With more than 900 Illustrations. Medium 8vo, 992 pages, cloth, 3s. 6d.
- Squire, The.** By Mrs. PARR. *Popular Edition.* 6s.
- Standish of High Acre, The.** A Novel. By GILBERT SHELDON. Two Vols. 21s.
- Star-Land.** By Sir R. S. BALL, LL.D., &c. Illustrated. 6s.
- Statesmen, Past and Future.** 6s.
- Story of Francis Cludde, The.** By STANLEY J. WEYMAN. 6s.
- Story Poems.** For Young and Old. Edited by E. DAVENPORT. 3s. 6d.
- Sun, The.** By Sir ROBERT STAWELL BALL, LL.D., F.R.S., F.R.A.S. With Eight Coloured Plates and other Illustrations. 21s.
- Sunshine Series, Cassell's.** 1s. each.
- (*A List of the Volumes post free on application.*)
- Tales of the West.** By EYRE CROWE, A.R.A. Ill. 10s. 6d.
- The "Treasure Island" Series.** *Illustrated Edition.* 3s. 6d. each.
- Treasure Island.** By ROBERT LOUIS STEVENSON. **The Black Arrow.** By ROBERT LOUIS STEVENSON.
- The Master of Ballantrae.** By ROBERT LOUIS STEVENSON. **King Solomon's Mines.** By H. RIDER HAGGARD.

*Selections from Cassell & Company's Publications.*

- Things I have Seen and People I have Known. By G. A. SALA. With Portrait and Autograph. 2 Vols. 21s.
- Tidal Thames, The. By GRANT ALLEN. With India Proof Impressions of Twenty magnificent Full-page Photogravure Plates, and with many other Illustrations in the Text after Original Drawings by W. L. WYLLIE, A.R.A. Half morocco. £5 15s. 6d.
- Tiny Luttrell. By E. W. HORNUNG. *Popular Edition*. 6s.
- To Punish the Czar: a Story of the Crimea. By HORACE HUTCHINSON. Illustrated. 3s. 6d.
- Treatment, The Year-Book of, for 1896. A Critical Review for Practitioners of Medicine and Surgery. *Twelfth Year of Issue*. 7s. 6d.
- Trees, Familiar. By G. S. BOULGER, F.L.S. Two Series. With 40 full-page Coloured Plates by W. H. J. BOOT. 12s. 6d. each.
- Tuxter's Little Maid. By G. B. BURGIN. 6s.
- "Unicod": the Universal Telegraphic Phrase Book. *Desk or Pocket Edition*. 2s. 6d.
- United States, Cassell's History of the. By EDMUND OLLIER. With 600 Illustrations. Three Vols. 9s. each.
- Universal History, Cassell's Illustrated. Four Vols. 9s. each.
- Vision of Saints, A. By Sir LEWIS MORRIS. With 20 Full-page Illustrations. Crown 4to, cloth, 10s. 6d. *Non-illustrated Edition*, 6s.
- Wandering Heath. Short Stories. By Q. 6s.
- War and Peace, Memories and Studies of. By ARCHIBALD FORBES. 16s.
- Westminster Abbey, Annals of. By E. T. BRADLEY (Mrs. A. MURRAY SMITH). Illustrated. With a Preface by Dean BRADLEY. 63s.
- White Shield, The. By BERTRAM MITFORD. 6s.
- Wild Birds, Familiar. By W. SWAYSLAND. Four Series. With 40 Coloured Plates in each. (Sold in sets only; price on application.)
- Wild Flowers, Familiar. By F. E. HULME, F.L.S., F.S.A. Five Series. With 40 Coloured Plates in each. (In sets only; price on application.)
- Wild Flowers Collecting Book. In Six Parts, 4d. each.
- Wild Flowers Drawing and Painting Book. In Six Parts, 4d. each.
- Windsor Castle, The Governor's Guide to. By the Most Noble the MARQUIS OF LORNE, K.T. Profusely Illustrated. Limp Cloth, 1s. Cloth boards, gilt edges, 2s.
- Wit and Humour, Cassell's New World of. With New Pictures and New Text. 6s.
- With Claymore and Bayonet. By Col. PERCY GROVES. Illd. 5s.
- Wood, Rev. J. G., Life of the. By the Rev. THEODORE WOOD. Extra crown 8vo, cloth. *Cheap Edition*. 3s. 6d.
- Work. The Illustrated Weekly Journal for Mechanics. Vol. IX., 4s.
- "Work" Handbooks. Practical Manuals prepared *under the direction* of PAUL N. HASLUCK, Editor of *Work*. Illustrated. 1s. each.
- World Beneath the Waters, A. By Rev. GERARD BANCKS. 3s. 6d.
- World of Wonders. Two Vols. With 400 Illustrations. 7s. 6d. each.
- Wrecker, The. By R. L. STEVENSON and L. OSBOURNE. Illustrated. 6s.
- Yule Tide. Cassell's Christmas Annual. 1s.

---

*ILLUSTRATED MAGAZINES.*

- The Quiver*. Monthly, 6d.
- Cassell's Family Magazine*. Monthly, 6d.
- "*Little Folks*" *Magazine*. Monthly, 6d.
- The Magazine of Art*. Monthly, 1s. 4d.
- "*Chums*." Illustrated Paper for Boys. Weekly, 1d.; Monthly, 6d.
- Cassell's Saturday Journal*. Weekly, 1d.; Monthly, 6d.
- Work*. Weekly, 1d.; Monthly, 6d.
- Cottage Gardening*. Weekly, ½d.; Monthly, 3d.
- CASELL & COMPANY, LIMITED, Ludgate Hill, London.

*Selections from Cassell & Company's Publications.*

**Cassell's Shilling Story Books.** All Illustrated, and containing Interesting Stories.

Bunty and the Boys.  
The Heir of Elmdale.  
The Mystery at Shoncliff School.  
Claimed at Last, & Roy's Reward.  
Thorns and Tangles.  
The Cuckoo in the Robin's Nest.  
John's Mistake. [Pitchers.  
The History of Five Little  
Diamonds in the Sand.  
Surly Bob.

The Giant's Cradle.  
Shag and Doll.  
Aunt Lucia's Locket.  
The Magic Mirror.  
The Cost of Revenge.  
Clever Frank.  
Among the Redskins.  
The Ferryman of Brill.  
Harry Maxwell.  
A Banished Monarch.  
Seventeen Cats.

"Wanted—a King" Series. *Cheap Edition.* Illustrated. 2s. 6d. each.

Great Grandmamma. By Georgina M. Synge.  
Robin's Ride. By Ellinor Davenport Adams.  
Wanted—a King; or, How Merle set the Nursery Rhymes to Rights.  
By Maggie Brown. With Original Designs by Harry Furniss.  
Fairy Tales in Other Lands. By Julia Goddard.

**The World's Workers.** A Series of New and Original Volumes. With Portraits printed on a tint as Frontispiece. 1s. each.

John Cassell. By G. Holden Pike.  
Charles Haddon Spurgeon. By G. Holden Pike.  
Dr. Arnold of Rugby. By Rose E. Selfe.  
The Earl of Shaftesbury. By Henry Frith.  
Sarah Robinson, Agnes Weston, and Mrs. Meredith. By E. M. Tomkinson.  
Thomas A. Edison and Samuel F. B. Morse. By Dr. Denslow and J. Marsh Parker.  
Mrs. Somerville and Mary Carpenter. By Phyllis Browne.  
General Gordon. By the Rev. S. A. Swaine.  
Charles Dickens. By his Eldest Daughter.  
Sir Titus Salt and George Moore. By J. Burnley.

Florence Nightingale, Catherine Marsh, Frances Ridley Havergal, Mrs. Ranyard ("L. N. R."), By Lizzie Aldridge.  
Dr. Guthrie, Father Mathew, Elihu Burritt, George Livesey. By John W. Kirtan, LL.D.  
Sir Henry Havelock and Colin Campbell Lord Clyde. By E. C. Phillips.  
Abraham Lincoln. By Ernest Foster, George Müller and Andrew Reed. By E. R. Pitman.  
Richard Cobden. By R. Gowing.  
Benjamin Franklin. By E. M. Tomkinson.  
Handel. By Eliza Clarke. [Swaine.  
Turner the Artist. By the Rev. S. A. George and Robert Stephenson. By C. L. Matéaux.  
David Livingstone. By Robert Smiles.

\* \* *The above Works can also be had Three in One Vol., cloth, gilt edges, 3s.*

**Library of Wonders.** Illustrated Gift-books for Boys. Paper, 1s.; cloth, 1s. 6d.

Wonderful Balloon Ascents.  
Wonderful Adventures.  
Wonderful Escapes.

Wonders of Animal Instinct.  
Wonders of Bodily Strength and Skill.

**Cassell's Eighteenpenny Story Books.** Illustrated.

Wee Willie Winkie.  
Ups and Downs of a Donkey's Life.  
Three Wee Ulster Lassies.  
Up the Ladder.  
Dick's Hero; and other Stories.  
The Chip Boy.  
Raggles, Raggles, and the Emperor.  
Roses from Thorns.

Faith's Father.  
By Land and Sea.  
The Young Berringtons.  
Jeff and Left.  
Tom Morris's Error.  
Worth more than Gold.  
"Through Flood—Through Fire," and other Stories.  
The Girl with the Golden Locks.  
Stories of the Olden Time.

**Gift Books for Young People.** Original Illustrations in each. Cloth gilt, 1s. 6d. each.

The Boy Hunters of Kentucky. By Edward S. Ellis.  
Red Feather: a Tale of the American Frontier. By Edward S. Ellis.  
Seeking a City.  
Rhoda's Reward; or, "If Wishes were Horses."  
Jack Marston's Anchor.  
Frank's Life-Battle; or, The Three Friends.  
Fritters. By Sarah Pitt.  
The Two Hardcastles. By Madeline Bonavia Hunt.

By Popular Authors. With Four  
Major Monk's Motto. By the Rev. F. Langbridge.  
Trixy. By Maggie Symington.  
Rags and Rainbows: A Story of Thanksgiving.  
Uncle William's Charges; or, The Broken Trust.  
Pretty Pink's Purpose; or, The Little Street Merchants.  
Tim Thomson's Trial. By George Weatherly.  
Ursula's Stumbling-Block. By Julia Goddard.  
Ruth's Life-Work. By the Rev. Joseph Johnson.

*Selections from Cassell & Company's Publications.*

- Holy Land and the Bible, The. By the Rev. C. GRIKIE, D.D., LL.D. (Edin.). Two Vols., 24s. *Illustrated Edition*, One Vol., 21s.
- Life of Christ, The. By the Very Rev. Dean FARRAR, D.D., F.R.S. LIBRARY EDITION. Two Vols. Cloth, 24s.; morocco, 42s. CHEAP ILLUSTRATED EDITION. Cloth, 7s. 6d.; cloth, full gilt, gilt edges, 10s. 6d. POPULAR EDITION (*Revised and Enlarged*), 8vo, cloth, gilt edges, 7s. 6d.; Persian morocco, gilt edges, 10s. 6d.; tree-calf, 15s.
- Moses and Geology; or, The Harmony of the Bible with Science. By the Rev. SAMUEL KINNS, Ph.D., F.R.A.S. Illustrated. *New Edition*. 10s. 6d.
- My Last Will and Testament. By HYACINTHE LOYSON (Père Hyacinthe). Translated by FABIAN WARE. 1s.; cloth, 1s. 6d.
- New Light on the Bible and the Holy Land. By B. T. A. EVETTS, M.A. Illustrated. 21s.
- New Testament Commentary for English Readers, The. Edited by Bishop ELLICOTT. In Three Volumes, 21s. each. Vol. I.—The Four Gospels. Vol. II.—The Acts, Romans, Corinthians, Galatians. Vol. III.—The remaining Books of the New Testament.
- New Testament Commentary. Edited by Bishop ELLICOTT. Handy Volume Edition. St. Matthew, 3s. 6d. St. Mark, 3s. St. Luke, 3s. 6d. St. John, 3s. 6d. The Acts of the Apostles, 3s. 6d. Romans, 2s. 6d. Corinthians I. and II., 3s. Galatians, Ephesians, and Philip-  
pians, 3s. Colossians, Thessalonians, and Timothy, 3s. Titus, Philemon, Hebrews, and James, 3s. Peter, Jude, and John, 3s. The Revelation, 3s. An Introduction to the New Testament, 3s. 6d.
- Old Testament Commentary for English Readers, The. Edited by Bishop ELLICOTT. Complete in Five Vols. 21s. each. Vol. I.—Genesis to Numbers. Vol. II.—Deuteronomy to Samuel II. Vol. III.—Kings I. to Esther. Vol. IV.—Job to Isaiah. Vol. V.—Jeremiah to Malachi.
- Old Testament Commentary. Edited by Bishop ELLICOTT. Handy Volume Edition. Genesis, 3s. 6d. Exodus, 3s. Leviticus, 3s. Numbers, 2s. 6d. Deuteronomy, 2s. 6d.
- Plain Introductions to the Books of the Old Testament. Edited by Bishop ELLICOTT. 3s. 6d.
- Plain Introductions to the Books of the New Testament. Edited by Bishop ELLICOTT. 3s. 6d.
- Protestantism, The History of. By the Rev. J. A. WYLIE, LL.D. Containing upwards of 600 Original Illustrations. Three Vols. 9s. each.
- Quiver Yearly Volume, The. With about 600 Original Illustrations. 7s. 6d.
- Religion, The Dictionary of. By the Rev. W. BENHAM, B.D. *Cheap Edition*. 10s. 6d.
- St. George for England; and other Sermons preached to Children. By the Rev. T. TEIGNMOUTH SHORE, M.A., Canon of Worcester. 5s.
- St. Paul, The Life and Work of. By the Very Rev. Dean FARRAR, D.D., F.R.S. LIBRARY EDITION. Two Vols., cloth, 24s.; calf, 42s. ILLUSTRATED EDITION, complete in One Volume, with about 300 Illustrations, £1 1s.; morocco, £2 2s. POPULAR EDITION. One Volume, 8vo, cloth, 6s.; cloth, gilt edges, 7s. 6d.; Persian morocco, 10s. 6d.; tree-calf, 15s.
- Shall We Know One Another in Heaven? By the Rt. Rev. J. C. RYLE, D.D., Bishop of Liverpool. *Cheap Edition*. Paper covers, 6d.
- Searchings in the Silence. By Rev. GEORGE MATHESON, D.D. 3s. 6d.
- "Sunday," Its Origin, History, and Present Obligation. By the Ven. Archdeacon HESSEY, D.C.L. *Fifth Edition*. 7s. 6d.
- Twilight of Life, The. Words of Counsel and Comfort for the Aged. By the Rev. JOHN ELLERTON, M.A. 1s. 6d.



## **Educational Works and Students' Manuals.**

- Agricultural Text-Books, Cassell's.** (The "Downton" Series.) Edited by JOHN WRIGHTSON, Professor of Agriculture. Fully Illustrated, 2s. 6d. each.—Farm Crops. By Prof. WRIGHTSON.—Soils and Manures. By J. M. H. MUNRO, D.Sc. (London), F.I.C., F.C.S.—Live Stock. By Prof. WRIGHTSON.
- Alphabet, Cassell's Pictorial.** 3s. 6d.
- Arithmetics, Cassell's "Belle Sauvage."** By GEORGE RICKS, B.Sc. Lond. With Test Cards. (*List on application.*)
- Atlas, Cassell's Popular.** Containing 24 Coloured Maps. 2s. 6d.
- Book-Keeping.** By THEODORE JONES. For Schools, 2s.; cloth, 3s. For the Million, 2s.; cloth, 3s. Books for Jones's System, 2s.
- British Empire Map of the World.** By G. R. PARKIN and J. G. BARTHOLOMEW, F.R.G.S. 25s.
- Chemistry, The Public School.** By J. H. ANDERSON, M.A. 2s. 6d.
- Cookery for Schools.** By LIZZIE HERITAGE. 6d.
- Dulce Domum.** Rhymes and Songs for Children. Edited by JOHN FARMER, Editor of "Gaudeamus," &c. Old Notation and Words, 5s. N.B.—The words of the Songs in "Dulce Domum" (with the Airs both in Tonic Sol-fa and Old Notation) can be had in Two Parts, 6d. each.
- Euclid, Cassell's.** Edited by Prof. WALLACE, M.A. 1s.
- Euclid, The First Four Books of.** *New Edition.* In paper, 6d.; cloth, 9d.
- Experimental Geometry.** By PAUL BERT. Illustrated. 1s. 6d.
- French, Cassell's Lessons in.** *New and Revised Edition.* Parts I. and II., each 2s. 6d.; complete, 4s. 6d. Key, 1s. 6d.
- French-English and English-French Dictionary.** *Entirely New and Enlarged Edition.* Cloth, 3s. 6d.; superior binding, 5s.
- French Reader, Cassell's Public School.** By G. S. CONRAD. 2s. 6d.
- Gaudeamus.** Songs for Colleges and Schools. Edited by JOHN FARMER. 5s. Words only, paper covers, 6d.; cloth, 9d.
- German Dictionary, Cassell's New** (German-English, English-German). *Cheap Edition.* Cloth, 3s. 6d. *Superior Binding,* 5s.
- Hand and Eye Training.** By G. RICKS, B.Sc. 2 Vols., with 16 Coloured Plates in each Vol. Cr. 4to, 6s. each. Cards for Class Use, 5 sets, 1s. each.
- Hand and Eye Training.** By GEORGE RICKS, B.Sc., and JOSEPH VAUGHAN. Illustrated. Vol. I. Designing with Coloured Papers. Vol. II. Cardboard Work. 2s. each. Vol. III. Colour Work and Design, 3s.
- Historical Cartoons, Cassell's Coloured.** Size 45 in. x 35 in., 2s. each. Mounted on canvas and varnished, with rollers, 5s. each.
- Italian Lessons, with Exercises, Cassell's.** Cloth, 3s. 6d.
- Latin Dictionary, Cassell's New.** (Latin-English and English-Latin.) Revised by J. R. V. MARCHANT, M.A., and J. F. CHARLES, B.A. Cloth, 3s. 6d. *Superior Binding,* 5s.
- Latin Primer, The First.** By Prof. POSTGATE. 1s.
- Latin Primer, The New.** By Prof. J. P. POSTGATE. 2s. 6d.
- Latin Prose for Lower Forms.** By M. A. BAYFIELD, M.A. 2s. 6d.
- Laws of Every-Day Life.** By H. O. ARNOLD-FORSTER, M.P. 1s. 6d. *Special Edition* on Green Paper for Persons with Weak Eyesight. 2s.
- Lessons in Our Laws; or, Talks at Broadacre Farm.** By H. F. LESTER, B.A. Parts I. and II., 1s. 6d. each.
- Little Folks' History of England.** Illustrated. 1s. 6d.
- Making of the Home, The.** By Mrs. SAMUEL A. BARNETT. 1s. 6d.
- Marlborough Books:**—Arithmetic Examples, 3s. French Exercises, 3s. 6d. French Grammar, 2s. 6d. German Grammar, 3s. 6d.
- Mechanics and Machine Design, Numerical Examples in Practical.** By R. G. BLAINE, M.E. *New Edition, Revised and Enlarged.* With 79 Illustrations. Cloth, 2s. 6d.
- Mechanics for Young Beginners, A First Book of.** By the Rev. J. G. EASTON, M.A. 4s. 6d.

*Selections from Cassell & Company's Publications.*

"Peeps Abroad" Library. *Cheap Editions.* Gilt edges, 2s. 6d. each.

**Rambles Round London.** By C. L. Matéaux. Illustrated.  
**Around and About Old England.** By C. L. Matéaux. Illustrated.  
**Paws and Claws.** By one of the Authors of "Poems written for a Child." Illustrated.  
**Decisive Events in History.** By Thomas Archer. With Original Illustrations.  
**The True Robinson Crusoe.** Cloth gilt.

**Peeps Abroad for Folks at Home.** Illustrated throughout.  
**Wild Adventures in Wild Places.** By Dr. Gordon Stables, R.N. Illustrated.  
**Modern Explorers.** By Thomas Frost. Illustrated. *New and Cheaper Edition.*  
**Early Explorers.** By Thomas Frost.  
**Home Chat with our Young Folks.** Illustrated throughout.  
**Jungle, Peak, and Plain.** Illustrated throughout.

The "Cross and Crown" Series. Illustrated. 2s. 6d. each.

**Freedom's Sword: A Story of the Days of Wallace and Bruce.** By Annie S. Swan.  
**Strong to Suffer: A Story of the Jews.** By E. Wynne.  
**Heroes of the Indian Empire; or, Stories of Valour and Victory.** By Ernest Foster.  
**In Letters of Flame: A Story of the Waldenses.** By C. L. Matéaux.

**Through Trial to Triumph.** By Madeline B. Hunt.  
**By Fire and Sword: A Story of the Huguenots.** By Thomas Archer.  
**Adam Hepburn's Vow: A Tale of Kirk and Covenant.** By Annie S. Swan.  
**No. XIII.; or, The Story of the Lost Vestal.** A Tale of Early Christian Days. By Emma Marshall.

"Golden Mottoes" Series, The. Each Book containing 208 pages, with Four full-page Original Illustrations. Crown 8vo, cloth gilt, 2s. each.

"Nil Desperandum." By the Rev. F. Langbridge, M.A.  
**"Bear and Forbear."** By Sarah Pitt.  
**"Foremost if I Can."** By Helen Ateridge.

"Honour is my Guide." By Jeanie Hering (Mrs. Adams-Acton).  
**"Aim at a Sure End."** By Emily Searchfield.  
**"He Conquers who Endures."** By the Author of "May Cunningham's Trial," &c.

Cassell's Picture Story Books. Each containing about Sixty Pages of Pictures and Stories, &c. 6d. each.

**Little Talks.**  
**Bright Stars.**  
**Nursery Toys.**  
**Pet's Posy.**  
**Tiny Tales.**

**Daisy's Story Book.**  
**Dot's Story Book.**  
**A Nest of Stories.**  
**Good-Night Stories.**  
**Chats for Small Chatterers.**

**Auntie's Stories.**  
**Birdie's Story Book.**  
**Little Chimes.**  
**A Sheaf of Tales.**  
**Dewdrop Stories.**

Illustrated Books for the Little Ones. Containing interesting Stories. All Illustrated. 1s. each; cloth gilt, 1s. 6d.

**Bright Tales & Funny Pictures.**  
**Merry Little Tales.**  
**Little Tales for Little People.**  
**Little People and Their Pets.**  
**Tales Told for Sunday.**  
**Sunday Stories for Small People.**  
**Stories and Pictures for Sunday.**  
**Bible Pictures for Boys and Girls.**  
**Firelight Stories.**  
**Sunlight and Shade.**  
**Kub-a-Dub Tales.**  
**Fine Feathers and Fluffy Fur.**  
**Scrambles and Scrapes.**  
**Tittle Tattle Tales.**

**Up and Down the Garden.**  
**All Sorts of Adventures.**  
**Our Sunday Stories.**  
**Our Holiday Hours.**  
**Indoors and Out.**  
**Some Farm Friends.**  
**Wandering Ways.**  
**Dumb Friends.**  
**Those Golden Sands.**  
**Little Mothers & their Children.**  
**Our Pretty Pets.**  
**Our Schoolday Hours.**  
**Creatures Tame.**  
**Creatures Wild.**

*Selections from Cassell & Company's Publications.*

**Cassell's Shilling Story Books.** All Illustrated, and containing Interest  
ing Stories.

Bunty and the Boys.  
The Heir of Elmdale.  
The Mystery at Shoncliff School.  
Claimed at Last, & Roy's Reward.  
Thorns and Tangles.  
The Cuckoo in the Robin's Nest.  
John's Mistake. [Pitchers.  
The History of Five Little  
Diamonds in the Sand.  
Surly Bob.

The Giant's Cradle.  
Shag and Doll.  
Aunt Lucia's Locket.  
The Magic Mirror.  
The Cost of Revenge.  
Clever Frank.  
Among the Redskins.  
The Ferryman of Brill.  
Harry Maxwell.  
A Banished Monarch.  
Seventeen Cats.

"Wanted—a King" Series. *Cheap Edition.* Illustrated. 2s. 6d. each.  
Great Grandmamma. By Georgina M. Syngé.

Robin's Ride. By Ellinor Davenport Adams.

Wanted—a King; or, How Merle set the Nursery Rhymes to Rights.  
By Maggie Brown. With Original Designs by Harry Furniss.

Fairy Tales in Other Lands. By Julia Goddard.

**The World's Workers.** A Series of New and Original Volumes.

With Portraits printed on a tint as Frontispiece. 1s. each.

John Cassell. By G. Holden Pike.  
Charles Haddon Spurgeon. By  
G. Holden Pike.

Florence Nightingale, Catherine  
Marsh, Frances Ridley Havcr-  
gal, Mrs. Ranyard ("L. N. R.").  
By Lizzie Aldridge.

Dr. Arnold of Rugby. By Rose  
E. Selfe.

Dr. Guthrie, Father Mathew,  
Elihu Burritt, George Livesey.  
By John W. Kirton, L.L.D.

The Earl of Shaftesbury. By  
Henry Frith.

Sarah Robinson, Agnes West-  
on, and Mrs. Meredith. By  
E. M. Tomkinson.

Sir Henry Havelock and Colin  
Campbell Lord Clyde. By E. C.  
Phillips.

Thomas A. Edison and Samuel  
F. B. Morse. By Dr. Denslow  
and J. Marsh Parker.

Abraham Lincoln. By Ernest Foster.  
George Müller and Andrew Reed.  
By E. R. Pitman.

Mrs. Somerville and Mary Car-  
penter. By Phyllis Browne.

Richard Cobden. By R. Gowing.  
Benjamin Franklin. By E. M.  
Tomkinson.

General Gordon. By the Rev.  
S. A. Swaine.

Handel. By Eliza Clarke. [Swaine.  
Turner the Artist. By the Rev. S. A.  
George and Robert Stephenson.  
By C. L. Matfaux.

Charles Dickens. By his Eldest  
Daughter.

Sir Titus Salt and George  
Moore. By J. Burnley.

David Livingstone. By Robert Smiles.

\* \* The above Works can also be had Three in One Vol., cloth, gilt edges, 3s.

**Library of Wonders.** Illustrated Gift-books for Boys. Paper, 1s.;  
cloth, 1s. 6d.

Wonderful Balloon Ascents.

Wonderful Adventures.

Wonderful Escapes.

Wonders of Animal Instinct.

Wonders of Bodily Strength  
and Skill.

**Cassell's Eighteenpenny Story Books.** Illustrated.

Wee Willie Winkie.

Ups and Downs of a Donkey's  
Life.

Three Wee Ulster Lassies.

Up the Ladder.

Dick's Hero; and other Stories.

The Chip Boy.

Raggles, Baggles, and the  
Emperor.

Roses from Thorns.

**Gift Books for Young People.**

Original Illustrations in each.

The Boy Hunters of Kentucky.

By Edward S. Ellis.

Red Feather: a Tale of the  
American Frontier. By

Edward S. Ellis.

Seeking a City.

Rhoda's Reward; or, "If  
Wishes were Horses."

Jack Marston's Anchor.

Frank's Life-Battle; or, The  
Three Friends.

Fritters. By Sarah Pitt.

The Two Hardeastles. By Made-  
line Bonavia Hunt

Faith's Father.

By Land and Sea.

The Young Berringtons.

Jeff and Lef.

Tom Morris's Error.

Worth more than Gold.

"Through Flood—Through Fire;"  
and other Stories.

The Girl with the Golden Locks.

Stories of the Olden Times.

By Popular Authors. With Four

Cloth gilt, 1s. 6d. each.

Major Monk's Motto. By the Rev.  
F. Langbridge.

Trixy. By Maggie Symington.

Rags and Rainbows: A Story of  
Thanksgiving.

Uncle William's Charges; or, The  
Broken Trust.

Pretty Pink's Purpose; or, The  
Little Street Merchants.

Tim Thomson's Trial. By George  
Weatherly.

Ursula's Stumbling-Block. By Julia  
Goddard.

Ruth's Life-Work. By the Rev.  
Joseph Johnson.

*Selections from Cassell & Company's Publications.*

**Cassell's Two-Shilling Story Books. Illustrated.**

**Margaret's Enemy.**  
**Stories of the Tower.**  
**Mr. Burke's Nieces.**  
**May Cunningham's Trial.**  
**The Top of the Ladder: How to Reach it.**  
**Little Flotsam.**  
**Madge and Her Friends.**  
**The Children of the Court.**  
**Maid Marjory.**

**Peggy, and other Tales.**  
**The Four Cats of the Tippetons.**  
**Marion's Two Homes.**  
**Little Folks' Sunday Book.**  
**Two Fourpenny Bits.**  
**Poor Nelly.**  
**Tom Heriot.**  
**Through Peril to Fortune.**  
**Aunt Tabitha's Waifs.**  
**In Mischief Again.**

**Cheap Editions of Popular Volumes for Young People. Bound in cloth, gilt edges, 2s. 6d. each.**

**In Quest of Gold; or, Under the Whanga Falls.**

**On Board the *Esmeralda*; or, Martin Leigh's Log.**

**For Queen and King.**  
**Esther West.**  
**Three Homes.**  
**Working to Win.**  
**Perils Afloat and Brigands Ashore.**

**Books by Edward S. Ellis. Illustrated. Cloth, 2s. 6d. each.**

**The Great Cattle Trail.**  
**The Path in the Ravine.**  
**The Young Renchers.**  
**The Hunters of the Ozark.**  
**The Camp in the Mountains.**  
**Ned in the Woods. A Tale of Early Days in the West.**  
**Down the Mississippi.**  
**The Last War Trail.**  
**Ned on the River. A Tale of Indian River Warfare.**

**Footprints in the Forest.**  
**Up the Tapajos.**  
**Ned in the Block House. A Story of Pioneer Life in Kentucky.**  
**The Lost Trail.**  
**Camp-Fire and Wigwam.**  
**Lost in the Wilds.**  
**Lost in Samoa. A Tale of Adventure in the Navigator Islands.**  
**Tad; or, "Getting Even" with Him.**

**The "World in Pictures." Illustrated throughout. *Cheap Edition.* 1s. 6d. each.**

**A Ramble Round France.**  
**All the Russias.**  
**Chats about Germany.**  
**The Eastern Wonderland (Japan).**

**The Land of Pyramids (Egypt).**

**Glimpses of South America.**  
**Round Africa.**  
**The Land of Temples (India).**  
**The Isles of the Pacific.**  
**Peeps into China**

**Half-Crown Story Books.**

**Pictures of School Life and Boyhood.**

**Pen's Perplexities.**  
**At the South Pole.**

**Books for the Little Ones.**

**Rhymes for the Young Folk.**  
**By William Allingham. Beautifully Illustrated. 3s. 6d.**  
**The History Scrap Book: With nearly 1,000 Engravings. Cloth, 7s. 6d.**

**The Sunday Scrap Book. With Several Hundred Illustrations. Paper boards, 3s. 6d.; cloth, gilt edges, 5s.**  
**The Old Fairy Tales. With Original Illustrations. Boards, 1s.; cloth, 1s. 6d.**

**Albums for Children. 3s. 6d. each.**

**The Album for Home, School, and Play. Containing Stories by Popular Authors. Illustrated.**  
**My Own Album of Animals. With Full-page Illustrations.**

**Picture Album of All Sorts. With Full-page Illustrations.**  
**The Chit-Chat Album. Illustrated throughout.**

**Cassell & Company's Complete Catalogue will be sent post free on application to**

**CASELL & COMPANY, LIMITED, Ludgate Hill, London.**

4 271 271