



This is a digital copy of a book that was preserved for generations on library shelves before it was carefully scanned by Google as part of a project to make the world's books discoverable online.

It has survived long enough for the copyright to expire and the book to enter the public domain. A public domain book is one that was never subject to copyright or whose legal copyright term has expired. Whether a book is in the public domain may vary country to country. Public domain books are our gateways to the past, representing a wealth of history, culture and knowledge that's often difficult to discover.

Marks, notations and other marginalia present in the original volume will appear in this file - a reminder of this book's long journey from the publisher to a library and finally to you.

Usage guidelines

Google is proud to partner with libraries to digitize public domain materials and make them widely accessible. Public domain books belong to the public and we are merely their custodians. Nevertheless, this work is expensive, so in order to keep providing this resource, we have taken steps to prevent abuse by commercial parties, including placing technical restrictions on automated querying.

We also ask that you:

- + *Make non-commercial use of the files* We designed Google Book Search for use by individuals, and we request that you use these files for personal, non-commercial purposes.
- + *Refrain from automated querying* Do not send automated queries of any sort to Google's system: If you are conducting research on machine translation, optical character recognition or other areas where access to a large amount of text is helpful, please contact us. We encourage the use of public domain materials for these purposes and may be able to help.
- + *Maintain attribution* The Google "watermark" you see on each file is essential for informing people about this project and helping them find additional materials through Google Book Search. Please do not remove it.
- + *Keep it legal* Whatever your use, remember that you are responsible for ensuring that what you are doing is legal. Do not assume that just because we believe a book is in the public domain for users in the United States, that the work is also in the public domain for users in other countries. Whether a book is still in copyright varies from country to country, and we can't offer guidance on whether any specific use of any specific book is allowed. Please do not assume that a book's appearance in Google Book Search means it can be used in any manner anywhere in the world. Copyright infringement liability can be quite severe.

About Google Book Search

Google's mission is to organize the world's information and to make it universally accessible and useful. Google Book Search helps readers discover the world's books while helping authors and publishers reach new audiences. You can search through the full text of this book on the web at <http://books.google.com/>

How to Use Wood-Working Tools

EducT

6718

81.460



GINN, HEATH & Co.

Educ. T 6718, 81.460



Harvard College Library

FROM

The estate of:
Robert Treat Paine

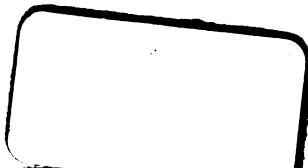



3 2044 102 873 528

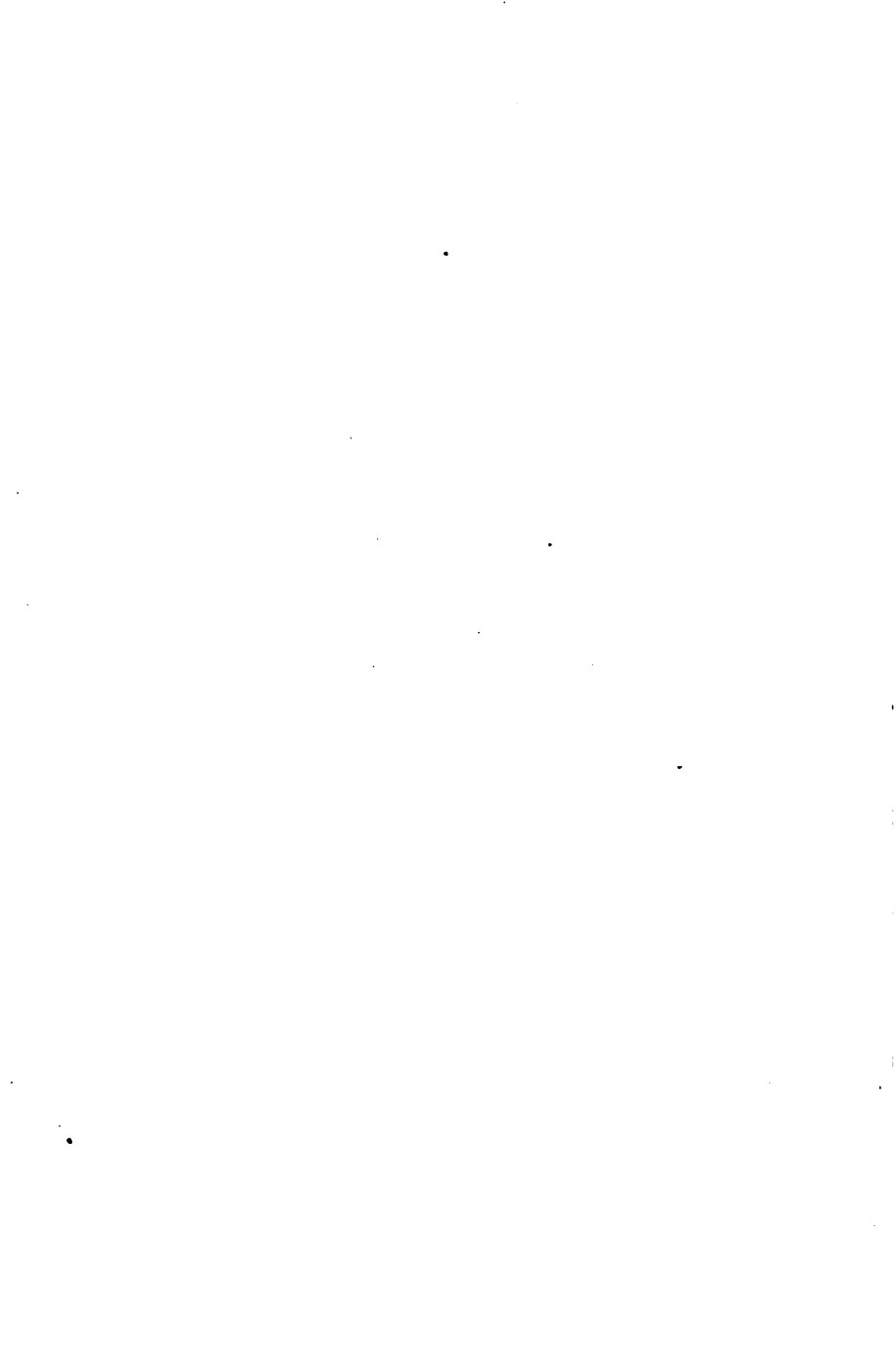

©

WOOD-WORKING TOOLS;

HOW TO USE THEM.

A
MANUAL.

“When a man teaches his son no trade, it is as if he taught him highway robbery.”—TALMUD.

BOSTON:
PUBLISHED BY GINN & HEATH
FOR THE INDUSTRIAL SCHOOL ASSOCIATION.

1881.

E. S. T. 6-113, 10, 4, 60
Educ-2475-10-

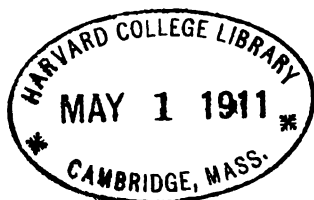

For the school
...

COPYRIGHTED BY
HENRY S. GREW, TREASURER.
1881.

GINN & HEATH:
J. S. CUSHING, PRINTER, 16 HAWLEY STREET,
BOSTON.

INTRODUCTION.

THIS book aims to give, in fourteen chapters, directions and exercises for the use of the Wood-working Tools. Like other text-books of its kind, it will best accomplish its purpose in the hands of an intelligent and practical teacher, who may use it for his own guidance in conducting a class. At the same time, it is so simply written and so amply illustrated, that any bright boy will find the book alone a great help in his endeavors to learn the right way of using common tools.

The book has been prepared for the Industrial School Association of Boston. That Society, having conducted successful industrial schools during the winters of 1876-7 and 1877-8, at 23 Church Street, concluded to offer its apparatus and the results of its experiments to the city, in the hope that such schools would be maintained at the public expense. Meantime, the Society appointed a committee to embody the valuable experience gained in its schools, in a Manual of Instruction.

This Manual, with the accompanying account of its preparation, is their report.

The Society hopes that the public will share its satisfaction in the work of its committee. The lessons are few in number, and simple in character. They aim only to give an elementary training in the manipulations common to all wood-working trades. But it is not chiefly in the interest of these or of any other trades that this course is offered to the public. Lessons like these, given at the same time

with the studies now pursued in our grammar schools, would relieve the weariness of purely mental exercises, and give a new zest to their pursuit. A single ward-room, like the one used by the school in Church Street, in any city, for the six months from December to May, during which time it usually lies idle, with very little expense beyond the original plant and a moderate salary to the teacher, would meet all the needs of three or four of the largest grammar schools for boys. Three such supplementary schools, if used in turn, would amply satisfy all the rightful claims of industrial education of this kind upon the school system of such a city as Boston. At so small an outlay of attention and money might the native aptitude of American youth for manual skill be turned into useful channels. In so simple a way might the needed check be given to that exclusive tendency towards clerical rather than industrial pursuits which the present school course undoubtedly promotes.

GEORGE LEONARD CHANEY,

*President of the
Industrial School Association.*

Applicants for further information may address Miss S. C. PAINE, Secretary, Brimmer Street, Boston; and Rev. GEO. L. CHANEY, 7 Tremont Place, Boston, Mass.

REPORT.

THE committee charged with the duty of preparing for the association a Manual of Wood-working Tools beg to present their final Report.

This committee at first attempted to prepare a course of lessons which, though sufficiently simple to meet the needs of such schools as the association desired to encourage, should cover the whole ground to be gone over, in detail, the association authorizing the employment of such clerical and other assistance as might be necessary.

In its present form, the work, though somewhat less extensive than was at first proposed, is believed to be sufficiently full for the youngest pupils who are competent to understand the principles involved, and have strength enough to perform the work. At the same time pains has been taken, while systematizing the whole scheme, to leave the teacher free to adopt such alternative exercises as may promise best to develop the active intelligence of the student. To this end, while a number of the exercises, sufficient thoroughly to exemplify the method employed, have been worked out in detail, many of the lessons have been given only in outline, so far as the text is concerned, though with full illustration, and in some merely the subjects are indicated.

A series of lessons was prepared in the winter of 1877-78 by Mr. Channing Whitaker and Mr. Raymond D. Chapell. They had the advantage of the valuable advice and suggestions of Mr. Alonzo W. Folsom, who critically examined the

work in its various stages of preparation. Each brought a special experience to bear upon the undertaking. Holtzapffel's well-known treatise* proved itself to be an invaluable aid.

The first draft of these lessons was printed or papyrographed, and used by Mr. Chapell during the winter of 1877-78, while he was acting as teacher both in the school maintained by the association in Church Street, and in the School of Mechanic Arts of the Massachusetts Institute of Technology. Many valuable results of the experience derived from their use were embodied in a revised copy. A broadside containing the first lesson was printed for general distribution as an illustration of the work which the association had undertaken, and attracted much attention. It was afterwards printed in "The Polytechnic Review," of Philadelphia, and in the Report of the Massachusetts State Board of Education for 1876-77. During that winter a collateral experience was gained in other similar schools of which Mr. Whitaker had the direction. The lessons also were placed in the hands of Mr. C. H. Dow, who taught a school of this kind in Gloucester, Mass., in 1878-79, from whom valuable suggestions were afterward received.

During the fall and winter of 1878, Mr. George H. Chapman, a graduate of the Institute of Technology, devoted himself with zeal and efficiency to the writing out of new lessons based upon the instructions which he received of Mr. George Smith, Instructor in the School of Mechanic Arts. He repeated in his own workshop the exercises of the school, and

* The preparation of a series of lessons, suited to the use of amateurs and others, was undertaken by Mr. Charles Holtzapffel, of London, as early as 1835, but he finally abandoned the scheme after years of labor, on account of difficulties of classification and arrangement. He used the material that he had accumulated as the basis of his admirable scientific treatise upon "Turning and Mechanical Manipulation," one-half of which was published in 1850.

wrote out day by day a statement of the exact line of procedure which it was found necessary to adopt in order to perform them most satisfactorily. He had shown himself to be peculiarly fitted for making such investigations as these, and although in frail health his interest did not abate with his strength, but he continued his labors almost up to the moment of his untimely death, which occurred in January, 1879. During the same season, Mr. R. L. Bridgman took an active part in the work, and aided in making a digest and revision of much of the manuscript and printed matter that had thus far been brought together.

It now became evident that so explicit and complete a work as was at first contemplated would occupy too much time in preparation, and, when done, might be too large and too costly to meet the ends that the association had chiefly in view. It was therefore decided to put into form for the press such a portion of the manuscript as would form a text-book sufficiently full for the guidance of classes, but not entering so thoroughly into matters of detail as was at first intended. The text in its present form is the result of that decision.

The illustrations in which the figure of the workman occurs have been prepared by Mr. D. T. Kendrick. They are intended to make plain to the pupils all of those minute details of position which the pupils need to understand without at the same time burdening their attention with extremely-detailed instructions in print. It was found to be necessary to pose the model for the artist in order that he might understand clearly what he was to represent, and it was only by the intervention of photography that it became practicable to secure the advantages to be derived from adopting this course. Mr. Frank Rowell, a member of the committee, and the superintendent of the different schools that have been conducted by the society, allowed his photographic gallery to

be used for this purpose, and both Mr. Whitaker and Mr. Folsom gave their personal attention to the accurate posing of the model in the most illustrative position for his work, and to placing the camera in the best position from which to view the model. The engravings which accompany the text were obtained from Mr. Kendrick's drawings, the outlines of which were traced from the photographs. The other engravings are reproductions of perspective drawings by Mr. A. J. Boyden, architect, a graduate of the Institute, who in this and in other ways rendered valuable assistance. Mr. Henry W. Burton and Mr. Albert Snow furnished suggestions that are embodied in the work. Messrs. A. J. Wilkinson & Co. allowed themselves to be frequently troubled with questions concerning wood-working tools, and gave free access to their large collection for the purpose of forwarding the work of the association.

The illustrations, arranged in proper order, with a manuscript text, were now placed in the hands of Mr. J. Phillips White, who taught several classes in Cambridge during the winter of 1879-80. Mr. White took great interest in the work, and throughout a considerable portion of the term made weekly reports to the committee of the practical workings of the scheme, and wrote out notes of each lesson day by day. His experience seems to show that an intelligent class, in the hands of a competent instructor, can go through this manual in twenty-five or thirty lessons, of two hours each.

Fully to explain the fundamental principles of the science of wood-working, and to embody all the valuable results of the experience which has been gained, would make a large volume, an undertaking that the association has virtually begun, but which, as has been said, their committee have had neither the leisure nor the means to prosecute. Although the present volume is thus but a fragment of the whole, it is

nevertheless believed to be sufficiently complete for the objects they have immediately in view, and to be adapted to the needs of classes of young persons who, with the tools in their hands, shall study under the leadership of intelligent and discreet persons, who are at the same time skilful teachers and expert workmen.

The suggestion that the society should prepare a manual to aid in promoting the efficiency of the instruction given, and that the plan of the manual should be substantially that which has been partially carried out in this text, originated with Mr. Whitaker, who, subject to the approval of the committee, directed and supervised the work of those employed by the society. Throughout the undertaking he has had the benefit of the aid and advice of the other members of the committee. Many meetings, both of the committee and of the society, have been held, at which questions that relate to the text-book have been discussed. Members of the society have in these meetings made suggestions which have been of service to the committee in the prosecution of the work. Finally, the text in its present form has been critically read and approved by Mr. Folsom.

For the committee,

WILLIAM R. WARE,

Chairman.

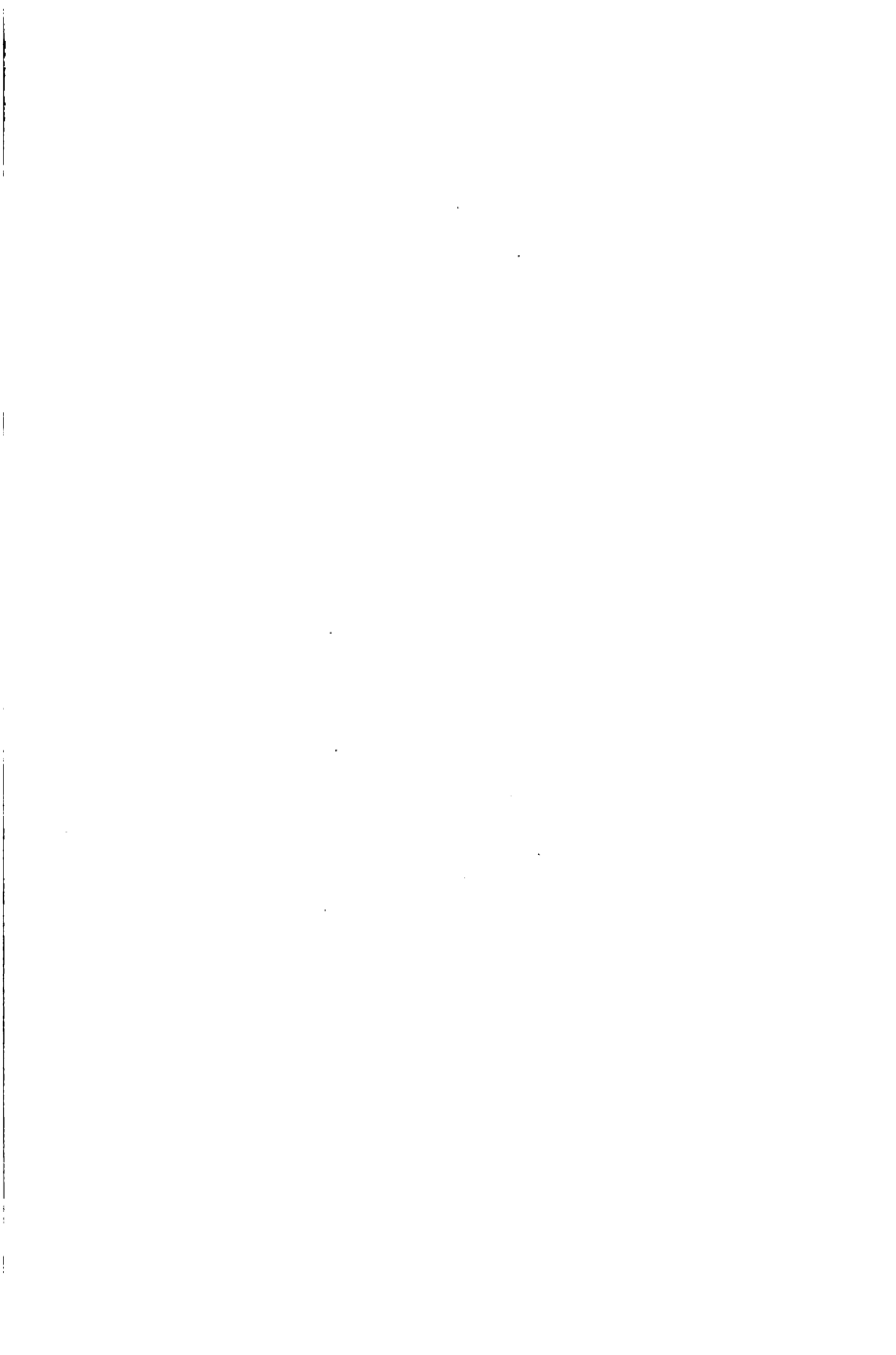

CONTENTS.



| | PAGE. |
|---|-------|
| CHAPTER I. STRIKING | 7 |
| II. SPLITTING | 14 |
| III. CUTTING | 22 |
| IV. PLANING | 27 |
| V. SHARPENING | 33 |
| VI. ADJUSTING THE PLANE-IRON | 39 |
| VII. MARKING AND LINING | 44 |
| VIII. SCORING AND PARING | 58 |
| IX. SAWING | 63 |
| X. REDUCING WARPED TO PLANE SURFACES | 69 |
| XI. PRODUCING PLANE SURFACES THAT ARE SQUARE WITH EACH OTHER | 72 |
| XII. BORING | 75 |
| XIII. JOINERY | 77 |
| XIV. FINISHING | 102 |

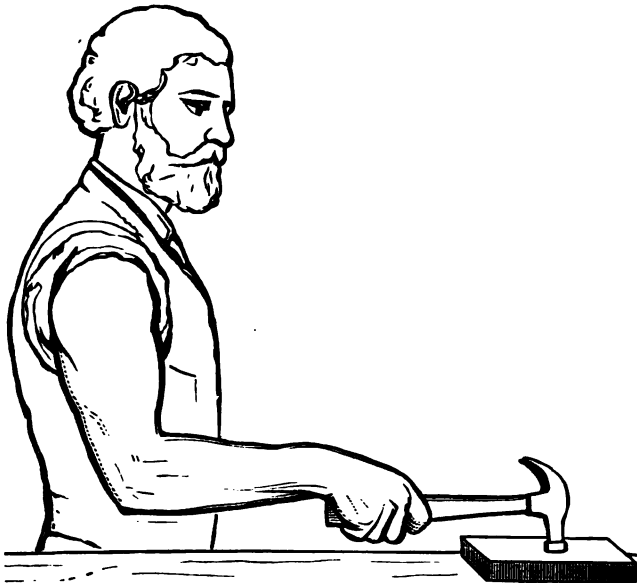

Fig. I, a.

POSITION BEFORE BEGINNING TO SWING THE TOOL.

WOOD-WORKING TOOLS.—HOW TO USE THEM.



CHAPTER I.

STRIKING.

THERE is a large class of *striking tools*. It includes the hammer, the mallet, the beetle, the hatchet, the axe, the adze, and all other tools which act by blows. *Three movements* are practised in striking with the *lighter* tools. They are the wrist, the elbow, and the shoulder movements.

In each of the first three exercises, strike a number of blows with the proper tool upon a soft-wood board, or block, or upon a pad; repeating the exercise until the nature of each movement is well understood, and fixed in the memory.

The wrist movement is suited to the use of tack-hammers, and other *light* tools with which taps are struck.

EXERCISE I, 1. — *The wrist movement.* Grasp the handle of a light tool as far from its head as is convenient, with the thumb extended along the handle, and the fingers closed upon it. Let the face of the tool rest upon the object to be struck, as in Fig. I, *a*. Strike *light taps*, moving the hand and the tool as if they were one stiff piece, swinging about the wrist-joint as about a fixed centre. (See Fig. I, *b*.) *Vary the height* to which the head of the tool is lifted by varying the extent of the motion at the wrist-joint, and observe that *such variation will affect the force of the blow.*

Do not at *any* time during the movement relax the grasp of the hand, nor permit any motion of the forearm. If, at first, it be too difficult to prevent the forearm from moving, support it near the elbow. It may rest for support against the body, or upon a block on the bench.

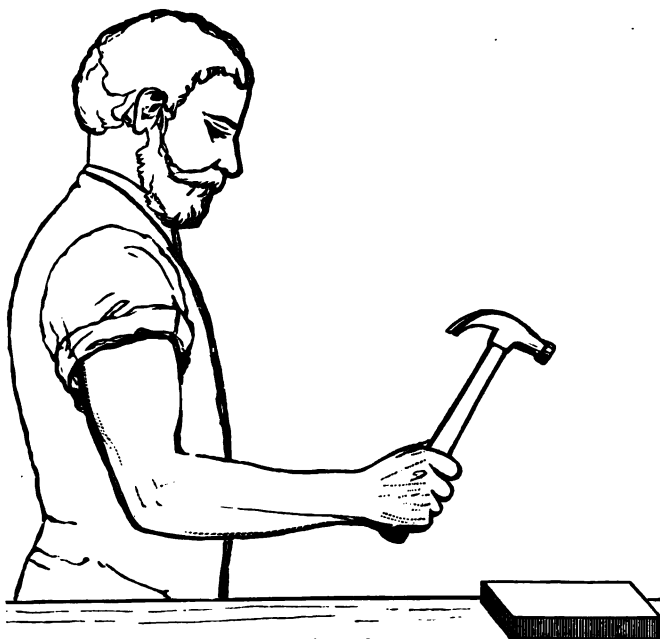

Fig. I, b.

THE WRIST MOVEMENT.

The elbow movement is suited to the use of tools of *light and medium weight*, with which blows of medium intensity are struck.

Ex. I, 2.—*The elbow movement.* Hold the tool, and move the wrist, as in the wrist movement. In addition, *move the forearm* freely about the elbow-joint. (See Fig. I, c.)

Do not permit *any* movement of the arm above the elbow. *Vary the extent* of the movement at *both* the wrist and the elbow-joints, thus modifying the force of the blows. If, at first, it be difficult to prevent a movement of the arm above the elbow, support the arm against the body.



Fig. I, c.

THE ELBOW MOVEMENT.

The shoulder movement is suited to the use of the *heavier* tools with which somewhat heavy blows are struck by one hand.

EX. I, 3. — *The shoulder movement.* Hold the tool, and move the wrist and the elbow, as in the elbow movement. In addition, *move the arm* freely about the shoulder-joint.

(See Fig. I, *d.*) Do not permit *any* movement of the body, except the slight movement at the ankle-joints, that prevents the body from being thrown out of balance by the motion of the hammer.



Fig. I, *d.*

THE SHOULDER MOVEMENT.

The striking tools may be classed *in two principal subdivisions*. Those of the *first subdivision do not act directly* upon the wood ; but they strike a *second* tool or instrument which *does* act upon it. The hammer, the mallet, and the beetle are examples. Those of the *second subdivision do act directly* upon the wood. The hatchet, the axe, and the adze are examples. They are not simply striking tools ; they

may be *splitting*, *cutting*, or *piercing* tools as well. We are concerned with them, in this chapter, only as striking tools. It generally requires more skill to swing with *sufficient* precision the tools of the second subdivision than those of the first.

Ex. I, 4. — *To strike with precision.* Mark a number of points upon the wider flat surfaces, or *side-faces*, as they may be called, of a piece of pine board, and strike them with as great precision as possible. Before beginning to swing the tool, place it upon the body to be struck, in the *exact position* that it should have when the blow occurs. (See Fig. I, a.) Notice the *positions* of the head and handle of the tool, and of the hand, arm, and body of the person. Endeavor

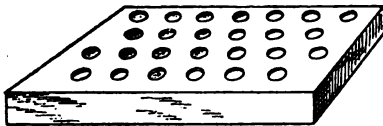

Fig. I, e.

THE EFFECTS OF SQUARE BLOWS.

to bring the tool and all parts of the body into *exactly* the same positions, at the instant when the blow occurs, as they had when the tool was placed in position. A skilful person can tell, *by the feeling* in the different parts of his body, whether they have all come back pretty nearly to their original positions or not. He can also control the tool while it is swinging, so that *all shall* thus come back pretty nearly to their original positions. Strike a number of blows by each of the three movements named before; and *decide* with which it is most easy, and with which it is most difficult, to strike with precision.

Ex. I, 5. — *To strike square blows.* Lay a piece of pine

board upon a firm support. Sink the face of the hammer many times into the surface of the wood. Try to have the centres of the dents about an inch apart, and on lines parallel to the long edges of the wood, as shown in Fig. I, *c*. Both of the side-faces of the board may be covered with dents in

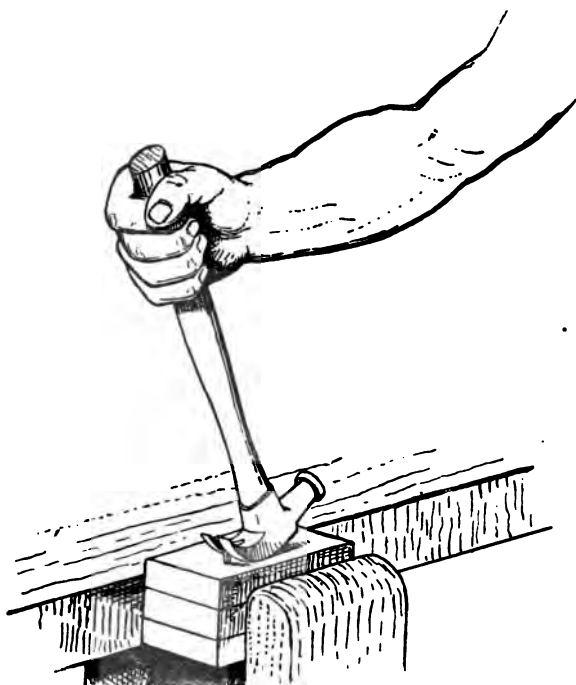

Fig. I, *f*.

WITHDRAWING A NAIL, — FIRST STAGE.

this way. Be very particular to strike *square* blows. The *dent* made by a square blow will have the *same outline* as the face of the hammer, and *all* points of its outline will be *sunken equally deep*.

- EX. I, 6. — *To drive tacks.*
 EX. I, 7. — *To drive small nails.*
 EX. I, 8. — *To drive large nails.*
 EX. I, 9. — *To withdraw nails.*

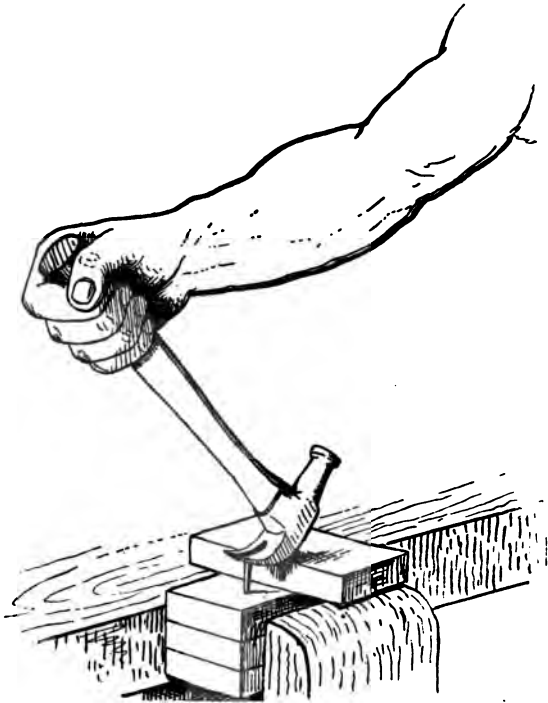

Fig. I, g.

WITHDRAWING A NAIL, — SECOND STAGE.

- EX. I, 10. — *To drive nails horizontally and at the left hand.*
 EX. I, 11. — *To drive nails horizontally and at the right hand.*
 EX. I, 12. — *Toe-nailing.*
 EX. I, 13. — *Blind-nailing.*

CHAPTER II.

SPLITTING.

Caution.—TAKE CARE NOT TO SPLIT TOWARD YOURSELF.

EXERCISE II, 1. — *The end of the grain ; the yearly growth ; the lines of growth ; the pith-rays ; the age of the wood.* Take a *very thin and thoroughly dry* piece of oak, cut squarely off from the end of a stick of cord-wood, and showing the central pith-tube. Examine its flat surfaces. They exhibit what is called the *end* of the grain.

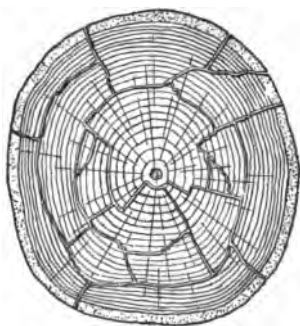

Fig. II, a.

LINES OF EASIEST SEPARATION ON
THE END OF THE GRAIN.

(See Fig. II, a.) Observe the curves which surround the pith-tube, at different distances from it. The distance between any two of these curves indicates the thickness of the layer of new wood, which grows each year between the older wood and the bark. This new wood may be called the *yearly growth*. The lines which separate the growths of succeeding years may be called the

lines of growth. Observe that rays shoot out from the centre in all directions. These rays are formed of a pithy substance, and may be called *pith-rays*. Count the layers of yearly growth, and thus learn how long it took for the wood to grow.

Ex. II, 2. — *Lines of easiest separation on the end of the grain.* Hold the disk in the palm of the left hand, and crush it with the right thumb. Observe that it generally breaks *along the rays*, or along *the lines of growth*, or along *zigzag lines*, which follow sometimes the rays and sometimes, the lines. (See Fig. II, *a.*)

Ex. II, 3. — *Lines of easiest separation along the grain.* Tear into strips a piece of very thin wood, such as a veneer. Notice that the rent *follows* the grain. Examine the end of the grain. It will be found that, generally, the wood has split along the pith-rays, or along the lines of growth.

Ex. II, 4. — *Wood breaks more easily along than across the grain.* Break several of the fragments both lengthwise and crosswise of the grain, and observe *how much more easily* they break lengthwise than crosswise.

Ex. II, 5. — *The edge of the grain.* Take a somewhat wide, thin, pine stick, which has its wider surfaces parallel, or nearly parallel, to the pith-rays, and, therefore, nearly square with the lines of growth. Examine these wider surfaces. They show what is called the *edge* of the grain. The edge of the grain has a brilliant, glistening appearance, when newly split, and is sometimes called "the mirror surface."

Ex. II, 6. — *Cutting with the edge; splitting with the wedge; splitting along the grain.* Force the sharp blade of a knife into the *middle* of the end of the stick used in the last exercise. (See Fig. II, *b.*) Observe that at first the wood separates exactly at the sharp edge of the blade, and that *it is the edge that separates* the wood. When a sharp edge separates a substance, the action is called *cutting*. Notice that before the edge goes far into the wood, the wood tears asunder in advance of it, and the edge ceases to act. The *wedge* becomes now the part of the tool which separates the wood. When a wedge separates a substance, the action is called *splitting*. Notice that the parts of the wood that are on either

side of the blade are about equally stiff. They *bend about equally* to make room for the blade, and the stick splits *along the grain*.

Ex. II, 7. — *Splitting along the grain.* Wood splits more easily along a line of growth than at a small angle with such a line. Split the pieces of the stick used in the last exercise, through the middle, as before, into four, eight, or more pieces. Observe that the wood splits, generally, along the grain. Notice the lines of growth on the ends. They are

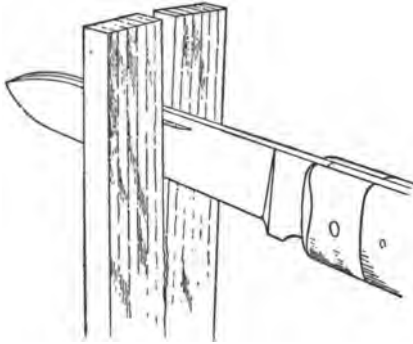

Fig. II, b.

THE EDGE OF THE GRAIN. SPLITTING ALONG
THE GRAIN.

nearly or quite *square with the wider surfaces of the stick*. Start some of the splits more or less *inclined* to the lines of growth. Notice that such splits will of themselves *twist about* until they become nearly or quite parallel to the lines of growth. Notice that the split surfaces are *more beautiful* when parallel to these lines than when slightly inclined to them.

Ex. II, 8. — *The side of the grain.* Take a thin, somewhat wide, pine stick, which has its wider surfaces parallel,

or very nearly parallel, to the lines of growth. Examine these wider surfaces. They show what is called the *side* of the grain. When newly split, the side of the grain has an appearance somewhat like that of satin, as was seen when examining some of the narrow split surfaces produced in Ex. II, 7.

Ex. II, 9. — *Splitting partly across the grain.* Force the blade into the end of the stick used in Ex. II, 8, but very *near* to one edge, as shown in Fig. II, *c*. Notice that the

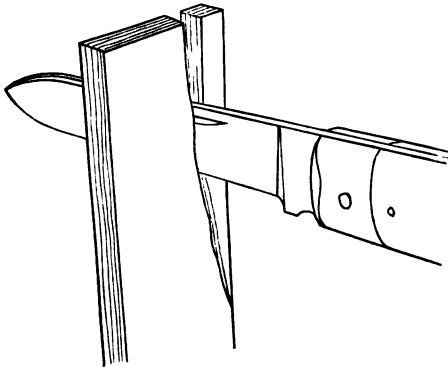

Fig. II, *c*.

THE SIDE OF THE GRAIN. SPLITTING PARTLY
ACROSS THE GRAIN.

part of the stick which is between the blade and the *nearer* edge is very *limber*, while the other part is very *stiff*. It is almost entirely by the bending of the limber part that room is made for the blade to enter the stick. The *inner* edge of the limber part is so much stretched by this bending that it *breaks across the grain*, and the split gradually tears through toward the nearer edge.

Ex. II, 10. — *Splitting partly across the grain.* Wood splits more easily along the pith-rays than at a small angle

with those rays. Split into fragments the pieces of the stick used in Ex. II, 9. Observe that whenever a part split off is *much* more limber than the part from which it was separated, the split *generally* tears through toward the nearer edge. Notice the lines of growth on the ends. The pith-rays are square with the lines of growth; but they are not so strongly marked, as those lines, in pine wood. Start some of the splits a little *out of square* with the lines of growth. They will then start somewhat inclined to the pith-rays. Notice that such splits will of themselves *twist about* until they become nearly or quite square with the lines of growth, and parallel to the pith-rays. Observe that, when the split surfaces are parallel to the pith-rays, they have the *glistening*, mirror-like appearance which has been noticed before.

Ex. II, 11. — *Splitting parallel to the grain and to the lines of growth.* Take a small pine stick, square at its ends, with its length parallel to the grain, and with the lines of growth, at one end, stretching *parallel* to two sides of the stick. Split it with a sharp knife, parallel to the lines of growth, into two nearly equal pieces. Notice how *easily* it splits.

Ex. II, 12. — *Splitting parallel to the grain and to the pith-rays.* Take a stick like that used in Ex. II, 11. Split it square with the lines of growth into two nearly equal pieces. Notice that about the *same* force is required as when splitting parallel to those lines.

Ex. II, 13. — *Splitting parallel to the grain, and across the lines of growth and the pith-rays.* Take a small pine stick, square at its ends, with its length parallel to the grain, and with the lines of growth stretching *from corner to corner* at one end. Split it along a line that is parallel to one side of the stick. This line will be *about equally inclined* to the lines of growth and the pith-rays. Notice that considerably *more force* is required to split diagonally across the lines and

rays than to split parallel to either. Observe that, as the split advances, its surface loses its plane, smooth character, and becomes furrowed or corrugated, as shown in Fig. II, *d*. Examine the surface and the end of the split. Notice that parts of the split surfaces are *twisted*. Near the cut, they are parallel to it. At the other end of the stick, they are more nearly parallel to the lines of growth, or to the pith-rays.

Ex. II, 14. — *Splitting fire-wood; the easy way.* Split a small stick of round fire-wood with a *sharp* hand-axe that

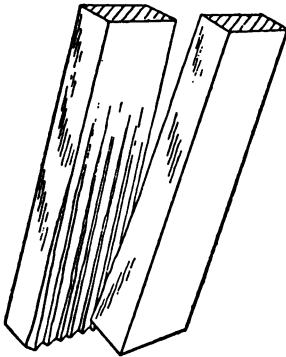
Fig. II, *d*.

MORE DIFFICULT TO SPLIT.

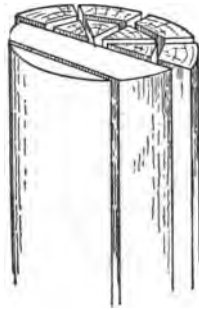
Fig. II, *e*.

THE HARD WAY. THE EASY WAY.

has a *good wedge* to split with. Extend the first split entirely across one end, *through the centre and along the rays*, as shown in Fig. II, *e*. Divide one-half of the stick into quarters and eighths, along the rays. Divide each eighth into two parts along the lines of growth. The wood splits with *comparative ease* at any of *these* sections.

Ex. II, 15. — *Splitting fire-wood; the hard way.* Divide the other half of the stick used in the last exercise into two parts, along a surface parallel to the first split, and at a dis-

tance from it equal to about two-thirds or three-fourths of the distance from the pith to the bark. It will be found *comparatively difficult* to split the wood at this section.

Knots. — Knots split most easily at the surface that contains the central pith-tube of the knot and the main pith-tube of the stick.

In splitting large logs of wood, two feet or more in diameter, it is common to proceed as follows: The wood-cutter stands upon the top of the log, and sinks the edge of the

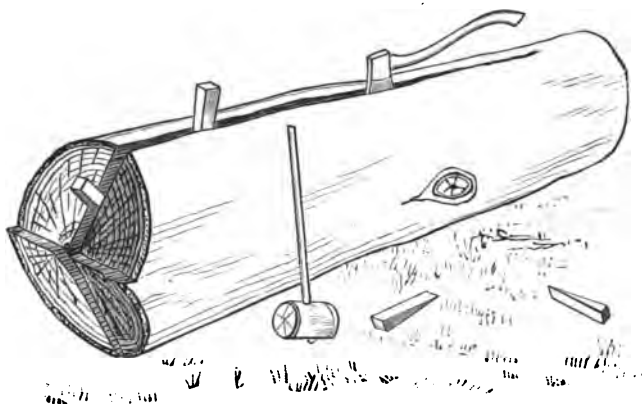

Fig. II, *f*.
LOG-SPLITTING.

axe into its end as many times as is necessary to make a *cut* along one of the pith-rays and extending from the pith-tube to the bark. He then drives one or more large iron *wedges* into the cut, by means of a heavy wooden mallet called a *beetle*. (See Fig. II, *f*.) The head of the beetle is usually made of elm, or of some other wood which splits with difficulty; and both ends of the head are hooped with iron, as a further safeguard against its splitting. Having driven in the wedge or wedges, he extends the cut along the grain, by

sinking his axe through the bark into the sapwood, thus indicating the direction which the split should follow. He now pursues one or the other of two methods, according as the log splits with difficulty or with ease.

First method. — If it splits with difficulty, he rolls the log entirely over, and *repeats* that which he has already done *upon the other side*. That is, he extends the cut entirely across the diameter of the log by the aid of his axe. With the beetle he drives other wedges into the split, and with the axe he extends the cut lengthwise of the log. He proceeds thus, splitting or cutting as his judgment dictates, until the log is divided from end to end.

Second method. — If the log splits easily, the method pursued only differs from that which has just been described in this ; that he *does not roll the log over*, but performs all of his work upon one side.

CHAPTER III.

CUTTING.

Cautions. — NEVER CUT WITH A DULL TOOL. NEVER CUT TOWARD YOURSELF.

When a sharp edge separates a substance, the action is called *cutting*. The knife, the shave, the chisel, the hatchet, the axe, are cutting tools. When a wood-cutting tool is *very sharp*, its edge divides the wood in its path, without either tearing the fibres apart or crushing them. If the edge is dull, it may make its way through the wood, partly by cutting and partly by tearing or crushing, but it will *never* make a *bright, clean cut when dull*. The blade of a cutting-tool is *wedge-shaped*, and grows thicker from the edge towards the back. As it penetrates, it forces the particles that are divided by the edge farther and farther apart.

Cutting without splitting. If the chip or shaving removed is *very thin*, it bends easily out of the way of the tool, and does not check its progress. The shaving is *cut*, not split, from the stick. The shaving *bends so easily that even the fibres of the shaving are not split apart*.

Ex. III, 1. — *Cutting lengthwise without splitting.* With a *very sharp* pocket-knife, cut *lengthwise* of the grain a *very thin* shaving from a piece of soft wood. It will bend out of the way, as in Fig. III, *a*.

Ex. III, 2. — *Cutting crosswise without splitting.* Cut *crosswise* of the grain a *very thin* shaving from the piece of soft wood. It will bend out of the way, as in Fig. III, *b*.

In both exercises, III, 1 and III, 2, the shaving bends so easily out of the way, that the wedge has, practically, no work

to do. The *cutting-edge* removes the shaving without aid from the wedge.

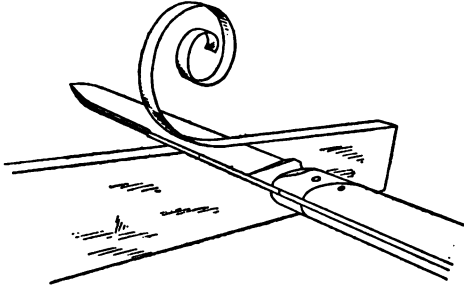

Fig. III, a.

CUTTING LENGTHWISE OF THE GRAIN WITHOUT SPLITTING.

If a chip or shaving is so thick that it does not bend out of the way, when being removed, the *wedge* of the tool *squeezes* the particles of wood that it touches, into the adjoining wood, and by thus compressing it, makes room for

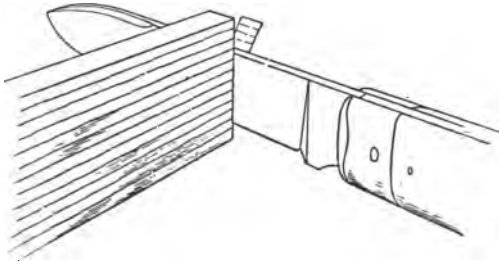

Fig. III, b.

CUTTING CROSSWISE OF THE GRAIN WITHOUT SPLITTING.

itself as it cuts deeper and deeper. When the wood is much compressed, great force is required to compress it, and it would be difficult to cut a *thick* stick in two, in this way.

Ex. III, 3. — *Cutting with compression.* Lay the stick used in Ex. III, 1, upon its side, and force the blade as far as you can into the stick, square across the grain, at a short distance from the end. (See Fig. III, *c.*) Notice that when the blade has been withdrawn, the wood cannot recover its original shape, and a gap is left in it. *This is a true cut, because the cutting-edge divides the wood, but it is cutting combined with compression.* The cut is as easily made in this exercise as in Ex. III, 2. It is the *force required to compress the wood*, by means of the wedge, that makes it so difficult to divide the stick.

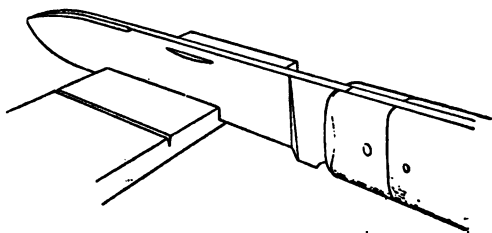

Fig. III, *c.*

CUTTING WITH COMPRESSION.

If wood could be compressed as easily as fruit can, the stick would be as easily divided. If it could recover its shape as easily, it would be as little injured.

Ex. III, 4. — *Cutting with compression.* Drive a sharp mortising chisel far into a *thick* piece of pine with a mallet. Cut *square across* the grain. Notice that *great force* is required to compress the wood, and that the wood cannot recover its shape, after the blade has been withdrawn.

Ex. III, 5. — *To lessen the work of cutting with compression, by causing a thick chip to split.* Cut a *thin* piece of pine, diagonally across the grain, near one end. Begin at about half an inch or an inch from the end, and force the knife

through, making a cut that is *square* with the wider flat surfaces of the wood, as in Fig. III, *d*. The chip will make room for the blade, *by splitting* along the pith-rays, or the lines of growth, for *it requires less force to split the chip* in this way, *than to compress the wood*.

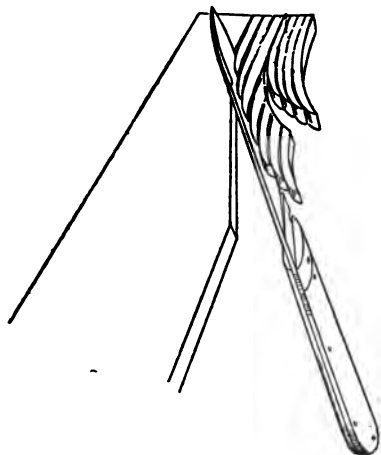

Fig. III, *d*.

THE CHIP SPLITS TO MAKE ROOM FOR THE BLADE.

Ex. III, 6. *To lessen the work of cutting with compression, by taking advantage of the flexibility of the wood.* Cut a *thin* piece of pine, diagonally across the grain, near one end, as in Ex. III, 5, except that the cut should be *inclined about* 45° to the flat surfaces of the wood, as is shown in Fig. III, *e*. The chip is so *flexible* that *very little* pressure is needed to bend it out of the way of the blade.

The very sharpest cutting-edge is notched. — If the sharpest cutting-edge should be examined through a pow-

erful microscope, it would be found to be *notched* all along its length. It is thus *like a saw* with exceedingly minute teeth, and acts to the best advantage, if it is made to *slide in the direction of its length*, while it is being forced through the wood.

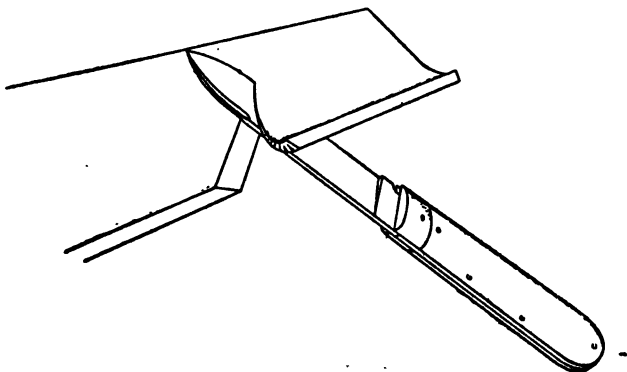

Fig. III, *e*.

THE CHIP BENDS TO MAKE ROOM FOR THE BLADE.

Ex. III, 7. — *To test the advantage of sliding the edge while cutting.* Repeat Ex. III, 1, without sliding the edge while cutting; then repeat it again, sliding the edge in the direction of its length. Notice how much more easily the cut is made, and, also, how much more brilliant the cut surface is, in the latter case. Repeat twice, each of the exercises III, 2-6, in a similar manner and for a similar purpose.

CHAPTER IV.

PLANING.

Cautions. — BRUSH ALL GRIT AND DIRT FROM THE SURFACE BEFORE BEGINNING TO PLANE, AND THUS AVOID DULLING THE IRON. WHEN PUSHING THE PLANE, KEEP ITS SOLE PARALLEL WITH THE SURFACE TO BE FORMED.

EXERCISE IV, 1. — *To remove the saw-marks from a rough, flat board with a jack-plane.* — Stand with the right side of the body at the bench, at the rear end of the board, with the *left foot advanced* in a bracing attitude, and so that the body may move freely, lengthwise of the bench. Grasp the handle of the plane *firmly* in the right hand, with the forefinger extended to touch the plane-iron. (See Fig. IV, *a.*)

To begin the stroke, grasp the stock of the plane, in front of the plane-iron, firmly with the left hand, the left thumb pressing on the left side of the stock, and with the four fingers on the opposite side, nearly at right angles with the sole of the plane. Place the sole of the plane on the left-hand edge of the board, with the plane-iron behind the rear end of the board. Push steadily with the right hand, and *press down with the left hand, so as to keep the toe of the plane flat upon the surface of the board.* This will prevent the plane from tilting endwise, the shaving from being too thick at the start, and the board from being too thin at the rear end. If the shaving *is* too thick at the start, the plane may jump and leave a bunch on the board. When the stroke has extended as far as is convenient, let the left arm drop easily to the side, and continue the stroke with the right hand. (See Fig. IV, *b.*)

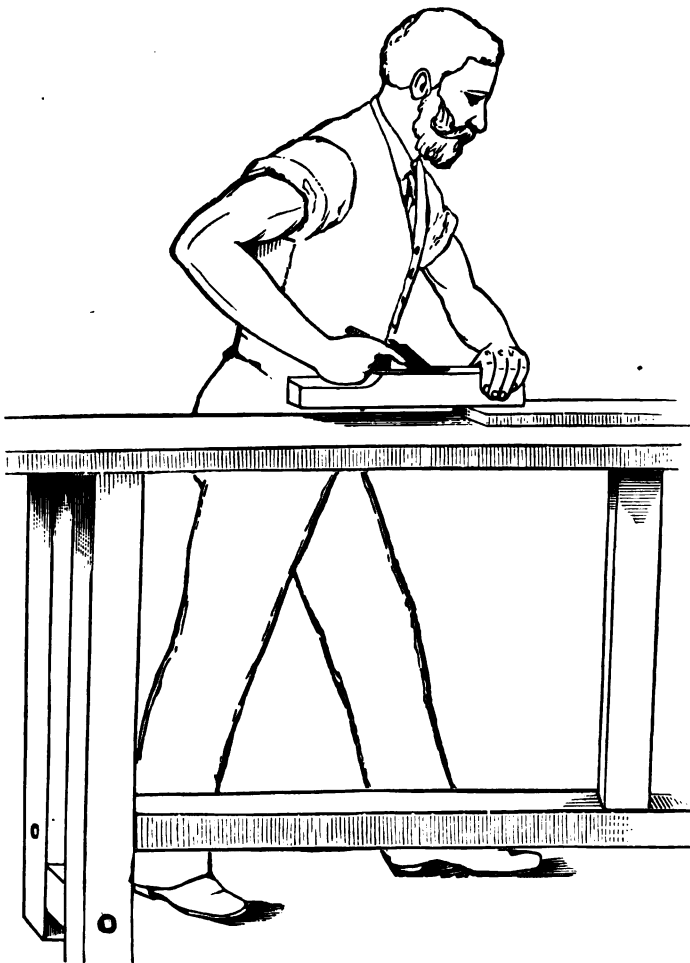

Fig. IV, *a*.

THE TOE IS PRESSED DOWN WITH THE LEFT HAND.

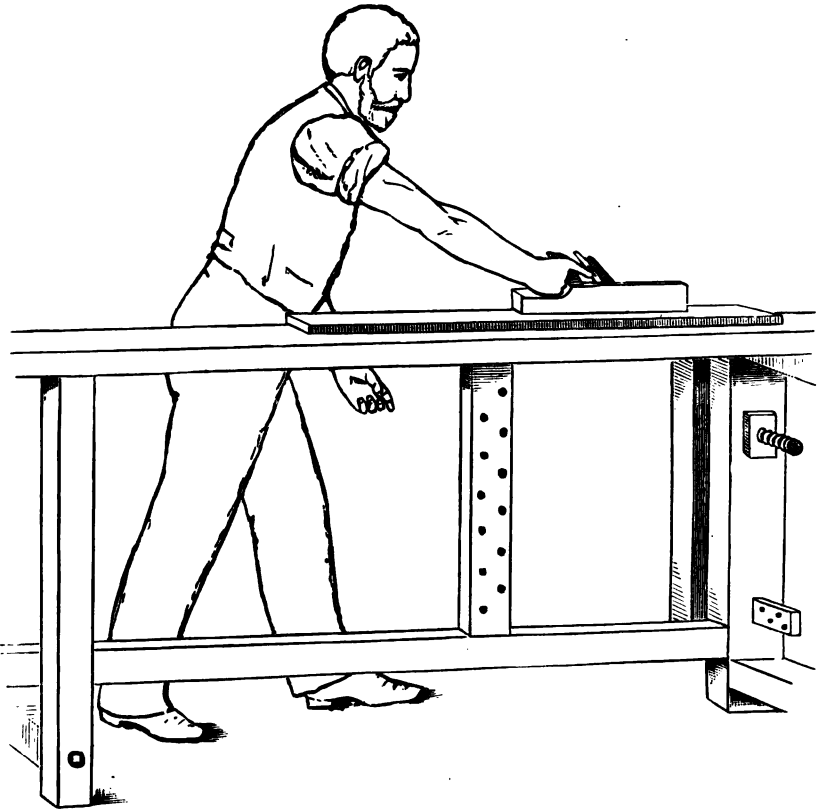

Fig. IV, *b*.

THE LEFT HAND DROPS TO THE SIDE, WHILE THE STROKE IS CONTINUED WITH THE RIGHT. THE HEEL IS KEPT DOWN WITH THE RIGHT HAND.

While returning the plane to the rear end of the board, *tip it upon the left-hand edge of the sole*, in order to *avoid dulling the iron*. (See Fig. IV, *c*.)

When planing near *either edge* of the board (see Fig. IV, *d*), *keep the sole of the plane flat upon the board*. This will prevent the plane from tipping sidewise, the shaving from being too thick and the board from being too thin, at the edges.

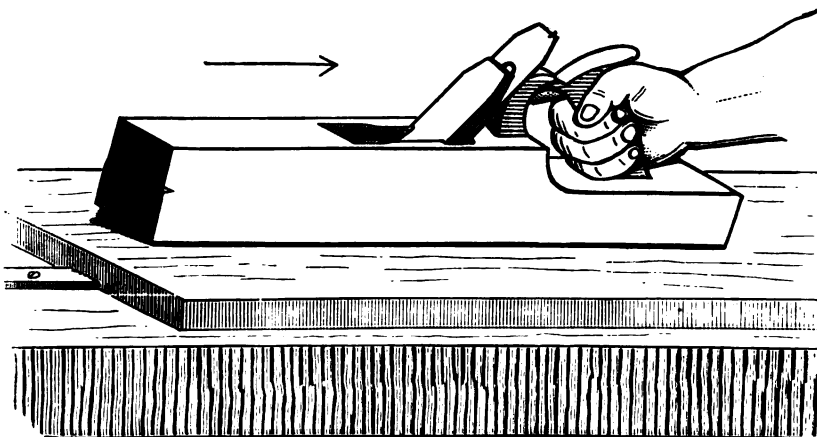

Fig. IV, *c*.

THE PLANE IS TIPPED, TO AVOID DULLING IT.

When planing near the *forward end* of the board, *press down with the right hand*, so as to keep the heel of the plane flat upon the surface of the board until the plane-iron has passed entirely off from it. (See Fig. IV, *b*.) This will prevent the shaving from being too thick and the board from being too thin at the forward end. If the board is longer than a convenient stroke, take each succeeding stroke a little to the right of the last until the right-hand edge has been

reached, then advance the length of the stroke, and proceed as before. Occasionally brush away the shavings, so that the plane may rest flat upon the board.

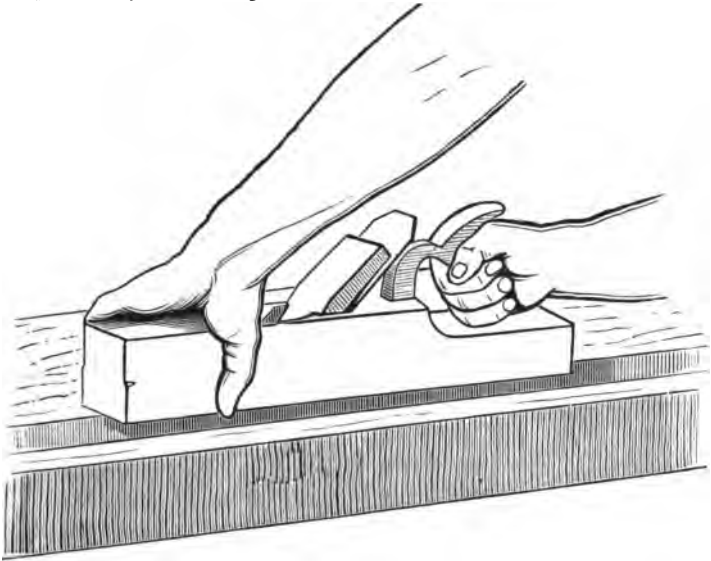

Fig. IV, d.

THE SOLE IS KEPT FLAT ON THE BOARD, WHEN PLANING NEAR THE EDGE.

Ex. IV, 2. — *To test the flatness of a newly-planed surface.* Place either edge of the sole upon the surface, and look *toward the light* between the edge and the surface. (See Fig. IV, c.) Repeat the test at different places along the board. *Sight lengthwise* of the board. *Sight diagonally across* the board.

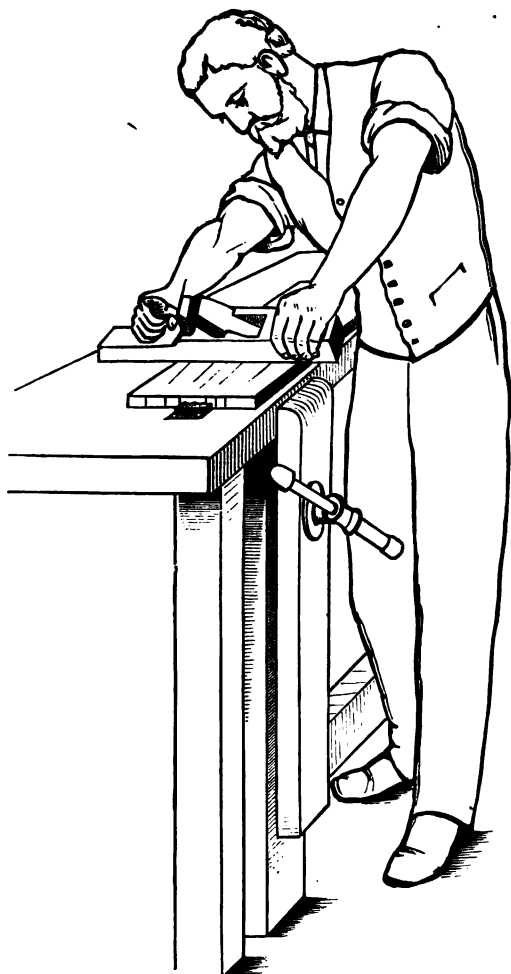

Fig. IV, *e*.

TESTING THE FLATNESS OF THE BOARD.

CHAPTER V.

SHARPENING.

JACK-KNIVES, and some hatchets, are ground upon both sides. Paring chisels and plane-irons are ground upon one side only.

EX. V, 1. — *To sharpen a jack-knife upon an oil-stone.*

EX. V, 2. — *To sharpen a paring-chisel upon an oil-stone.*

EX. V, 3. — *To sharpen a hatchet upon an oil-stone.*

EX. V, 4. — *To withdraw the plane-iron from its position in the stock.* Hold the plane in the left hand, with the thumb in its throat, as shown in Fig. V, *a*. Press against the chip, with the thumb, to prevent the iron and the chip from falling, when they have been loosened. Loosen the iron and the chip, by striking a few light blows upon the toe, as shown in Fig. V, *a*. Withdraw the iron and the chip, with the right hand, and put the iron, the chip, and the stock, upon the bench.

EX. V, 5. — *To sharpen the plane-iron upon an oil-stone.* If the iron has a cap, remove it by the aid of a screw-driver. Then grasp the iron in the right hand, as shown in Fig. V, *b*, with the thumb on its edge, the first two fingers stretched upon its upper side, the last two fingers closed against the under side, and the end pressed against the palm of the hand. Steady the iron, while sharpening it, by pressing the first three fingers of the left hand upon the upper side, and the thumb against the under side, as shown in Fig. V, *c*. Rub the iron over the surface of the oil-stone, in such a manner that the wide, flat surfaces of the iron will remain constantly at an angle of 35° with the upper surface of the oil-stone. (See

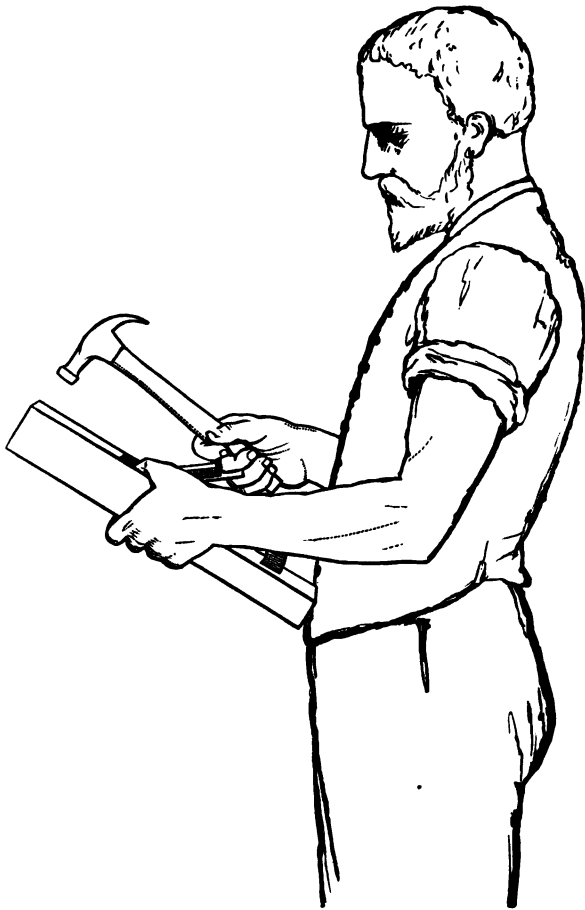

Fig. V, *a*.

WITHDRAWING THE IRON.

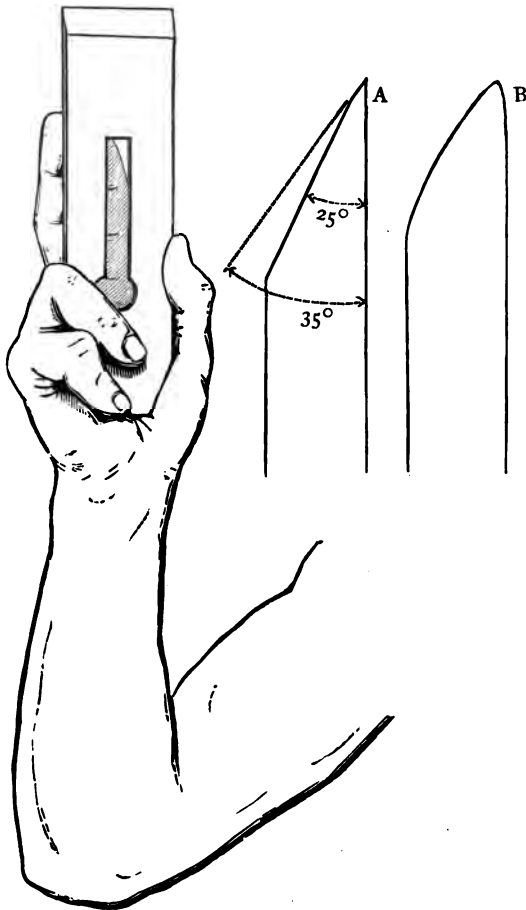

Fig. V, *b*.

THE RIGHT-HAND GRASP.

THE CORRECTLY SHARPENED IRON, AT A.

THE INCORRECTLY SHARPENED IRON, AT B.

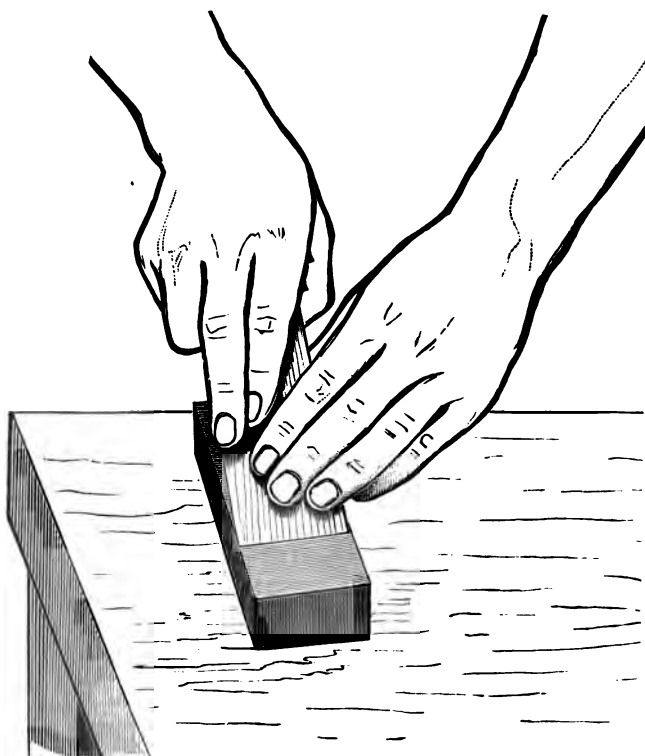

Fig. V, c.

SHARPENING THE IRON.



Fig. V, *d*.

REPLACING THE IRON.

A, Fig. V, *b*.) *Take care not to permit a variation, in the inclination of the iron to the oil-stone, while rubbing, for, if the inclination varies, an objectionable rounded edge will be produced. (See B, Fig. V, b.) If a burr or "wire-edge" forms, turn the iron over and rub it upon the surface of the stone while the iron lies flat upon it.*

Ex. V, 6. — *To replace the iron.* Hold the stock in the left hand, with the thumb in its throat, with the fingers under its sole, and with the tip of the second finger in its mouth. Replace the iron and the chip, press gently upon the chip with the thumb, and insert the iron so far that its cutting-edge may be felt by the tip of the second finger. *Take care not to cut the finger.* Drive the chip in sufficiently far to hold the iron. (See Fig. V, *d*.)

CHAPTER VI.

ADJUSTING THE PLANE-IRON.

THE *principal* adjustment of the plane-iron is for the purpose of determining or changing the thickness of the shaving which it can cut.

EXERCISE VI, 1. — *To determine the thickness of the shaving.* Having replaced the iron, as in Ex. V, 6, sight lengthwise of the sole, to see if the cutting-edge is in the desired position. *If it does not project enough*, strike a light blow, with the hammer, on the opposite end of the iron, as is shown in Fig. VI, *a*. If the *right-hand* portion of the cutting-edge projects, beyond the sole, more than the left-hand portion does, correct the inequality by driving the opposite end of the iron from *right to left*, as is shown in Fig. VI, *b*. If the *left-hand* portion of the cutting edge projects too much, drive the opposite end of the iron from *left to right*, as is shown in Fig. VI, *c*. Notice, that in order to drive the end of the iron from left to right, easily, the heel of the plane should be thrown well toward the right side. If the entire cutting-edge projects too much from the sole, strike one or two light taps on the top of the toe, as is shown in Fig. V, *a*, and afterwards tighten the chip, as in Fig. V, *d*. Finally, sight endwise of the sole, as in Fig. VI, *a*, to see if the iron *is* accurately adjusted.

Ex. VI, 2. — *To test the adjustment of the plane-iron.* Try the plane upon a board or plank, to see if it *will* remove shavings of the desired thickness.



Fig. VI, a.

MAKING THE IRON PROJECT FURTHER.



Fig. VI, *b*.

MAKING THE LEFT-HAND PORTION OF THE EDGE PROJECT.



Fig. VI, c.

MAKING THE RIGHT-HAND PORTION OF THE EDGE PROJECT.

Ex. VI, 3. — *To vary the adjustment so as to produce shavings which differ in thickness.* Repeat Exercises V, 4, V, 6, and VI, 1-2, several times in succession, in the order named, *withdrawing, replacing, and adjusting the iron* to produce shavings which differ in thickness. Finally, *test* the different adjustments by making shavings and examining them.

CHAPTER VII.

MARKING AND LINING.

EXERCISE VII, 1. — *To mark off distances.* Rest the *graduated edge of the rule*, upon the board, parallel to the tried edge, as shown in Fig. VII, *a*. Rest the elbow upon the board, elevate the wrist, hold the rule firmly between the thumb and the middle finger, to prevent it from tipping, and rest the other fingers upon the top of the rule, to keep it steady, as shown. Mark points upon the board, with a pencil, scribe, knife, or other marking tool, where the lines on the rule touch the board.

To make a chalk-mark connecting two points of a surface, the "chalk-line" is used. It is a small, stout cord, upon which chalk has been rubbed. When stretched tightly between the points, and snapped by being raised and let go, it leaves a distinct chalk-mark upon the surface.

Ex. VII, 2. — *To chalk the chalk-line.* Pass the awl through the loop in the end of the line, and thrust it into the wood at one of the points that the mark is to join. Draw the line tight with the left hand, holding it between the thumb and the forefinger, as shown in Fig. VII, *b*. Hold the chalk in the right hand, bend the cord at the chalk, keep the *flat surface* of the chalk *parallel* to the two straight parts of the bent cord; let the cord just touch the inner surface of the thumb. Rub the chalk upon the cord, beginning near the awl. Notice that, when the line and chalk are held as has been directed, the line will *wear away the chalk without wasting it*.

Ex. VII, 3. — *To join two given points of a horizontal board, by a straight chalk-mark.* Pass the awl through the

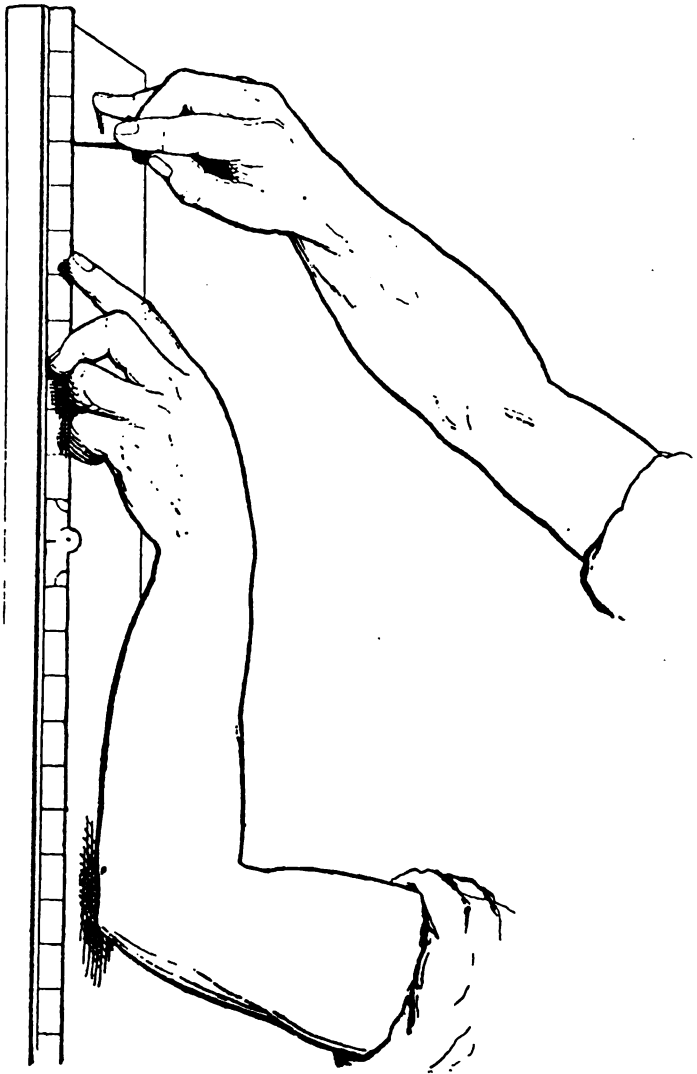
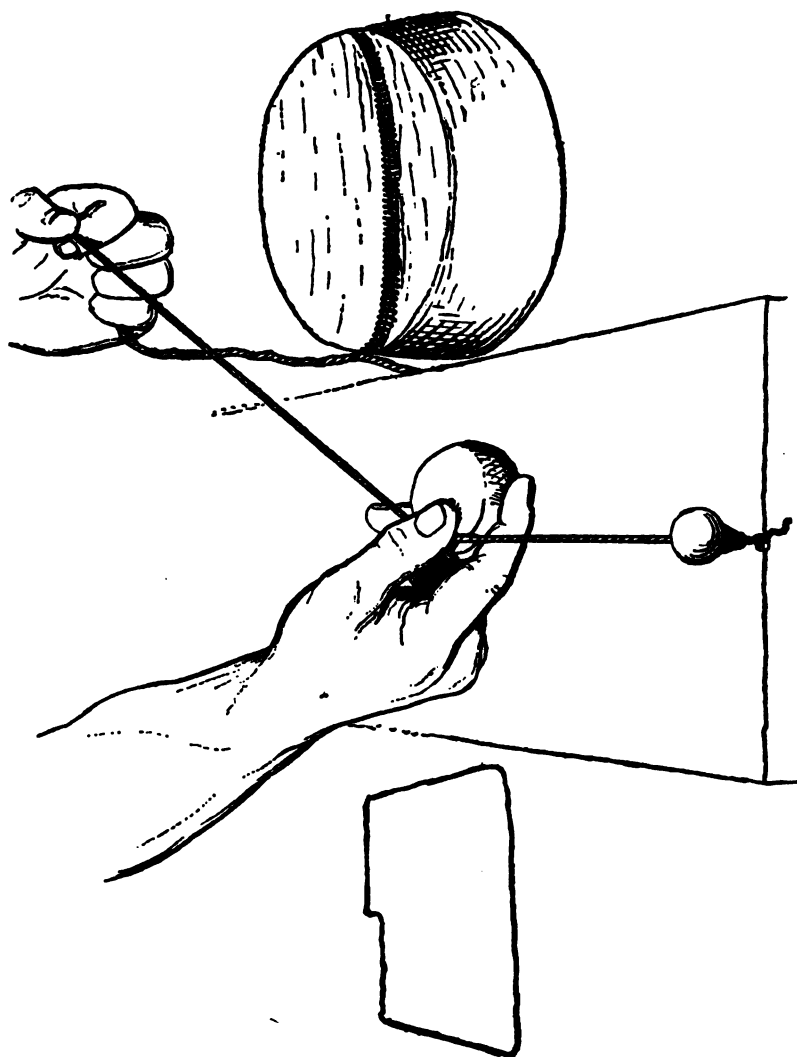

Fig. VII, *a*.

MARKING OFF DISTANCES.

Fig. VII, *b*.

CHALKING THE LINE.

loop in the line, and press it into the wood at one of the given points. Chalk the line. Then stretch it *tightly*, covering the other given point with it. If convenient to do so, stand at the end of the board, with the right foot advanced toward it. With the *left thumb* press the line against the board near its end, and with the fingers of the left hand *draw the line tight*. (See Fig. VII, *c.*) Shut one eye and *place the other directly over the line*. Grasp the line, at a point which is about a foot distant from the left thumb, between the tips of the forefinger and thumb of the right hand. *Rest the little finger* of the right hand upon the board to *steady* the hand. (See Fig. VII, *d.*) *Keep the surface of contact of the thumb and forefinger vertical and also parallel to the line*. (See Fig. VII, *e.*) Raise the cord vertically with the right hand. Sight lengthwise of the line. *If it appears straight when seen from a point directly over it, it will have been raised vertically*. Let go the line. On removing it, a *straight* chalk-mark will be found, on the board, joining the given points.

Second method. If it is more convenient to stand at the *side* of the board, use the left hand, and the eyes, as before. Grasp the line between the right forefinger and thumb, with the right palm down, and with the backs of the fingers to the front. *Keep the surface of contact of the thumb and forefinger vertical and parallel to both straight portions of the line*. Snap the line, as before.

Ex. VII, 4. — *To join two given points of a horizontal board, by a crooked chalk-mark.* Stretch the chalked line between the given points, as in Ex. VII, 3. Carry the line to the left, or to the right, of the vertical while raising it. If it appears, from a point directly over its original position, to be bent at the right thumb and finger, it *has* been carried to the right or left of the vertical. Let go the line. On removing it, a *crooked* chalk-mark will be found upon the board.

Ex. VII, 5. — *To join two given points of a board by aid*

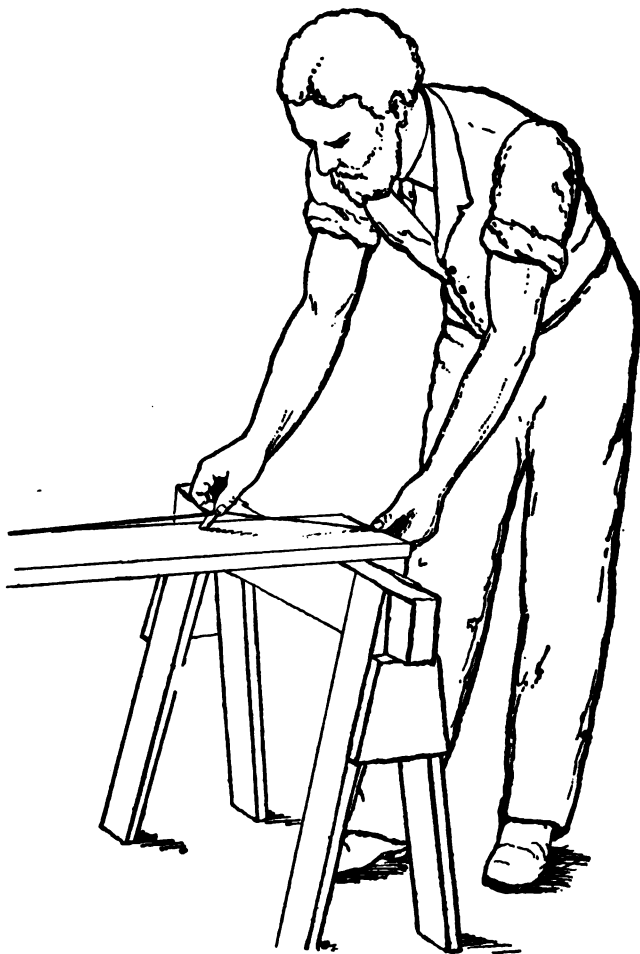

Fig. VII, c.

SNAPPING THE CHALK-LINE. POSITION OF THE BODY.

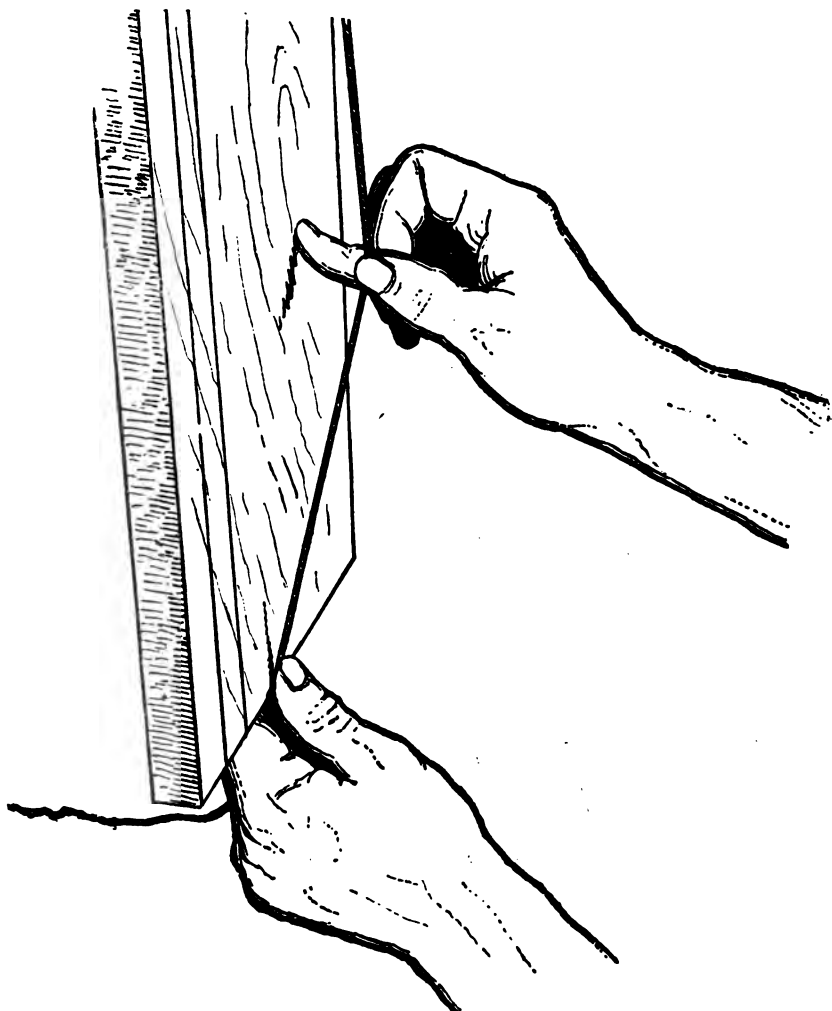

Fig. VII, *d*.

SNAPPING THE CHALK-LINE. POSITION OF THE HANDS.



Fig. VII, *c*.

THE SURFACE OF CONTACT OF THE THUMB AND FOREFINGER,
AS SEEN FROM A POINT IN THE VERTICAL PLANE OF
THE CHALK-LINE.

of a straight or a curved ruler. The ruler should be placed upon the surface of the board, with its *edge* passing *very near* to both of the points, *without covering them*. The edge should be *equally distant* from both points. *Prevent the ruler from slipping* upon the surface of the board by weights, or by some other means. With the right hand place the marking-tool on one of the points, and incline it toward the edge until it rests against it. *With the left hand, press the edge of the ruler, near the point where the marking-tool touches it, firmly down upon the surface of the board.* Mark along the edge of the ruler *without varying the inclination* of the marking-tool, either to the surface of the board, or to the edge of the ruler. Vary the position of the left hand, as often as is necessary, to keep the surface of the ruler in contact with the board near the point where the marking-tool touches it. *Take care that the marking-tool does not follow the grain of the wood,* causing the inclination of the tool to vary, or causing the ruler to slip upon the surface of the board. The result will be a faithful copy of the shape of the edge of the ruler.

Ex. VII, 6. — *To mark, roughly, a line upon a board, parallel to an edge and at a given distance from it.* Clasp the graduated rule firmly with the left hand. Rest the rule upon the board, with its length square with the edge, and with its end at the given distance from it. With the left thumb, press the rule upon the surface of the board; rest the left forefinger against the edge of the board. (See Fig. VII, *f*.) Place the second finger of the right hand upon the board, and against the end of the rule. Let the marking-tool touch the end of the rule, the second finger, and the surface of the board. (See Fig. VII, *f*.) Slide the marking-tool and rule along the surface. The line thus drawn will be nearly parallel to the edge, and nearly at the given distance from it.

Ex. VII, 7. — *To mark a straight line through a given point, at right angles to a tried edge, when the tried edge is*

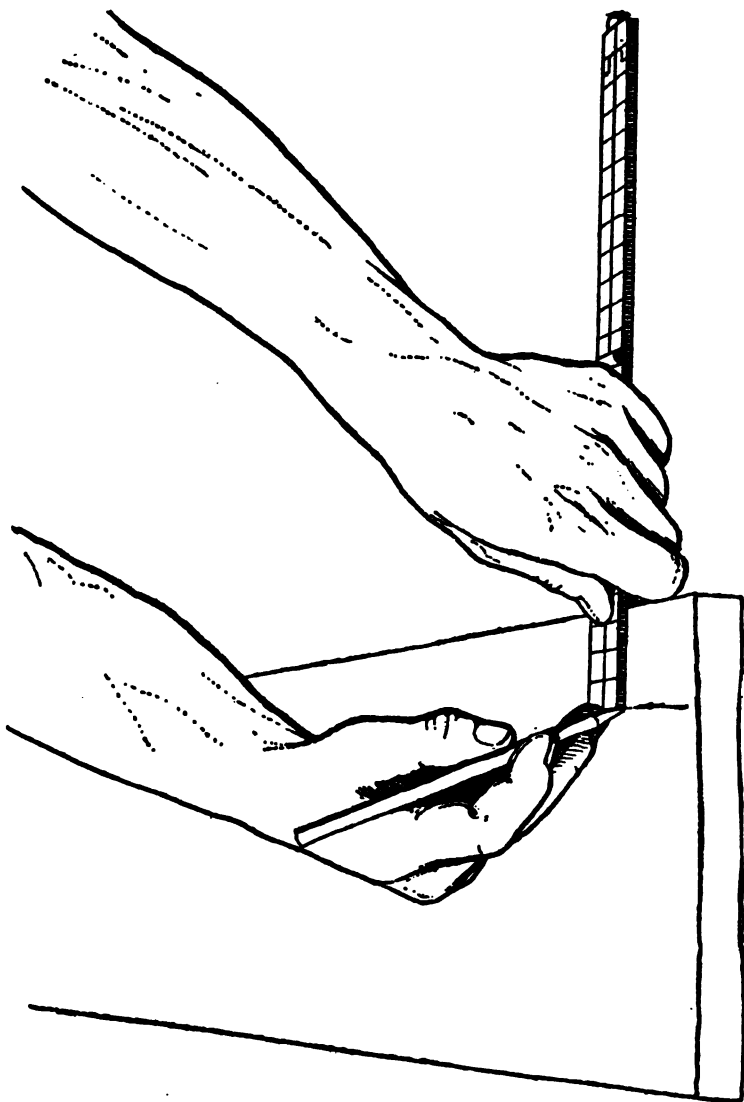
Fig. VII, *f*.

DRAWING A LINE NEARLY PARALLEL TO THE EDGE.

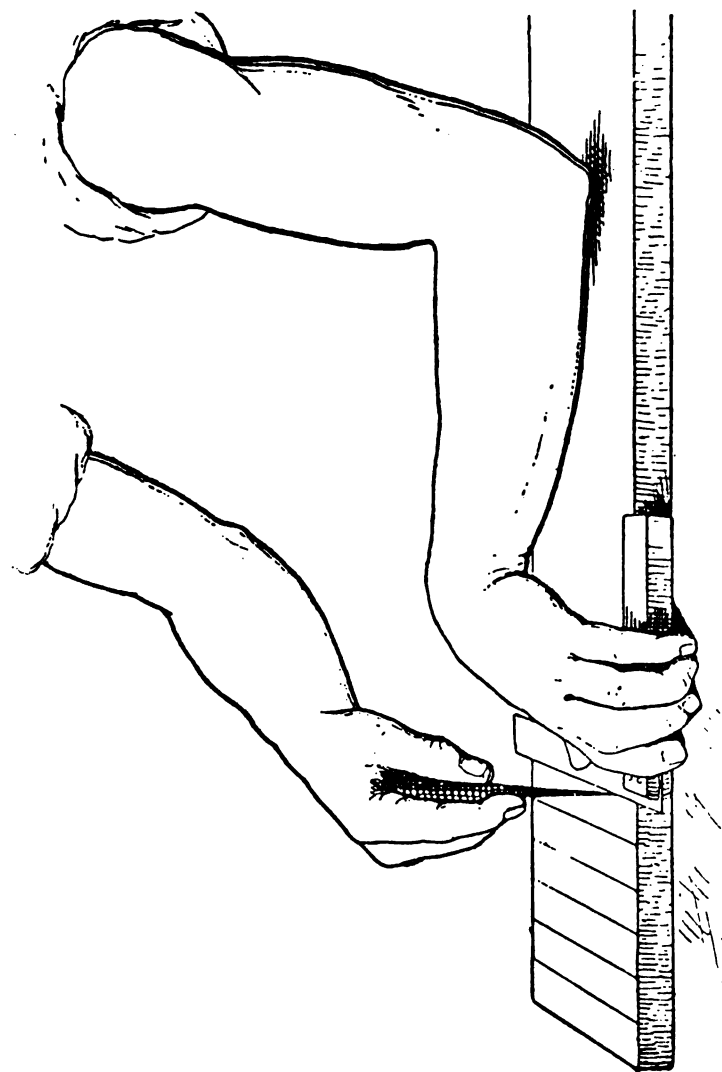

Fig. VII, *g*.

THE LEFT-HAND EDGE IS THE TRIED EDGE.

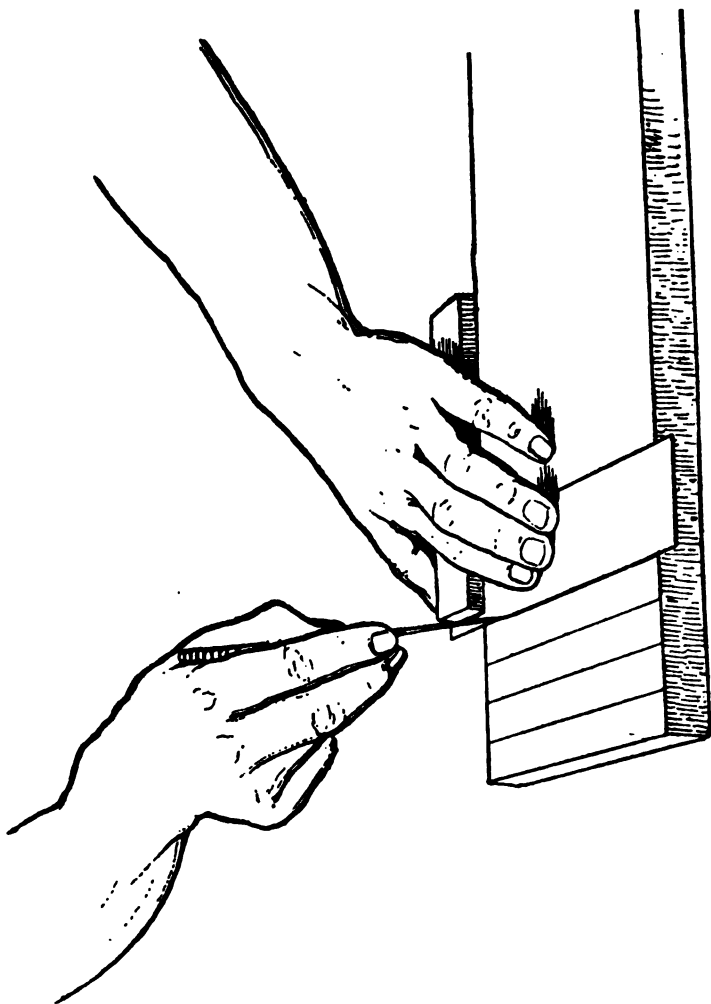

Fig. VII, *k*.

THE RIGHT-HAND EDGE IS THE TRIED EDGE.

the left-hand edge of the board. With the fingers of the left hand, press the beam of the try-square firmly against the tried edge. (See Fig. VII, *g.*) Let the edge of the blade pass very near to the given point without covering it. With the thumb, press the blade of the square firmly upon the surface of the board, changing the position of the thumb, if necessary, as the marking-tool moves along the edge. Place the marking-tool upon the given point, and against the edge of the blade. Mark across the board without changing the inclination of the tool, or permitting the blade to spring off from the surface.

Second method. Place the marking-tool upon the given point, and the square upon the board, with the edge of its blade at a little distance from the tool. Slide the square toward the tool, until the edge of its blade touches the tool. While sliding the square, press its beam against the tried edge. *If the tool is not pushed out of position by the blade,* there is no objection to this method.

Ex. VII, 8. — *To mark a straight line, through a given point, at right angles to a tried edge, when the tried edge is the right-hand edge of the board.* (See Fig. VII, *h.*) Proceed as in Ex. VII, 7, except that the beam of the square is to be pressed against the tried edge with the left *thumb*, and the blade is to be pressed against the surface with the *fingers* of the left hand.

Ex. VII, 9. — *To mark, accurately, upon a block, a line parallel to a tried edge, and at a given distance from it.* Grasp the lower side of the block with the left hand. Grasp the gauge with the right hand, the first finger encircling the head, and the *thumb* pressed against the side of the bar as *nearly opposite the spur as may be.* (Fig. VII, *i.*) Press the head against the tried edge, the further lower corner of the bar resting upon the surface. (Fig. VII, *j.*) Beginning at the nearest point, *push the gauge forward with the thumb,* turning it just enough to make a mark with the spur. The mark must not be too deep.

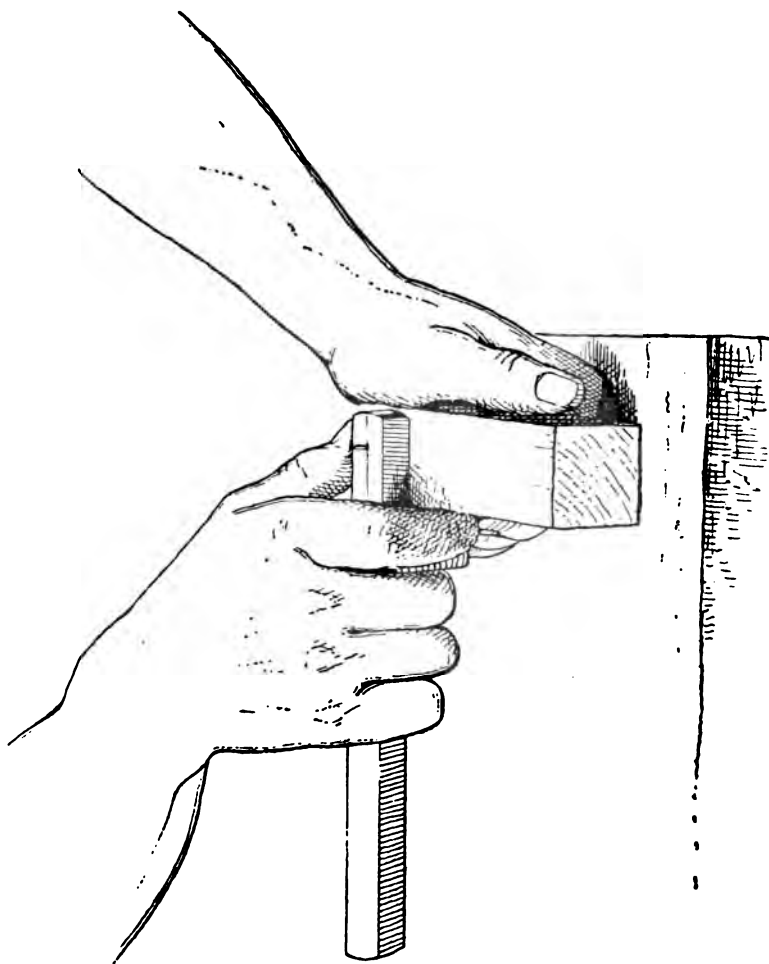

Fig. VII, *i*.

THE THUMB IS OPPOSITE THE SPUR.



Fig. VII, j.

THE FURTHER LOWER CORNER OF THE BAR RESTS UPON THE SURFACE.

CHAPTER VIII.

SCORING AND PARING.

WHEN a specified form is to be "roughed out" of a stick of wood, it is usual to make the *largest chips* that can be removed with safety, in order that the *unnecessary work* of cutting the wood into small chips *may be avoided*. This is so important an art, that, in well conducted wood-carving

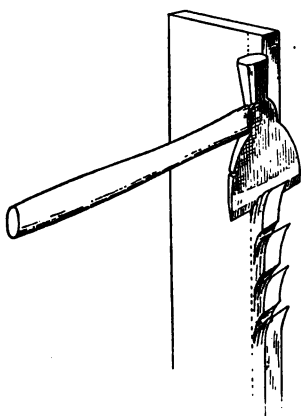

Fig. VIII, a.
SCORING.

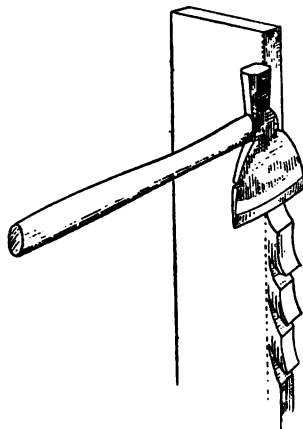

Fig. VIII, b.
PARING.

establishments, *only the most skilful workmen are permitted to rough out work.*

Large chips may be removed by scoring and paring.

EXERCISE VIII, 1. — *To trim to a line, with a hatchet.*
Take a piece of pine board and mark a line upon it about

an inch from one edge. Remove the wood, between the mark and the edge, by scoring and paring. *Score* into the board, as shown in Fig. VIII, *a*, beginning at the end that rests upon the block; then reverse the board, and *pare* off the chips, as shown in Fig. VIII, *b*. *Do not attempt to finish the surface.* The common hatchet is not a finishing tool.

Ex. VIII, 2. — *To make a chamfer, with a knife.* Draw lines, on two of the sides of a pine stick, parallel to one of its long edges. Score into the stick, *nearly* to the lines, then reverse it, and pare or whittle off the chips, as shown in Fig. VIII, *c*.

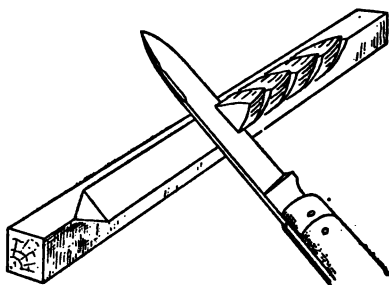

Fig. VIII, *c*.

MAKING A CHAMFER.

Ex. VIII, 3. — *To make chamfers with a carver's chisel.* Draw lines, upon one of the wide, flat surfaces of a block, parallel to its edges. Draw similar lines upon each of the four, adjoining surfaces. Cut, first, the chamfers that *cross* the grain (see Figs. VIII, *d*, VIII, *e*, and VIII, *f*), then the others. *Finish the chamfers*, as you cut away the chips. The carver's chisel *is* a finishing tool.

Ex. VIII, 4. — *To cut to a semi-circular line, with a paring chisel.* Describe, with the dividers, a semi-circle near one end of a pine stick. (See Fig. VIII, *g*.) Pare to the

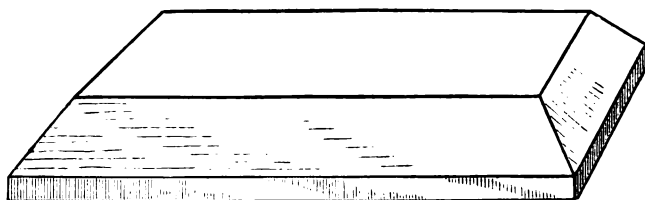

Fig. VIII, *d*.
CHAMFERED BLOCK.

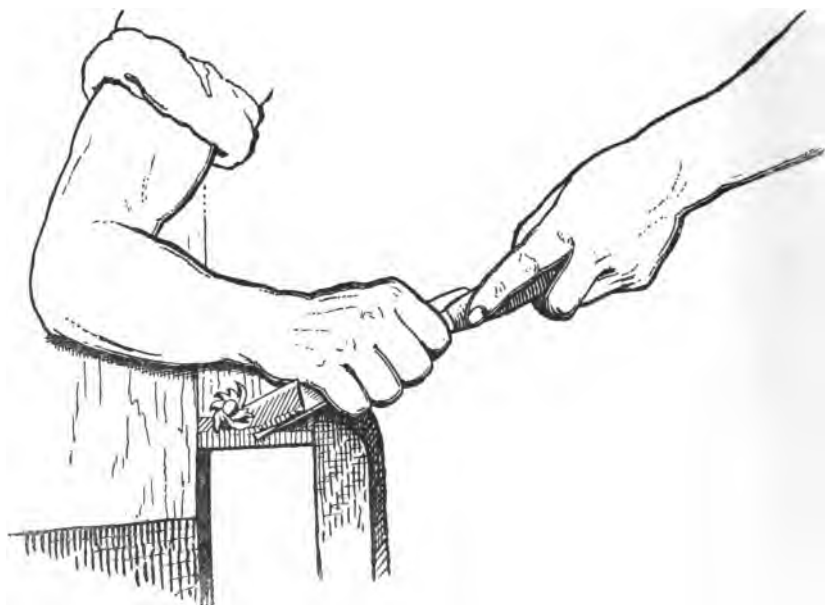

Fig. VIII, *e*.
CUTTING A CHAMFER ACROSS THE GRAIN.

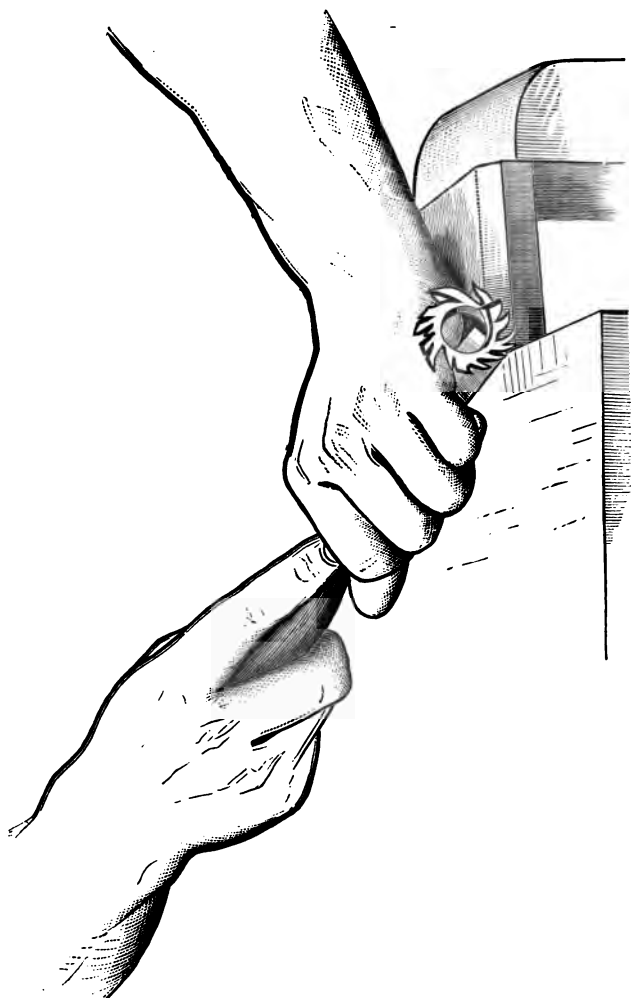

Fig. VIII, *f*.

IF THE CHISEL CUTS TOWARD THE BLOCK, WHEN IT CUTS THE EDGE,
THE EDGE WILL NOT BE SPLINTERED.

line, as shown. The *first* cut should be made a short distance *outside* of the line, and *near one end* of the semi-circle. The chips will then, easily, split out of the way of the chisel. After reaching the *middle* of the semi-circle, begin again at the other end. Finally, finish with light chips, cutting close to the semi-circle.

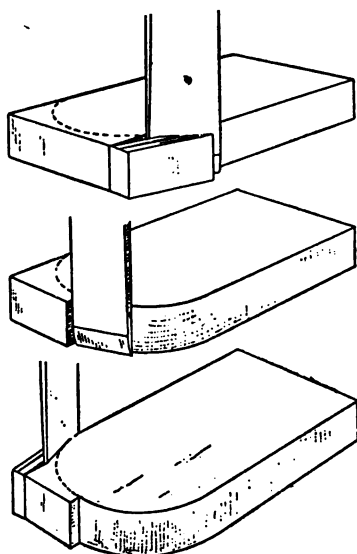

Fig. VIII, g.

PARING.

CHAPTER IX.

S A W I N G.

Caution.—TAKE CARE NOT TO REMOVE ANY PART OF THE GUIDING LINE WITH THE SAW.

EXERCISE IX, 1.—*Cross-cut sawing.* Take a piece of clear pine board, on which lines are drawn square with the tried edge. With the *left hand*, grasp the tried edge in such a place as will bring the thumb-nail, when extended, even with the line farthest to the right, at the same time *pressing down* on the board, *with the palm* of the hand, to hold it firmly in place on the horses. (See Fig. IX, *a.*) Grasp the saw with the right hand, with the forefinger extended along the side of the handle, to assist in steadying the saw, and with the other fingers passed through the opening made for that purpose. That hand will then take, nearly, the position that it has when one is pointing with the forefinger. Place the middle of the cutting-edge of the saw, at the line, on the tried edge of the board, the *blade resting gently* against the *left thumb-nail*. The *left hand points* of the teeth, should *just graze*, but *not cut into*, the line. Hold the blade of the saw, *square* with the surface of the board. *Without bearing on* the saw, draw it several inches toward the shoulder in a straight line. This will *start the kerf*, and will prevent the saw from moving sidewise, and the edge from being *torn and splintered*. With very slight pressure, reverse the motion just completed, and move the saw its full length, back and forth, continually, guiding it by the line drawn. To guide the saw correctly, watch closely its path, from a position vertically above the line. *If the saw leaves the line, twist the blade,*

while it is moving, *in the kerf*. The back edge of the saw is somewhat thinner than the cutting-edge. Then the blade can thus be twisted, and the true line returned to. *Do not press upon the saw*, for if it is pressed upon, it will be more liable to *depart from the line*, and it will *cut less smoothly*. The saw may be *injured* by pressing too hard upon it.

To ascertain if the blade is square with the surface of the

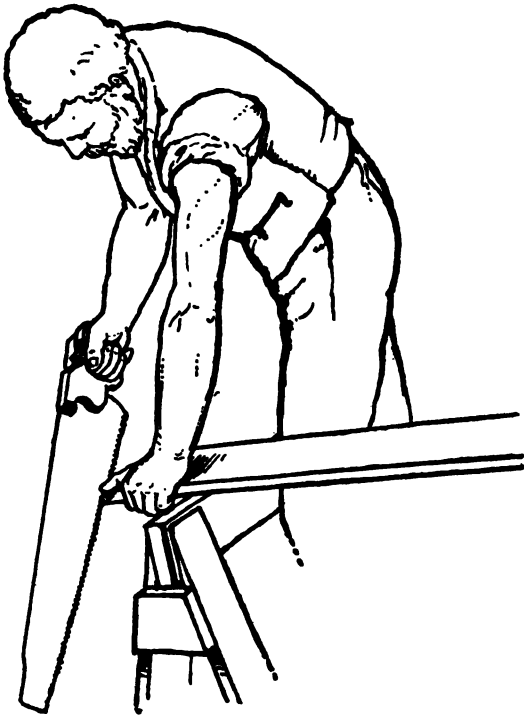

Fig. IX, a.

STARTING THE KERF.

board, grasp the beam of the try-square, with the left hand, with its inside edge next to the palm. Place the outside edge of the beam upon the work, and the outside edge of the tongue against the side of the saw. When the kerf is

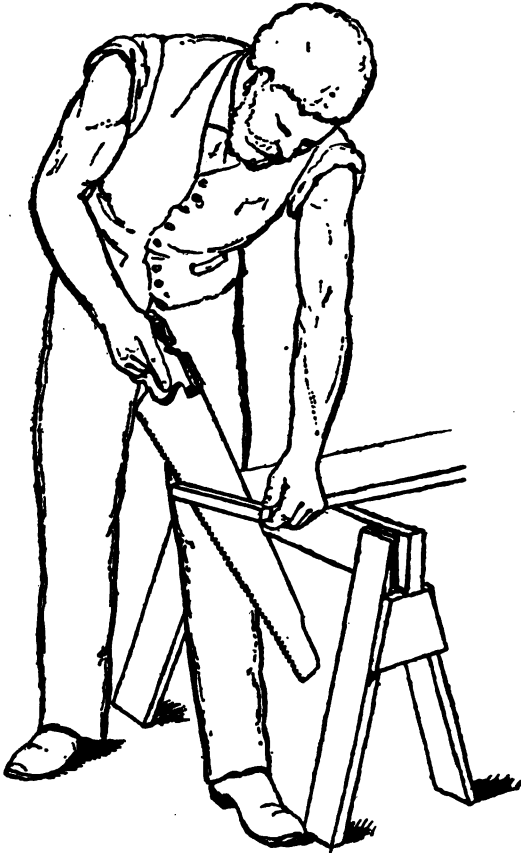

Fig. IX, *b*.

PREVENTING THE PIECE FROM FALLING, AND THE EDGE
FROM SPLINTERING.

square with the surface, the *saw will touch the edge* of the square its *full length*. When the kerf is *not* square with the surface, *bend* the blade of the saw toward the desired position, while it is moving in the kerf, and until the fault is corrected. When the saw is well advanced through the work, place the left knee against the nearest edge of the board, to prevent it from moving. Grasp the board, with the thumb and finger of the left hand, on *both* sides of the kerf, to *support* the piece that is being sawn off. While in this position, the sawing may be completed, without permitting the piece to fall upon the floor. Near the end of the cut, take short, light, quick strokes, to prevent splintering the edge. (Fig. IX, *b*.)

Ex. IX, 2. — *Rip-sawing*. Take a clear pine board, with lines drawn upon it lengthwise. Place it upon the horses, nearly as shown in Fig. IX, *c*, but *let its right-hand edge so far over-hang the horses, that the saw can pass the ends of the horses freely*. The end of the board need not over-hang the side of the first horse, as shown. With the right hand, grasp the saw, as in Ex. IX, 1. Press the right knee upon the board, to hold it in position. With the left hand, grasp the end of the board, and, at first, with the left thumb-nail, guide the blade steadily. *Saw close to the line but do not remove any* of it. Should the parts, on each side of the blade, *draw together and bind it in the kerf*, insert a wedge, in the kerf, in front of the saw. A scratch-awl or a screw-driver is usually at hand and can be used for this purpose. (See Fig. IX, *d*.) Generally, when rip-sawing from the butt of a tree towards the top, the parts *spread*; and when rip-sawing in the opposite direction, from the top toward the butt, the parts *come together and bind* the saw.

The board may be *so narrow*, that it *cannot be held firmly*, if its right-hand edge over-hangs the ends of the horses. In that case, place it upon the horses, as shown in Fig. IX, *c*.

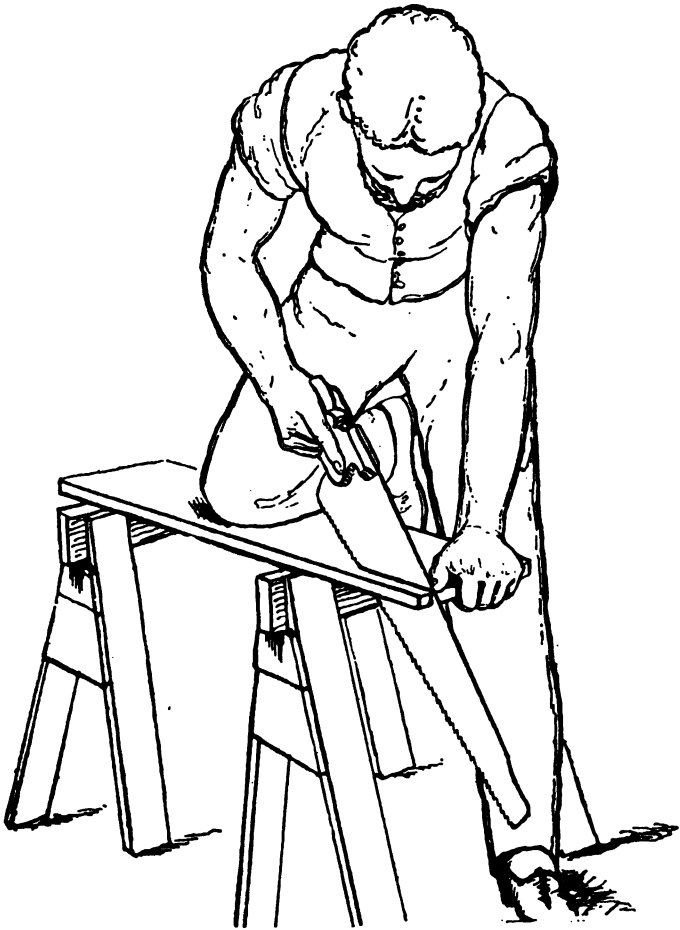

Fig. IX, *c*.

MOVING THE BOARD TO AVOID CUTTING THE HORSE.

Saw along a line, almost to the first horse. Move the board forward and, again, cut toward the horse. After the kerf has been made long enough, move the board backward, rest its end on the horse, and place the saw, in the kerf, behind the horse. (See Fig. IX, *d*.)

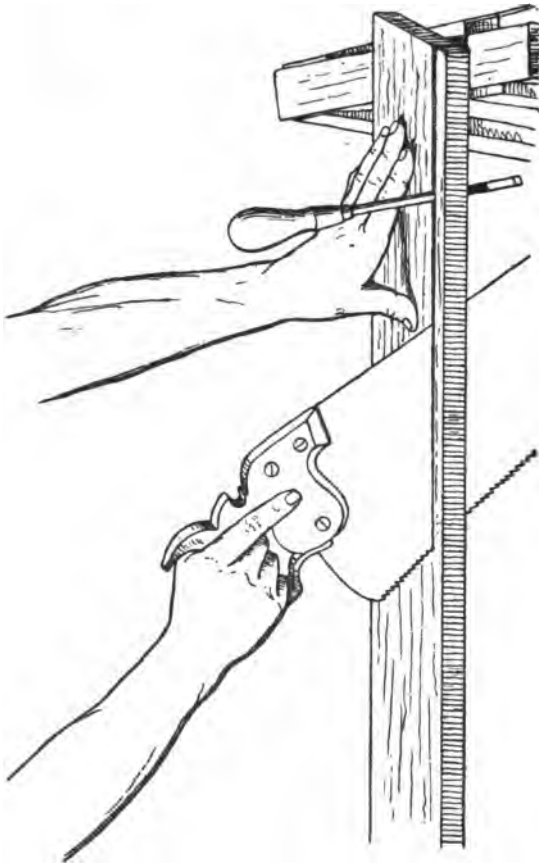

Fig. IX, *d*.

SPREADING THE KERF.

CHAPTER X.

REDUCING WARPED TO PLANED SURFACES.

EXERCISE X, 1. — *To warp a board.* Wet one side and dry the other.

EX. X, 2. — *To produce a plane from a warped surface, using saw, chisel, block-plane, and jack-plane.* Lay a warped board, of even thickness, on the bench, with the hollow side up, and observe that it will rock on the bench. Put *wedges* underneath, to prevent it from rocking. So adjust the wedges, that the *highest corners* of the board will be *equally distant from the bench*. Draw a line, on each end of the board, parallel to the top of the bench, and touching the *lowest* part of the upper edge. About three-fourths of an inch from each end, make a cut with a cross-cut saw, from the top of the board downward. Let it end in a line, *parallel with the surface of the bench*, but not quite so near to that surface as the line drawn across the end. Remove, with a chisel and block-plane, all of the wood lying between each saw-cut and the *nearest* end, thus producing a surface nearly or quite parallel to the bench, and containing the line drawn upon the end, as shown in Fig. X, *b*. Take two straight-edged sticks of equal width, about twenty or thirty inches long, having *one thin or feather edge*. These sticks are called "winders." Place one of them in each notch, with the thin edge uppermost. *Sight* across them, as in Fig. X, *c*. *If the thin edges are found to be in line, the surfaces upon which the winders rest are in the same plane;* if the thin edges are not in line, one or both of those surfaces must be *cut away*, until they *do* come into the same

plane. Join the edges of the surfaces thus formed, by straight lines drawn on each of the *long* sides of the board. Remove all of the wood that lies *above* the plane surface containing these lines. The result is the desired plane sur-

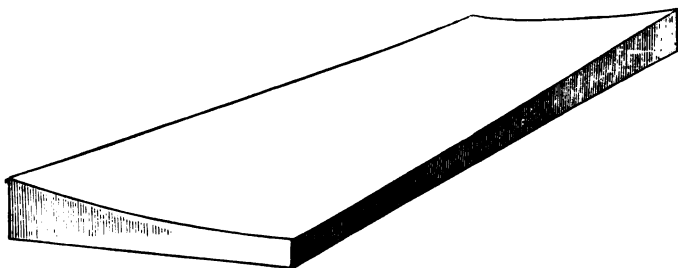

Fig. X, *a*.

UPPER SURFACE WARPED.

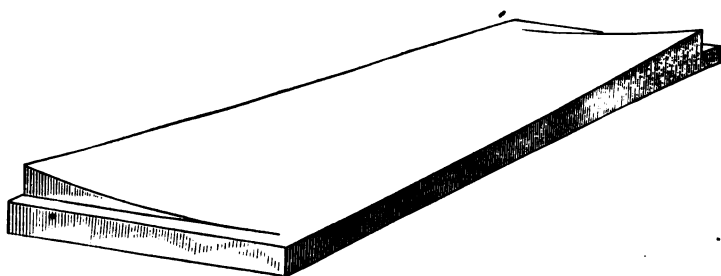

Fig. X, *b*.

SURFACES AT ENDS PARALLEL TO BENCH.

face. The saw, the chisel, and the plane, may all be used in removing the superfluous wood. Test the surface, occasionally, with a straight-edge, placed crosswise of the board.

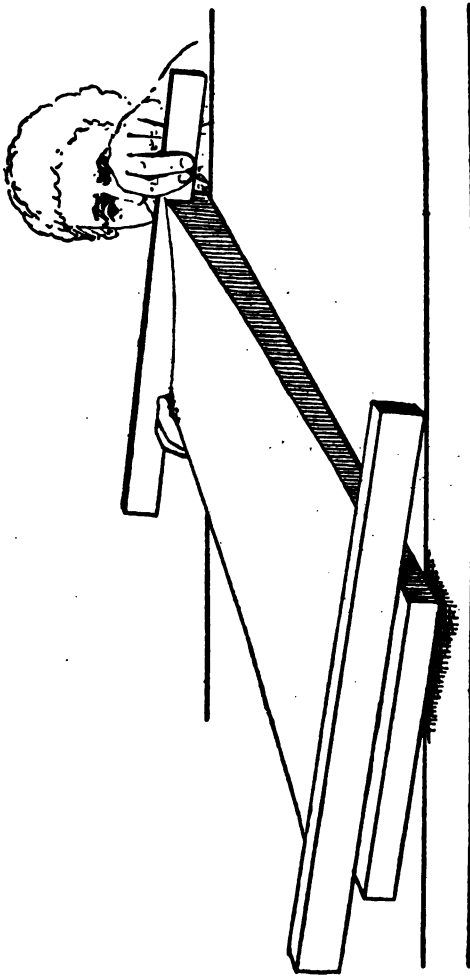

Fig. X, c. — TESTING WITH WINDERS.

CHAPTER XI.

PRODUCING PLANE SURFACES THAT ARE SQUARE WITH EACH OTHER.

EXERCISE XI, 1. — Make a number of blocks from clear pine boards. The edges are to be square with, or parallel with, one another. The side-faces are to be smooth-planed, the edge-faces are to be jointed, and the ends are to be block-planed.

Ex. XI, 1. — Make a number of blocks from clear pine plank. The edges are to be square with, or parallel with, one another. The sides are to be jointed, and the ends are to be block-planed.

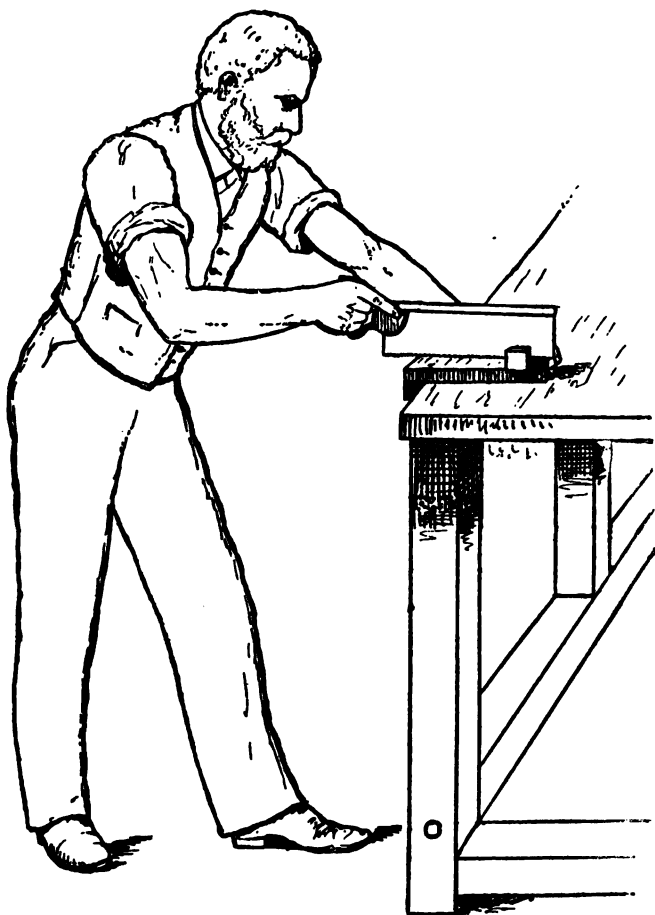

Fig. XI, a.

THE USE OF THE BACK-SAW AND THE BENCH-HOOK.

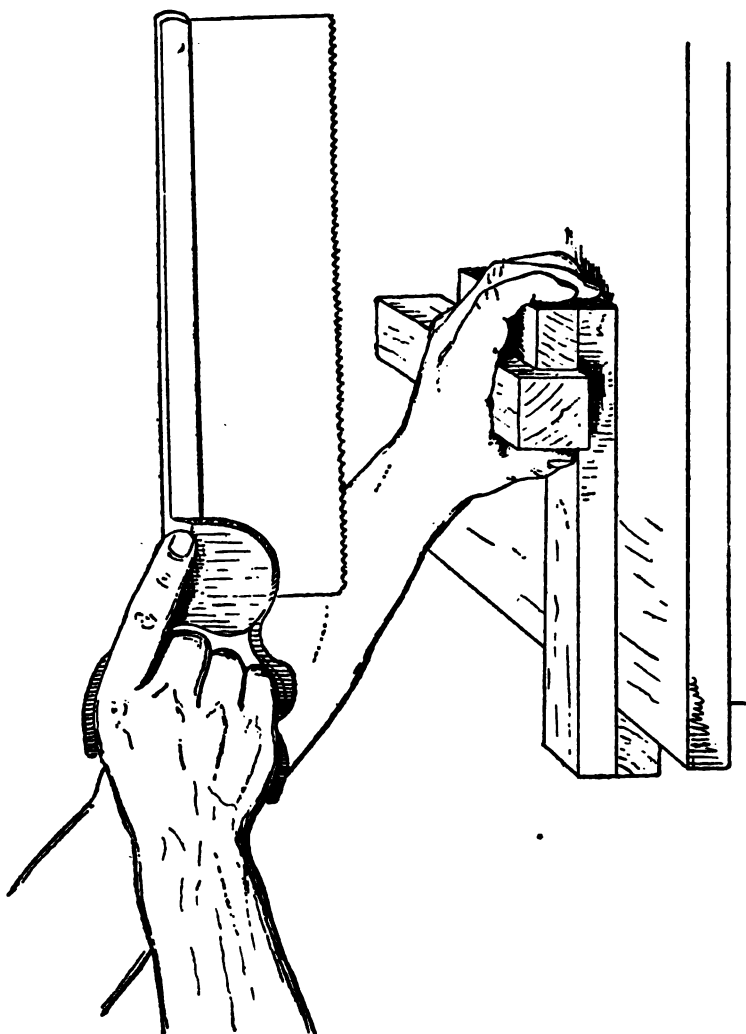

Fig. XI, &

THE USE OF THE BACK-SAW AND THE BENCH-HOOK.

CHAPTER XII.

BORING.

EXERCISE XII, 1.— *To bore, across the grain, partly through a block.* Bore a number of holes in a pine block, in regular succession. (See Fig. XII, a.) Let the centres of the holes be in the same line and *so near to one another that the wood will break out between the holes.* Bore to within about

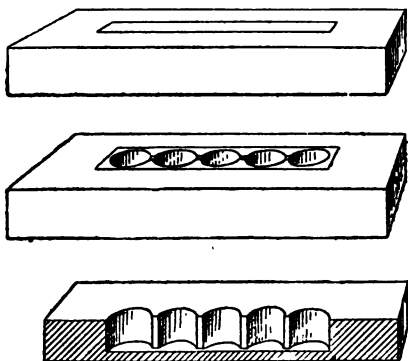

Fig. XII, a.

BORING, ACROSS THE GRAIN, PARTLY THROUGH.

a quarter of an inch of the under side of the block. Make several lines of holes in this way. Let the centre lines of the holes be *square with the upper surface.*

Ex. XII, 2.— *To bore, across the grain, entirely through a block.* (See Fig. XII, b.) Bore holes, as in Ex. XII, 1, but let the *point* of the bit go entirely through. Then *turn the block over*, and bore from the other side.

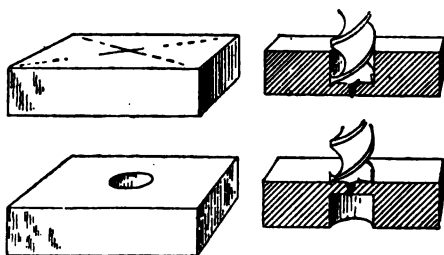

Fig. XII, b.

BORING, ACROSS THE GRAIN, ENTIRELY THROUGH.

Ex. XII, 3. — *To bore, across the grain, through a block, and entirely from one side.* Bore a number of holes *entirely* through a pine block, as in Ex. XII, 2, but, instead of turning the block over, in order to bore from the under side, *clamp the block upon the top of another*, by means of a hand-screw or of a vise, and *bore entirely through from one side.*

Ex. XII, 4. — *To bore, lengthwise of the grain, beginning at the ends, and meeting in the centre.* Take a sufficiently thick piece of clear pine, and find the *centre of each end* by drawing diagonal lines upon it. Bore, *with the grain*, along the centre line, half the length of the block. *Turn the stick end for end*, and bore until the holes meet in the centre.

Ex. XII, 5. — *To bore lengthwise of the grain entirely through from one end.* Take a sufficiently thick piece of clear pine. Find the centre of each end. Draw the centre lines, of *two of the long adjoining sides*. Bore with the grain along the centre line entirely through the block *from end to end*. Occasionally, sight lengthwise of the bit, to see if it is parallel with the long centre lines.

Ex. XII, 6. — *To sharpen the bit.*

CHAPTER XIII.

JOINERY.

SOME of the surfaces of finished joints are more conspicuous and important than the rest. This is true of those surfaces of the joined parts of a picture-frame, which can be seen when the picture is viewed. In such cases, *the appearance of the work is improved, if pains are taken to select for those more conspicuous positions the best surfaces of the sticks, to be joined.* Conspicuous surfaces of one stick, are often intended to be flush with conspicuous surfaces of the other stick, to which it is to be joined. These may be called the *flush surfaces.* All of the lines that are drawn, in laying out the work, should have their positions fixed with reference to these flush surfaces. Frequently, *one piece is used as a measure or pattern, for determining the dimensions of the parts of the other piece that are to fit it.*

Any stick that is to be used in the following exercises, should have its edges made either parallel to or square with one another, before beginning the exercise. The *first step* to be taken in *any* of the exercises is to select and mark each of the flush surfaces with an X. Whenever it is desirable to prevent the work from slipping about, hold it against the wooden bench-hook, fasten it in the vise, or fasten it upon the bench with a wooden hand-screw. When cutting cross-grained wood with a chisel, *cut diagonally across the grain, in such direction that no splits shall extend into the stick, but all into the chips.*

Halving Together.

EXERCISE XIII, 1. — *To halve together two sticks, at their ends.* (See Fig. XIII, a.) Mark one stick A and the other B. *To mark the flush surfaces.* Notice that, as is indicated by the sketch of the finished joint, the top of A is to be flush with the top of B; a long side of A is to be flush with an end of B; and an end of A is to be flush with a long side of B. Select, and mark with an X, the surfaces of A and of B, that will make the handsomest and best flush surfaces.

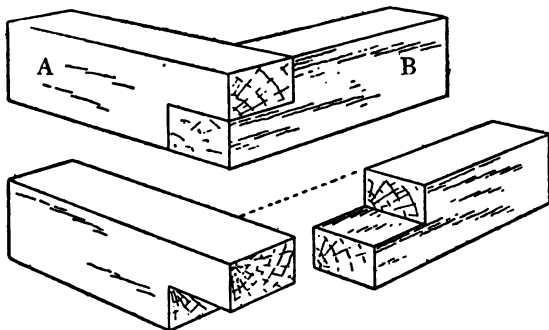

Fig. XIII, a.

A HALVED-TOGETHER JOINT.

To line out the work. Place the try-square upon B, with its beam touching the long, vertical, marked surface, with its tongue upon the top, and with its edge a little less than the width of A from the marked end of B. Place A, right side up, upon the top of B, with one long, lower edge, touching the edge of the square, and with its marked end flush with the marked, vertical side of B. Slide A and the try-square, together, along the top of B, until the marked, vertical side of A, becomes flush with the marked end of B. Remove A, and,

with a sharp knife, line across B, at the edge of the square. Extend this line half-way down each of the long, vertical sides of B. Draw similar lines upon the lower side, and the long, vertical sides, of A, using the upper side of B as a measure, and turning the tops of both pieces downward, in order that the lines may be easily drawn. Set the spur of the gauge at a distance from the head equal to half of the common height of the sticks. *Guide the head of the gauge by the upper surfaces of A and B*, in turn, and gauge along both of the long vertical sides of each, from the vertical lines previously drawn to the marked ends. Gauge also across the marked ends. Place each stick, in turn, in the mitre-box, or in the vise, or against the bench-hook. Saw across each, with a sharp, fine-toothed back-saw, close to the knife-marks, and down to the gauge-marks. *Take care not to remove, with the saw, any portion of either of the knife-marks or of the gauge-marks.*

To remove, from A and B, in turn, the wood between the saw-cut and the plane of the three gauge-marks. — First method. Place each stick, in turn, on one side, upon a board on the bench, and fasten it with a wooden hand-screw. With a paring-chisel, that is wider than the cut to be made, split or pare off several chips, parallel to the grain. *Incline the chisel*, so that the chips shall grow thinner as the tool cuts deeper. *Incline it so much that the chips shall not split beneath the plane of the three gauge-marks.* Let the last cut coincide with the upper gauge-mark. Turn the other side of the stick uppermost and repeat the operation. This will leave a *ridge*, running lengthwise of the stick. Its lower lines will coincide with *two* of the gauge-marks. With the wide chisel, pare away the outer end of the ridge. Let the last cut coincide with the gauge-mark at the end. Turn the stick half-way over, bringing the ridge uppermost, and fasten it again with the hand-screw. With a narrow paring-

chisel, bevel away the inner end of the ridge to terminate in a straight line joining the corners where the knife-marks and the gauge-marks meet. *Split away*, with the chisel, *nearly* all of the pyramidal ridge remaining. *Pare* off the rest, and, occasionally, test the surface produced, with a straight edge of the chisel.

To remove, from A and B, in turn, the wood between the saw-cut and the plane of the three gauge-marks.—Second method. Place each stick, in turn, upright in the vise. With a sharp, medium-fine-toothed ripping-saw, cut along the gauge-marks, nearly to the cut made by the back-saw. Finally, pare the surfaces, as when using the first method, or, *pare the wider surface, with a small plane that is made for the purpose.*

To remove, from A and B, in turn, the wood between the saw-cut and the plane of the three gauge-marks.—Third method. Place each stick, in turn, upright in the vise. With a sharp, fine-toothed ripping-saw, cut, *very accurately*, close to the gauge-marks, nearly to the cut made by the back-saw. *Take care not to cut away any portion of the gauge-marks, and not to saw beyond the knife-marks.* Square out the corner with a narrow paring-chisel.

When both sticks have been treated by *either* method, as has been directed, they will fit together as shown in Fig. XIII, *a*.

Mortising.

Ex. XIII, 2. — *To make an open, mortise-and-tenon joint.* (See Fig. XIII, *b*.) Select, and mark with an X, each of the flush surfaces. Mark that stick which is to contain the mortise, A, and the other, B.

To line out the work. Mark the length of the mortise in A, by laying the try-square, and B, upon it. (See Ex. XIII, 1.) Mark a point, in *each edge of the top* of A, at the

edge of the blade of the square, with a sharp knife. Rest the beam of the square upon the top of A, and, with the edge of the blade at each of the points, in turn, make *fine* knife-marks, *on the sides* of A, where the *end* of the mortise will be. These knife-marks *should not extend entirely across* the sides of A, but they should be a *little* longer than the *thickness* of the mortise. Obtain the length of the *tenon* of B, by laying the try-square, and A, upon it. Line across the top of B with a sharp knife. Rest the beam of the

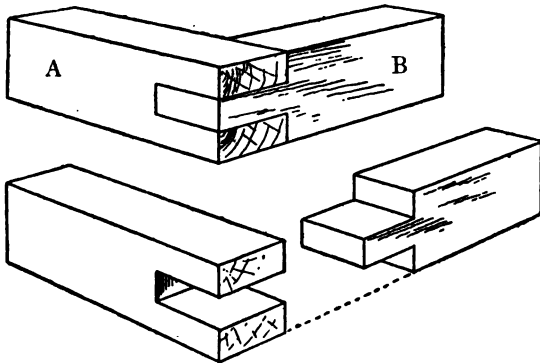

Fig. XIII, b.

AN OPEN MORTISE-AND-TENON JOINT.

square upon the top of B, and carry lines down both sides through the ends of the line upon the top. Join the lower ends of these lines, by a straight knife-mark across the bottom, thus *lining entirely around the stick*. Set the spur of the gauge at a distance from the head of the gauge equal to about *one-third* of the thickness of either piece. Rest the head of the gauge upon the *top* of both pieces, in turn, and gauge along the sides, *as far as the cross-lines* previously drawn. Gauge, also, across the flush ends of both pieces.

Then set the spur at a distance from the head equal to about *two-thirds* of the thickness of either piece, and gauge along the sides and across the ends, of both pieces, near the other gauge-lines.

To remove the superfluous wood from the tenon. Notice that the shape of that part of the stick, which is to be removed from either side of the tenon, is like that which was removed from the sticks that were halved together in Ex. XIII, 1. Remove, then, the superfluous wood, by either method of that exercise.

To remove the chief part of the superfluous wood from the mortise. — First method. Place A upon a board, upon the bench, with one of its *sides* uppermost, and fasten it there with a wooden hand-screw. Take a *mortising-chisel* which is, about an eighth of an inch, *narrower* than the thickness of the mortise. Rest its cutting-edge upon the wood to be removed, at about *a quarter of an inch from the flush end*, and with its centre upon the centre of the thickness of the mortise. Hold the *straight face of the chisel* upright, and next to the flush end. *Take care not to tip the chisel sidewise.* Drive the chisel in with a mallet. The *bevelled side* of the chisel will cause the chisel and the chips to *work out through the open end* of the mortise. Take each succeeding cut nearer to the blind end of the mortise, the last one beginning at about one-eighth of an inch from that end. *Do not cut closer to the blind end than one-eighth of an inch.* Turn the stick the other side over. Fasten it, again, with the hand-screw. Cut, as before, from the side now uppermost, beginning the last cut from this side at about one-eighth of an inch from the blind end. Next, *turn the chisel* around so that the *bevelled face* is next to the *flush end*. Hold the chisel vertical and trim nearly to the end of the mortise.

To remove the chief part of the superfluous wood from the mortise. — Second method. Place the stick upright in the

wise, and, with a *medium-fine-toothed saw*, saw just within the gauge-marks, on both sides, nearly to the blind end of the mortise. *Take care not to remove any part of the gauge-marks or of the knife-marks, with the saw.* — With a sharp, narrow *mortising-chisel*, remove the wood that is between the saw-cuts.

To remove the chief part of the superfluous wood from the mortise. — Third method. With a *bit*, of a diameter that is a little less than the thickness of the mortise, bore a number of holes, in regular succession, entirely through the mortise, as in Ex. XII, 2, or Ex. XII, 3. Begin near the open end of the mortise.

To remove the chief part of the superfluous wood from the mortise. — Fourth method. With a *bit*, of a diameter that is a little less than the thickness of the mortise, bore a single hole, entirely through the mortise, near its blind end. Make *two saw-cuts*, as in the second method.

To finish the mortise, having removed the chief part of the superfluous wood, by either one of the four methods. With a *paring-chisel*, of the same width as the mortising-chisel, *square out the blind end* and *bevel the sides* to terminate in a straight line joining the corners where the knife-marks and the gauge-marks meet. Then, with a *wide paring-chisel*, bevel the *sides* and the *outer edge* of the mortise until the bevels terminate in the gauge-marks. Then split and pare, to the planes of the gauge-marks, as in Ex. XIII, 1.

To remove the superfluous wood from the mortise. — Fifth method. Place the stick, upright, in the vise, and, with a sharp, fine-toothed back-saw, saw, *very accurately, close to the gauge-marks*, just within them, on both sides of the mortise, and near to its blind end. *Take care not to remove any part, of the gauge-marks, or of the knife-marks.* With a sharp, narrow mortising-chisel, remove the chief part of the wood that is between the saw-cuts. With a *sharp, narrow paring-*

chisel, that is a *little narrower* than the thickness of the mortise, square out the blind end of the mortise, to the lines.

Ex. XIII, 3. — *To make an open, double, mortise-and-tenon joint.* (See Fig. XIII, c.) Make the thickness of each mortise and tenon about *one-fifth* of the thickness of the sticks. Proceed otherwise, as in Ex. XIII, 2.

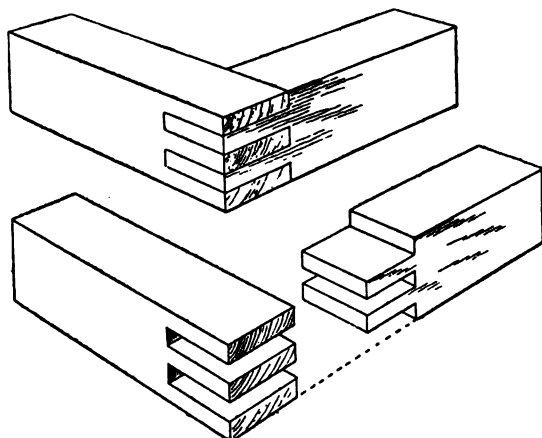

Fig. XIII, c.

AN OPEN, DOUBLE, MORTISE-AND-TENON JOINT.

Ex. XIII, 4. — *To make a mortise-and-tenon joint.* (See Fig. XIII, d.) Select, and mark with an X, each of the flush surfaces. Mark the stick that is to contain the mortise, A, and the other, B.

To line out the work. — Lay the stick, A, upon the bench, with its top uppermost. Place the blade of the try-square upon the top of A, in such position that its *edge* shall be *directly over* the intended position of one end of the mortise. With a sharp knife, mark a point in each edge of the top, at the edge of the blade. Without changing the position of the

edge of the blade, rest B upon A, with its top uppermost, with its flush end flush with the flush side of A, and with one of its lower edges touching the edge of the blade. Mark a point, in each edge of the top of A, at the lower edge of B, and over the intended position of the *other* end of the mor-

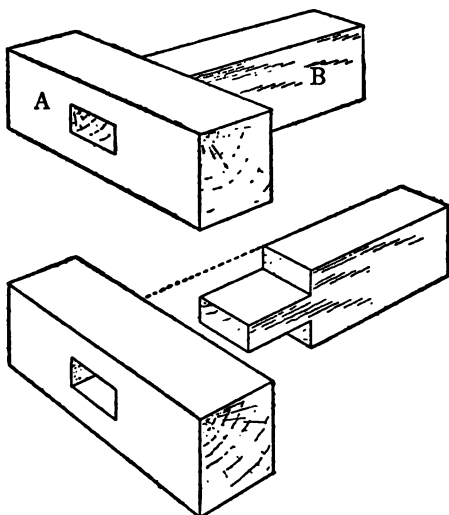

Fig. XIII, d.

A MORTISE-AND-TENON JOINT.

tise. Square down from each of the four marked points, in the top of A, and make four knife-marks, of the proper length, upon the sides of A, where the ends of the mortise will come. Find the length of the tenon of B, and line entirely around, at the inner end of the tenon, as in Ex. XIII, 2. Gauge the sides of the mortise and tenon, as in Ex. XIII, 2.

To remove the chief part of the superfluous wood from the mortise. — First method. Bore a number of holes, entirely through the block, in regular succession, as in Ex. XII, 2, or as in Ex. XII, 3.

To remove the chief part of the superfluous wood from the mortise. — Second method. With a sharp, mortising-chisel, that is a little narrower than the end of the mortise, cut deep and across the grain, at about one-eighth of an inch from one end of the mortise. Hold the chisel upright, and with its straight face toward the *nearer end* of the mortise. On withdrawing the chisel a *gap* is left in the wood, as in Ex. III, 4. Carry the chisel a short distance toward the farther end of the mortise, and cut again into the wood. The bevelled edge of the tool will cause both the tool and the chip to work out into the gap. Repeat this process until the gap has been sufficiently enlarged. Then turn the piece the other side up, and meet the first gap by a similar one from the other side. Next, proceed to finish the mortise, as in Ex. XIII, 2.

To remove the superfluous part of the wood from the mortise. — Third method. Bore one hole entirely through the wood and near the end of the mortise. Pass a narrow saw-blade, (such as a gig, fret, or key-hole saw-blade,) through the hole, and saw out the superfluous wood along both sides, and across the further end, of the mortise. Whichever method is used to remove the chief part of the wood, finish with two paring chisels. One should be a little narrower than the sides, and the other a little narrower than the ends, of the mortise. First, with the *narrower* chisel of the two, square out the *ends* of the mortise, to the knife-marks, and bevel the sides, to terminate in straight lines joining the corners of the ends. Then, with the *wider* chisel, bevel the *sides*, to the gauge-marks. Finally, split away the ridge and pare to the plane of the gauge-marks, with the wider chisel; testing the accuracy of the work with a straight edge of the chisel.

Ex. XIII, 5.— *To make a blind, mortise-and-tenon joint.*
(See Fig. XIII, *e.*)

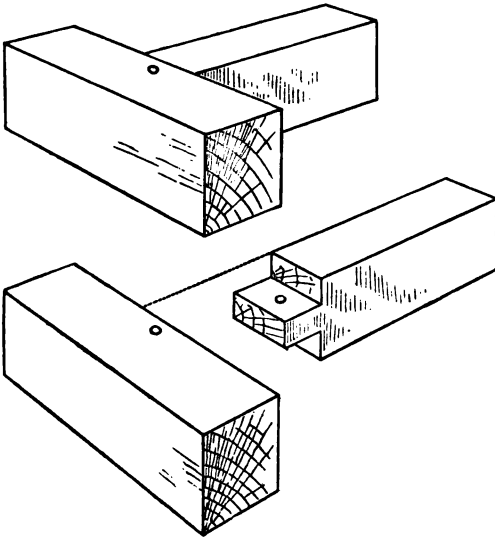

Fig. XIII, *e.*

A BLIND MORTISE-AND-TENON JOINT.

Ex. XIII, 6. — *To make a blind, mortise-and-tenon joint, at the end of a brace.* (See Fig. XIII, f.)

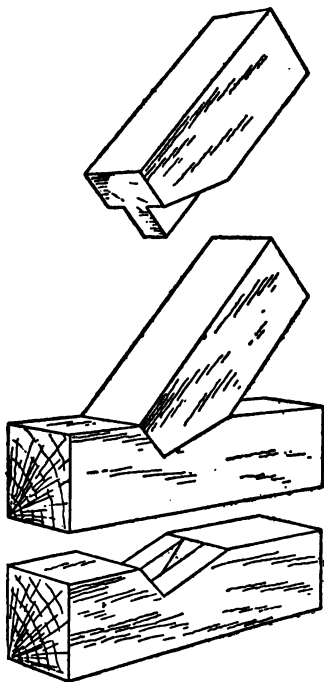

Fig. XIII, f.

A BLIND MORTISE-AND-TENON JOINT, AT THE END OF A BRACE.

Mitreing.

Ex. XIII, 7. — *To make a mitre joint, without the aid of a mitre-box.* (See Fig. XIII, g.) Mark one stick A and the other B. Select, and mark with an X, each of the flush sides.

To line out the work. Make a knife-mark, in the *upper edge* of the *inner side* of A, at a distance from its flush end equal to the exact width of B. Extend this knife-mark, square across the inner side of A, to its lower edge. With the edge of the try-square blade, and the knife, make straight marks running diagonally across the top and bottom of the stick, and joining the top and bottom of the knife-mark on

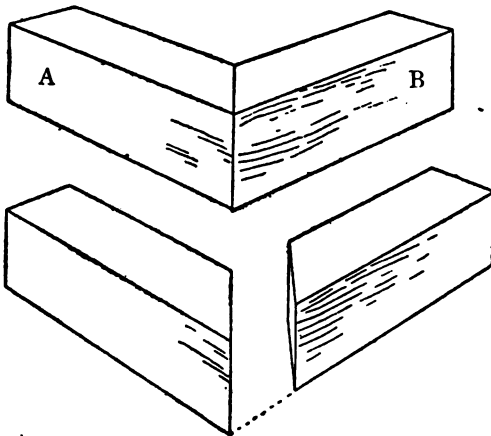

Fig. XIII, g.

A MITRE JOINT.

its inner side, with the top and bottom of the flush end of its flush side. Mark similar lines on B, by a similar process.

To remove the superfluous wood.—*First method.* With a sharp, *medium-fine-toothed* back-saw, saw *nearly* to the lines; then, with a chisel or a plane, pare to the line.

To remove the superfluous wood. — Second method. With a sharp, fine-toothed back-saw, saw to the lines on A and B. The pieces will fit together.

Ex. XIII, 8. — *To make a mitre-box.*

Ex. XIII, 9. — *To make a mitre joint with the aid of a mitre-box.* (See Fig. XIII, g.) Select, and mark with an X, each of the flush surfaces. Without lining out the work, place each piece, in turn, in the mitre-box, in such a position that the diagonal saw-cut, when made, will not shorten the flush side of the stick, but will coincide with the flush end of that side. For exact work, use a sharp, fine-toothed back-saw. If the diagonal kerf of the mitre-box is accurately placed, and if both of the sticks are of the same width, the sticks will fit together as intended.

There is a metallic substitute for the wooden mitre-box, that is much more accurate and convenient for use. It is used in the same manner as the wooden box.

Ex. XIII, 10. — *To make a mitre joint by the aid of a bevel-square.*

Ex. XIII, 11. — *To make a mitre joint with an open mortise-and-tenon.* (See Fig. XIII, h.) Mark the stick that is to contain the mortise, A, and the other, B. Select and mark each of the flush surfaces.

To line out the work. Line out the mitre, as in Ex. XIII, 7. Line out the open mortise and tenon, as in Ex. XIII, 2, except that the only marks to be made upon B, for the tenon, are those on its inside and on its flush end.

To remove the superfluous wood from the mortise, use either of the methods of Ex. XIII, 2.

To remove the superfluous wood from the tenon. With a sharp, fine-toothed back-saw, saw, close to the diagonal lines, along the knife-marks on the inner side, and, along the edge where the flush end meets the flush side, nearly to the tenon. Then proceed by either method of Ex. XIII, 2.

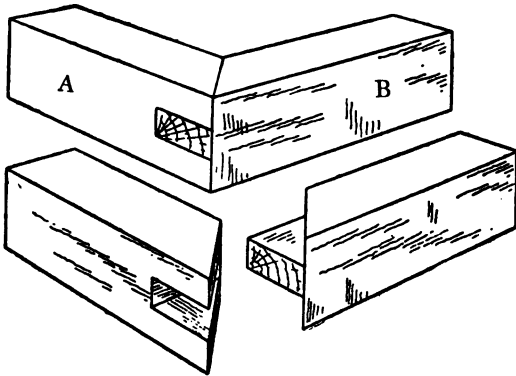

Fig. XIII, *h*.

A MITRE JOINT, WITH AN OPEN MORTISE-AND-TENON.

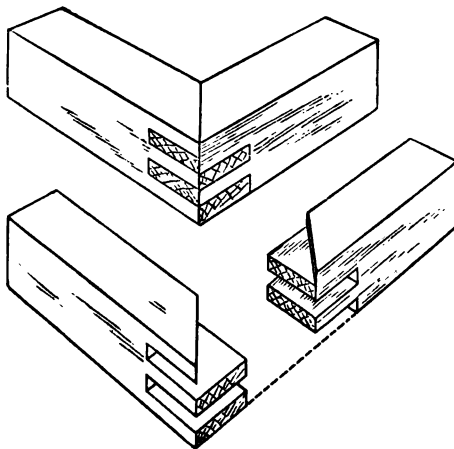

Fig. XIII, *i*.

A MITRE JOINT WITH AN OPEN DOUBLE MORTISE-AND-TENON.

Ex. XIII, 12.— *To make a mitre joint with an open, double mortise-and-tenon.* (See Fig. XIII, i.) Proceed partly as in Ex. XIII, 3, and partly as in Ex. XIII, 9, 10, or 11.

Ex. XIII, 13.— *To make a mitre joint, to be fastened with glued tongues.* (See Fig. XIII, j.)

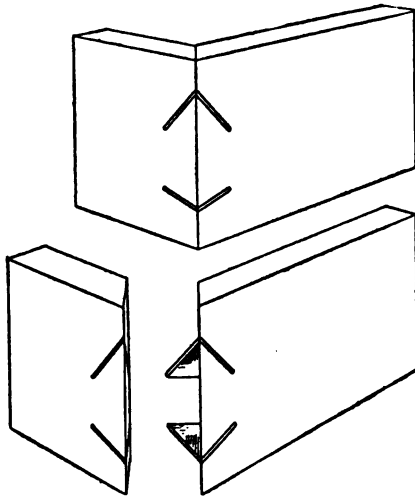

Fig. XIII, j.

A MITRE JOINT, FASTENED BY GLUED TONGUES.

Dowelling.

Ex. XIII, 14. — *To make a dowel joint.* (See Fig. XIII, *k.*)

Ex. XIII, 15. — *To make a half-blind, dowel joint.* (See Fig. XIII, *l.*) Mark the *best* piece, A, and the other, B. Select and mark the flush surfaces. Line across the inner, wide surface of A, at a distance from the end equal to the *thickness* of B, and, with the try-square and knife, continue the line across the edge-faces. Gauge across the end of A, at one-fourth of its thickness from its flush face, and continue the lines, along the narrow sides, as far as the first lines drawn. Remove the parts thus marked out, and hold the end of B, firmly, in the rebate thus formed, using the vise to keep it in position. With a quarter-inch bit, if seven-eighths inch board is used, bore three holes, through the end of B, extending about one inch into the end of A, and located as shown in Fig. XIII, *l.* Into these holes drive tightly-fitting dowel-pins. These pins, if *glued in place*, will firmly unite the two pieces.

Ex. XIII, 16. — *To make a blind, dowel joint.* (See Fig. XIII, *m.*)

Ex. XIII, 17. — *To make a blind, dowel joint, with a mitre.* (See Fig. XIII, *n.*)

Ex. XIII, 18. — *To make a blind, dowel joint, with a post.* (See Fig. XIII, *o.*)

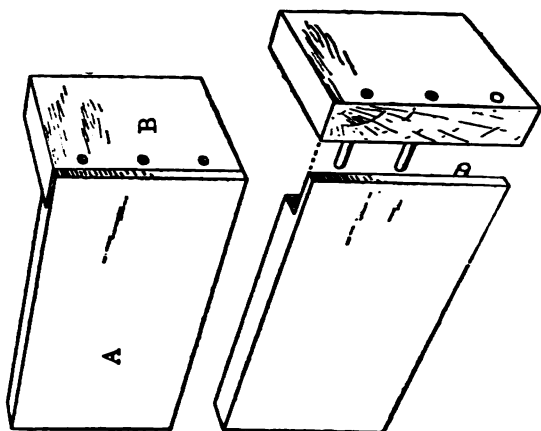
Fig. XIII, *l*.

A HALF-BLIND DOWEL JOINT.

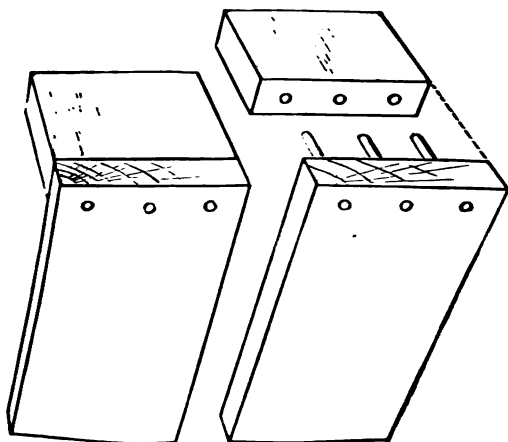
Fig. XIII, *r*.

A DOWEL JOINT.

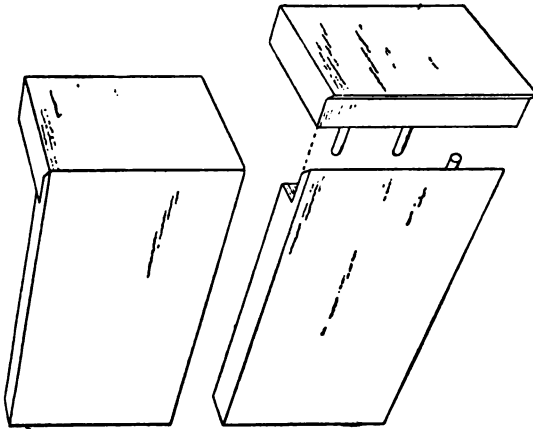

Fig. XIII, n.

A BLIND DOWEL JOINT WITH A MITRE.

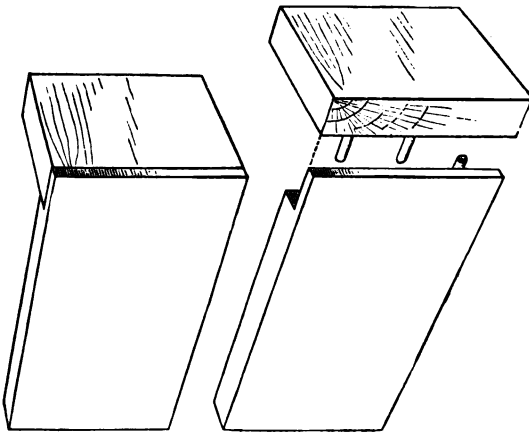
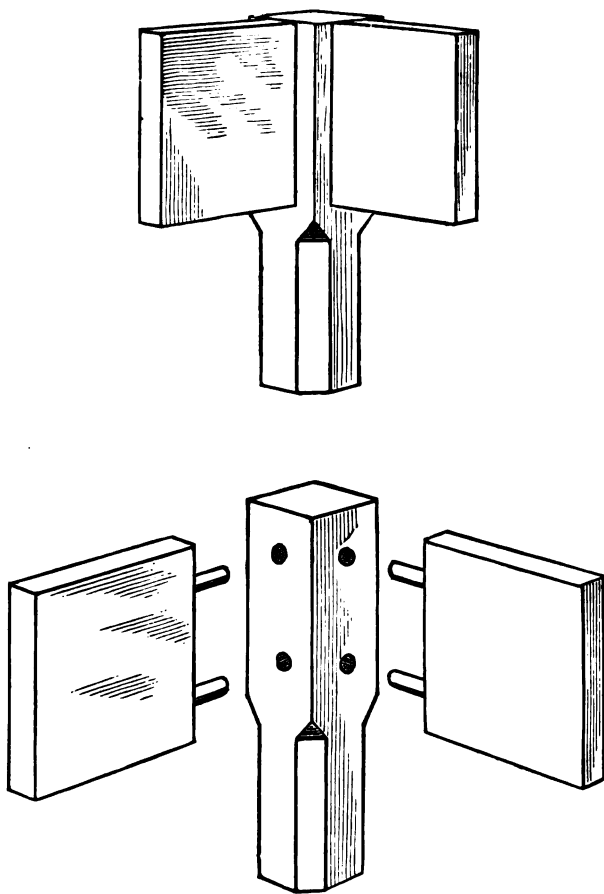

Fig. XIII, m.

A BLIND DOWEL JOINT.

Fig. XIII, *e*.

A BLIND DOWEL JOINT, WITH A POST.

Dovetailing.

Ex. XIII, 19. — *To make a half-dovetail joint, halved together.* (See Fig. XIII, *p.*)

Ex. XIII, 20. — *To make a half-dovetail joint, halved together at a corner.* (See Fig. XIII, *q.*)

Ex. XIII, 21. — *To make a dovetail joint with a single tongue.* (See Fig. XIII, *r.*)

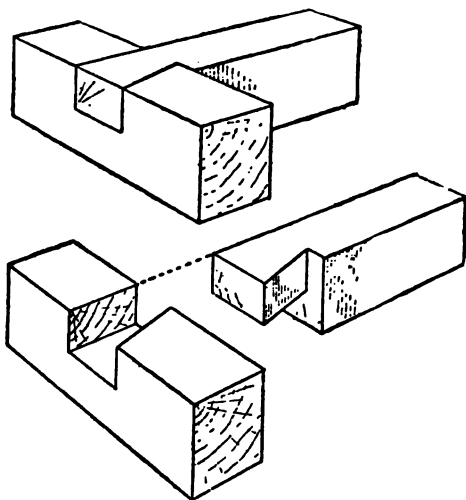

Fig. XIII, *p.*

A HALF-DOVETAIL JOINT, HALVED TOGETHER.

Ex. XIII, 22. — *To make a dovetail joint with several tongues.* (See Fig. XIII, *s.*)

Ex. XIII, 23. — *To make a half-blind dovetail joint.* (See Fig. XIII, *t.*)

Ex. XIII, 24. — *To make a dovetail joint with a mitre.* (See Fig. XIII, *u.*)

Ex. XIII, 25. — *To make a blind dovetail joint.*
(See Fig. XIII, v.)

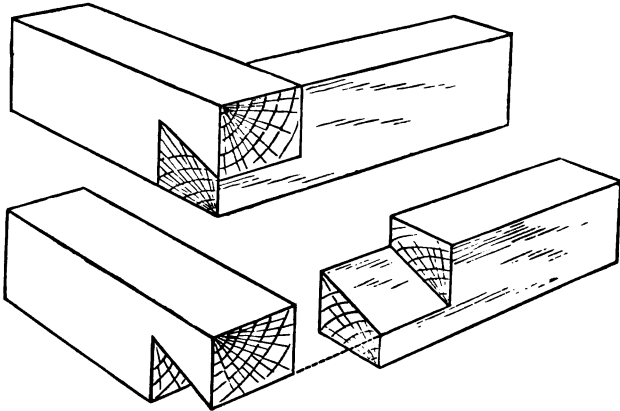

Fig. XIII, q.

A HALF-DOVETAIL JOINT, HALVED TOGETHER AT A CORNER.

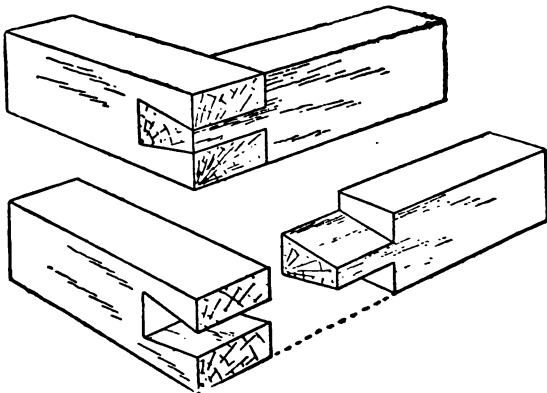

Fig. XIII, r.

A DOVETAIL JOINT WITH A SINGLE TONGUE.

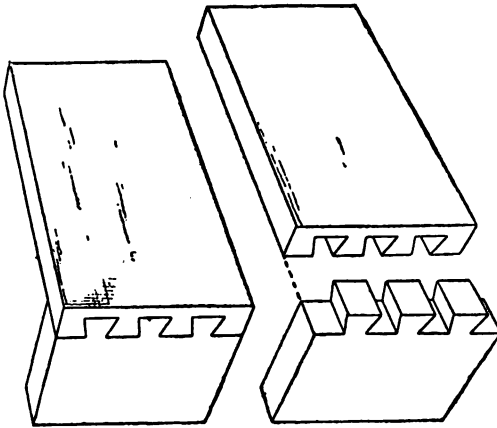

Fig. XIII, t.

A HALF-BLIND DOVETAIL JOINT.

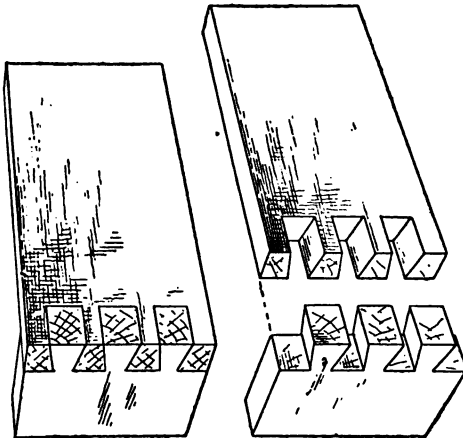

Fig. XIII, s.

A DOVETAIL JOINT WITH SEVERAL TONGUES.

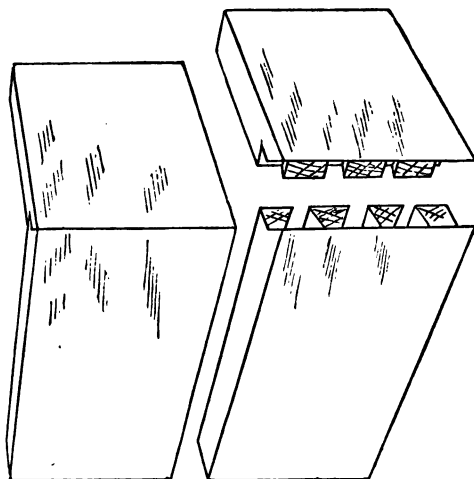

Fig. XIII, v.
A BLIND DOVETAIL JOINT.

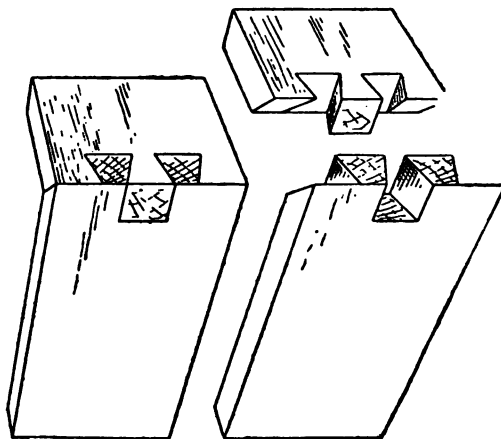

Fig. XIII, w.
A DOVETAIL JOINT WITH A MITRE.

Pinning.

Ex. XIII, 26. — *To fasten the parts of an open mortise-and-tenon joint with a wooden pin.*

Wedging.

Ex. XIII, 27. — *To fasten the parts of a mortise-and-tenon joint with wooden wedges.*

Gluing.

Ex. XIII, 28. — *To fasten the parts of a halved-together joint with hot glue.*

Nailing.

Ex. XIII, 29. — *To fasten the parts of a box with nails.*

Joining with Screws.

Ex. XIII, 30. — *To fasten the parts of a box with screws.*

CHAPTER XIV.

FINISHING.

EXERCISE XIV, 1. — *To finish with sand-paper when the wood is to be painted.*

Ex. XIV, 2. — *To finish with sand-paper when the wood is not to be painted, but varnished.*

Ex. XIV, 3. — *To cleanse the sand-papered surface, if it becomes accidentally soiled.*

Pattern-makers, wood-turners, and some other workers in wood, use still other finishing processes, the nature of which will be apparent from Ex. XIV, 4-6.

Ex. XIV, 4. — *To raise the grain.*

Ex. XIV, 5. — *To fill the grain.*

Ex. XIV, 6. — *To finish with oil, shellac, and alcohol.*

Persons who put on inside finish in houses, cabinet-makers and most workers in wood, leave such processes as are used in the last three exercises for painters to perform.

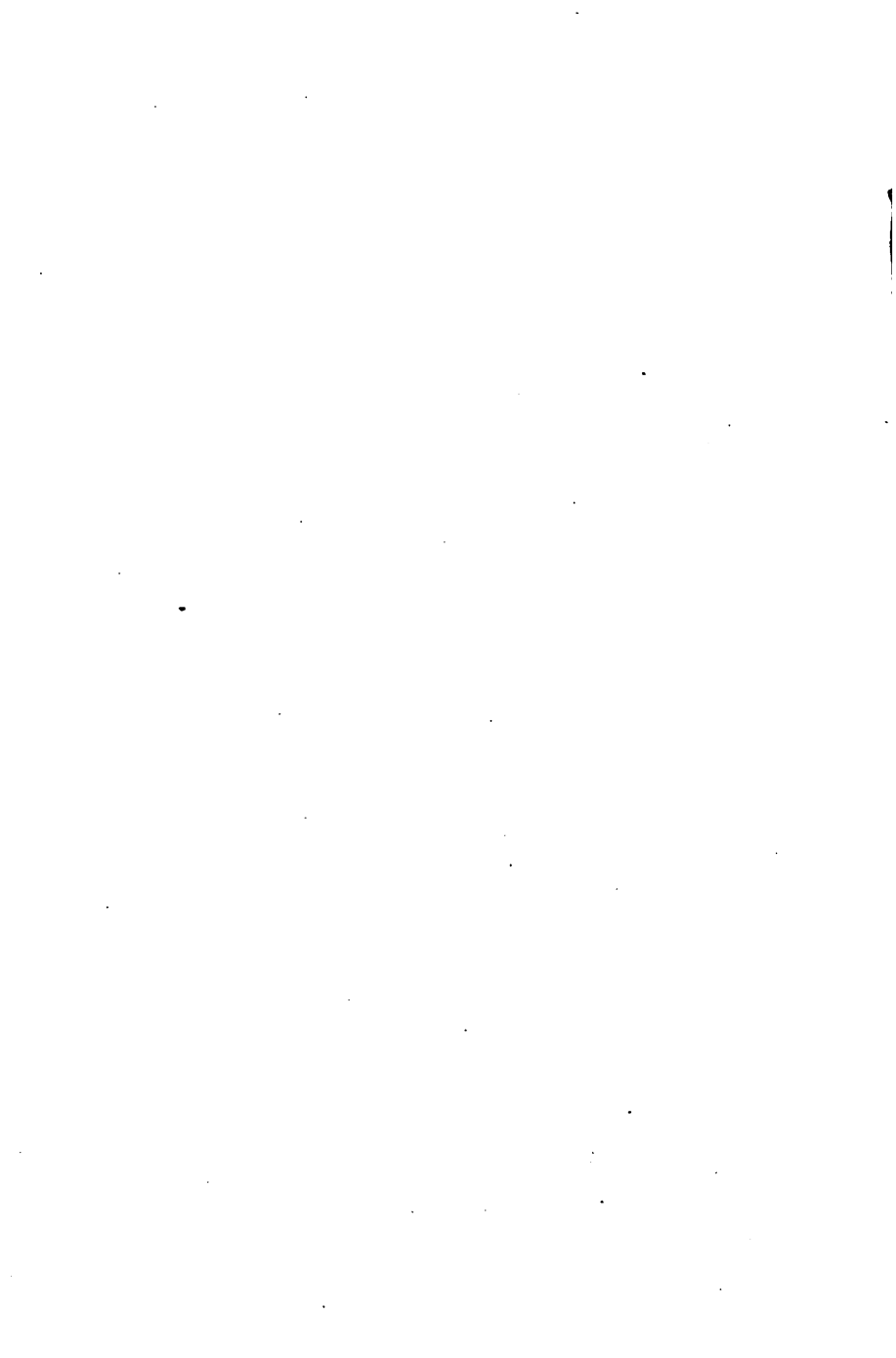

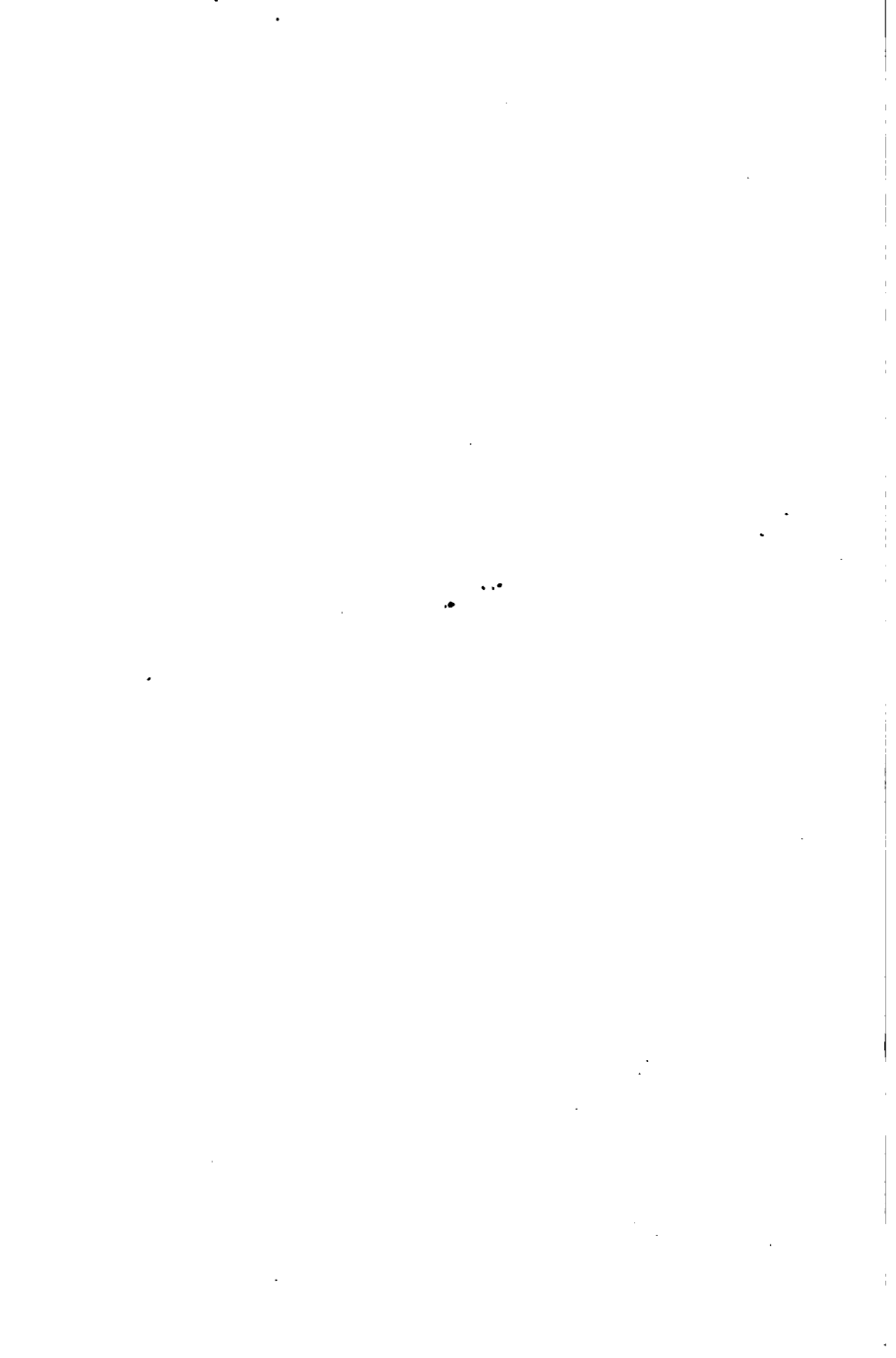

TRA-VAM 16 1920

DUE APR 15 1922

DUE OCT 2 1924

DUE OCT 24 1924

